

3M-Matic™

200a

Type 19000

**Adjustable
Case Sealer**

with

AccuGlide™ II

Taping Heads

**Important
Safeguards**

Turn to page three
for operating
safety information.

Important

It is recommended you
immediately order the
spare parts listed on
page 32. These parts
are expected to wear
through normal use,
and should be kept on
hand to minimize
production delays.

Replacement Parts and Service Information

To Our Customers:

This is the 3M-Matic™/AccuGlide™/Scotch™ brand equipment you ordered. It has been set up and tested in the factory with "Scotch" brand tapes. If technical assistance or replacement parts are needed, call or Fax the appropriate number listed below.

Included with each machine is an Instructions and Parts List manual.

Technical Assistance:

3M-Matic™ Helpline – 1-800/328 1390. Please provide the customer support coordinator with the machine number, machine type/model and serial number. If you have a technical question that does not require an immediate response, you may Fax it to 715/381 0248.

Replacement Parts and Additional Manuals

Order parts by part number, part description and quantity required. Also, when ordering parts and/or additional manuals, include machine name, number and type. A parts order form is provided at the back of this manual.

3M/Tape Dispenser Parts

241 Venture Drive

Amery, WI 54001-1325

1-800/344 9883

FAX# 715/268 8153

Minimum billing on parts orders will be \$25.00. Replacement part prices available on request.

\$10.00 restocking charge per invoice on returned parts.

Note : Outside the U.S., contact the local 3M subsidiary for parts ordering information.



3M Packaging Systems Division

**3M Center, Building 220-8W-01
St. Paul, MN 55144-1000**

3M-Matic, *AccuGlide* and *Scotch* are trademarks of 3M, St. Paul, Minnesota 55144-1000

Printed in U.S.A.

© 3M 1999 44-0009-1851-4(E79.0)

Instruction Manual
 200a Adjustable Case Sealer
 Type 19000

Table of Content	Page
Equipment Warranty and Limited Remedy	1
Description	2
Important Safeguards	3 - 6
Specifications	7 - 9
Set-Up Procedure	10 - 17
Receiving and Handling	11
Lower Outboard Tape Roll Mount, Alternate	11 - 12
Conveyor Bed Height	11 - 12
Tape Loading	13 - 15
Electrical Connection	16
Box Size Set-Up & Operation	16 - 17
Adjustments	19 - 22
Tape Web Alignment	19
Tape Drum Friction Brake	19
Applying Mechanism Spring	20
One-way Tension Roller Assembly	20
Box Drive Belt Tension	21 - 22
Tape Application Leg Length	23
Maintenance	24 - 26
Blade Replacement	24
Replacing Box Drive Belts	24
Cleaning of the Machine	25
Cut-Off Blade	25
Electrical Schematic	25
Circuit Breaker	25
Lubrication	26
Blade Oiler Pad	26
Special Set-Up Procedure	27 - 28
Changing Tape Leg Length	27 - 28
Troubleshooting	29 - 31
Troubleshooting Guide	29 - 31
Suggested Spare Parts	32
How To Order Replacement Parts	32
Repair Service	32
Options/Accessories	33
Replacement Parts Illustrations & Parts Lists	34 - 70
Taping Head Assemblies	34 - 48
Frame Assemblies	50 - 70

Equipment Warranty and Limited Remedy: THE FOLLOWING WARRANTY IS MADE IN LIEU OF ALL OTHER WARRANTIES, EXPRESS OF IMPLIED, INCLUDING, BUT NOT LIMITED TO, THE IMPLIED WARRANTY OF MERCHANTABILITY, THE IMPLIED WARRANTY OF FITNESS FOR A PARTICULAR PURPOSE AND ANY IMPLIED WARRANTY ARISING OUT OF A COURSE OF DEALING, A CUSTOM OR USAGE OF TRADE:

3M sells its 3M-Matic™ 200a Adjustable Case Sealer, Type 19000 with the following warranties:

1. The Taping Head knife blades, springs, and rollers will be free from all defects for ninety (90) days after delivery.
2. All other Taping Head parts will be free from all defects for three (3) years after delivery.
3. The gearmotor will be free from all defects for one (1) year after delivery.
4. All other parts will be free from all defects for ninety (90) days after delivery.

If any part is proved to be defective within its warranty period, then the exclusive remedy and 3M's and seller's sole obligation shall be, at 3M's option, to repair or replace the part, provided the defective part is returned immediately to 3M's factory or an authorized service station designated by 3M. A part will be presumed to have become defective after its warranty period unless the part is received or 3M is notified of the problem no later than five (5) calendar days after the warranty period. If 3M is unable to repair or replace the part within a reasonable time, then 3M, at its option, will replace the equipment or refund the purchase price. 3M shall have no obligation to provide or pay for the labor required to install the repaired or replacement part. 3M shall have no obligation to repair or replace (1) those parts failing due to operator misuse, carelessness, or due to any accidental cause other than equipment failure, or (2) parts failing due to non-lubrication, inadequate cleaning, improper operating environment, improper utilities, or operator error.

Limitation of Liability: 3M and seller shall not be liable for direct, indirect, special, incidental or consequential damages based upon breach of warranty, breach of contract, negligence, strict liability or any other legal theory.

The foregoing Equipment Warranty and Limited Remedy and Limitation of Liability may be changed only by a written agreement signed by authorized officers of 3M and seller.

"AccuGlide", "Scotch", and "3M-Matic" are Trademarks of 3M, St. Paul, Minnesota 55144-1000

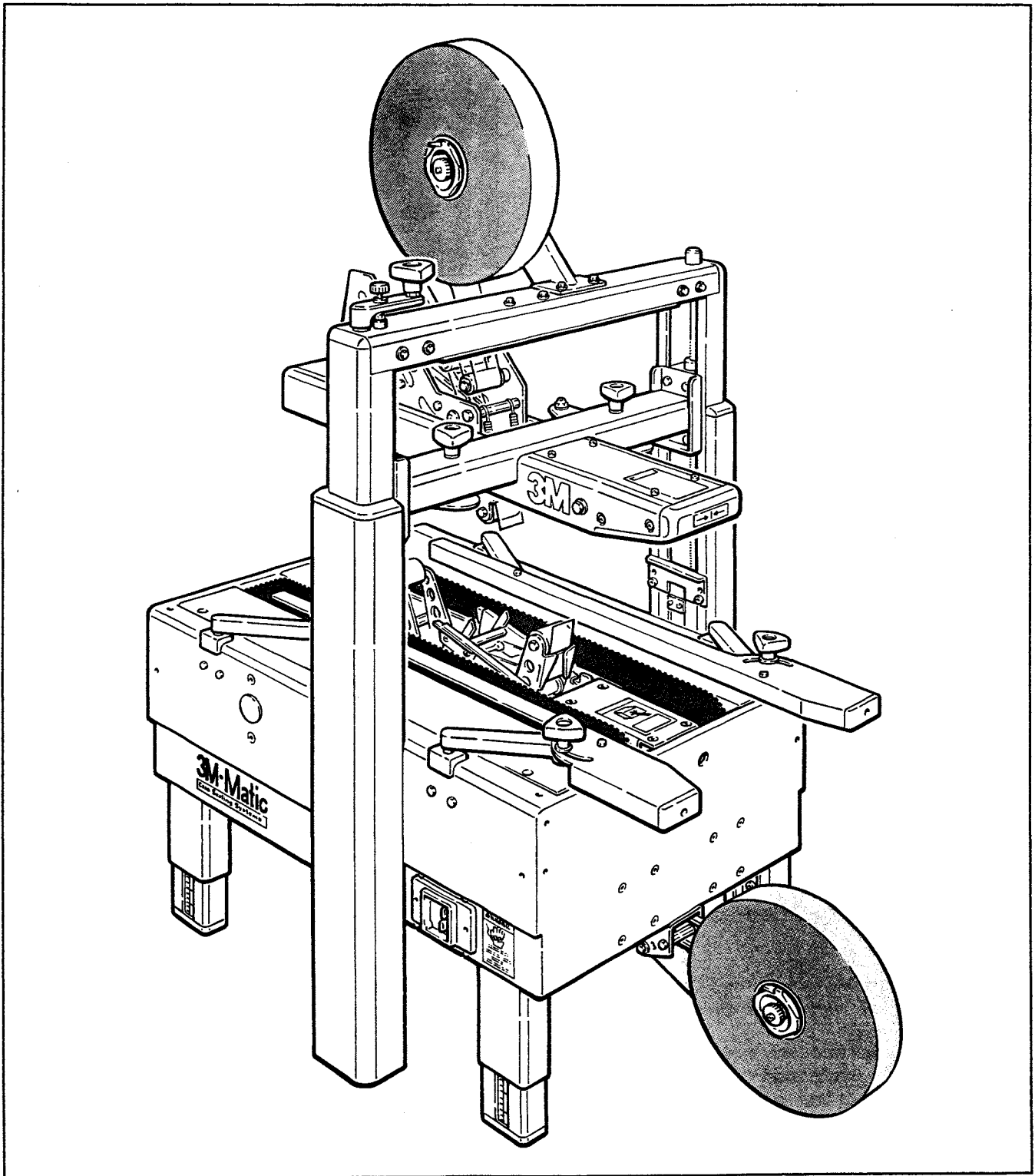

"3M-Matic" 200a Adjustable Case Sealer - Type 19000 (Note - lower tape supply roll and bracket assembly are shown in the alternate location)

Description

The "3M-Matic" 200a Adjustable Case Sealer with "AccuGlide" II Taping Heads is designed to apply a "C" clip of "Scotch" brand Pressure-sensitive Film Box Sealing Tape to the top and bottom center seam of regular slotted containers. The 200a is manually adjustable to a wide range of box sizes (see box size specifications).

IMPORTANT SAFEGUARDS

IN THE EVENT THESE SAFETY LABELS SHOWN ON PAGES 3-6 ARE DAMAGED OR DESTROYED, REPLACEMENTS ARE AVAILABLE. SEE PAGE 32.

There are three kinds of warning labels used on the case sealers.

The two illustrated labels (A-B) "Warning Sharp Knife", shown in figure 1-1, are attached to the sides of the upper frame at the location of the cut-off blade on the upper taping head. Two similar labels are attached to the bed frame at the location of the cut-off blade on the lower tape head. The labels warn operators and service personnel of the very sharp knife used to cut the tape at the end of the tape application.

The "Warning - Sharp Knife" label (C), shown in figure 1-1, is attached to the orange cut-off blade guard on both taping heads. The label warns the operator and service personnel of the very sharp knife located behind the guard and to keep hands out of this area except for tape loading and/or servicing the taping heads.

The taping heads are equipped with a orange blade guard that covers the blade. The taping heads should never be operated with the blade guards removed.

Turn air and electrical supplies off before servicing the taping heads.

The taping heads should not be washed down or subject to conditions causing moisture condensation on components.

The "Warning - Hazardous Voltage" label, shown in figure 1-2, is attached to the frame next to the on/off switch control box. The label warns service personnel to unplug the power supply before attempting any service work on the case sealer.

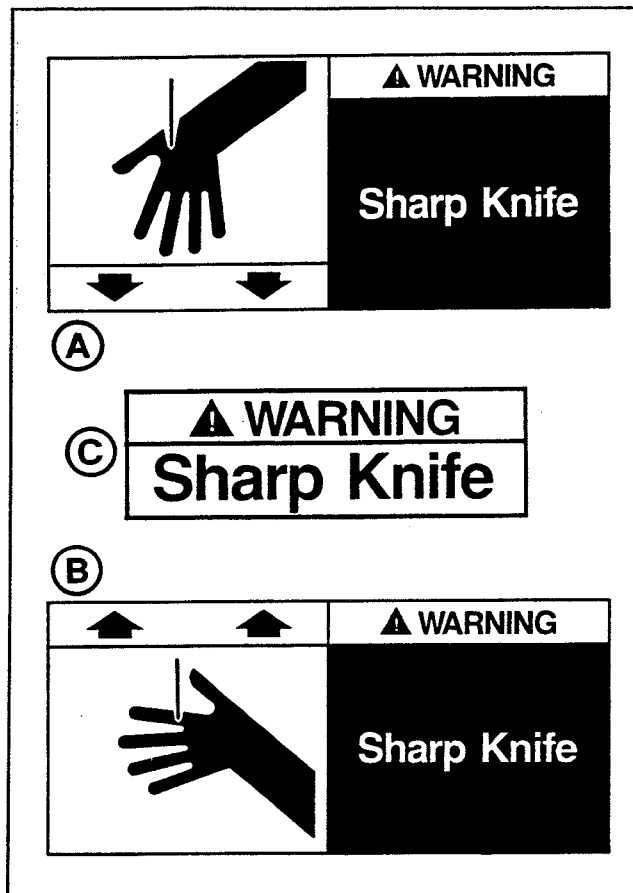

Figure 1-1 Knife Warning Labels

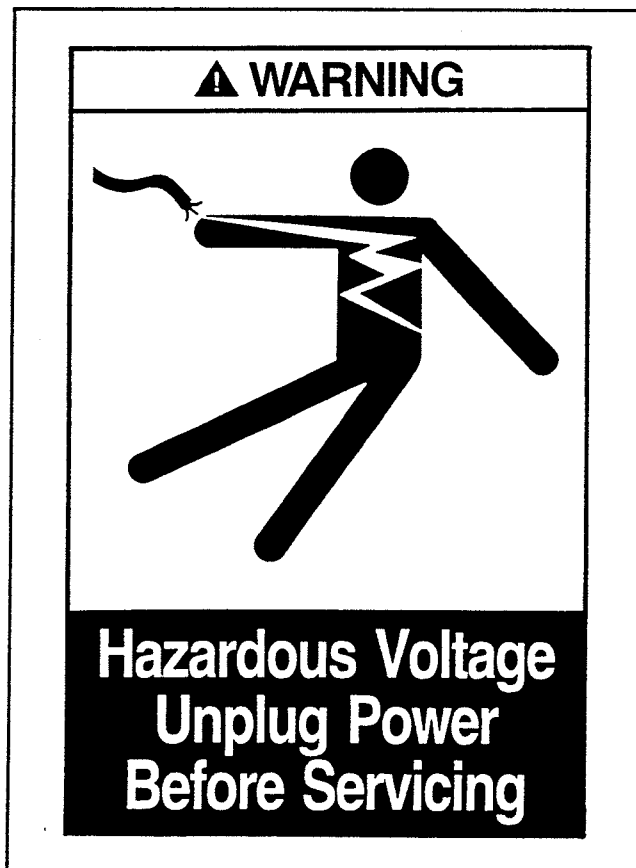

Figure 1-2 Electrical Warning Label

IMPORTANT SAFEGUARDS (Continued)

The "Caution - Keep Hands Out Of This Area" label, shown in figure 1-3, is attached to the center plate at the exit end of the bed frame. The label warns the operator to keep hands out of this area when the drive belts are running.



Figure 1-3 Hands Caution Label

The second "Caution - Keep Hands Out Of This Area" label, shown in figure 1-4, is attached to the rear of the upper frame. It warns the operator to keep hands out of this area when the upper taping head mechanism is in operation.



Figure 1-4 Hands Caution Label

IMPORTANT SAFEGUARDS (Continued)

The "Safety Instructions" label, shown in figure 1-5, is attached to the top front of the upper frame. The label provides convenient safeguard instructions for the operator and service personnel.

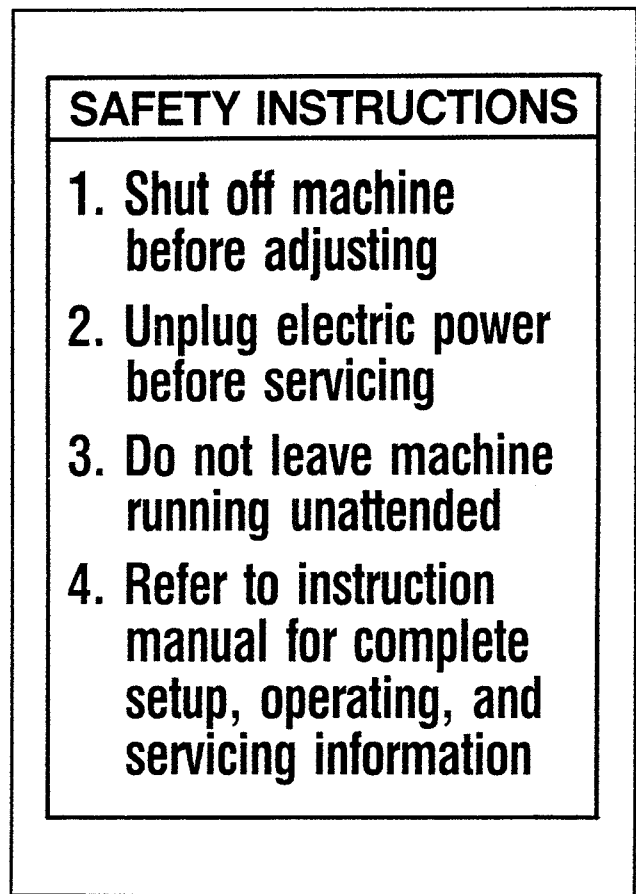

Figure 1-5 Safety Instruction Label

There are three operating note labels on the case sealer to remind the operator of important operating procedures.

The "Center Box Here" label, shown in figure 1-6, is attached to the front of the upper frame to remind the operator of the proper box placement procedure.

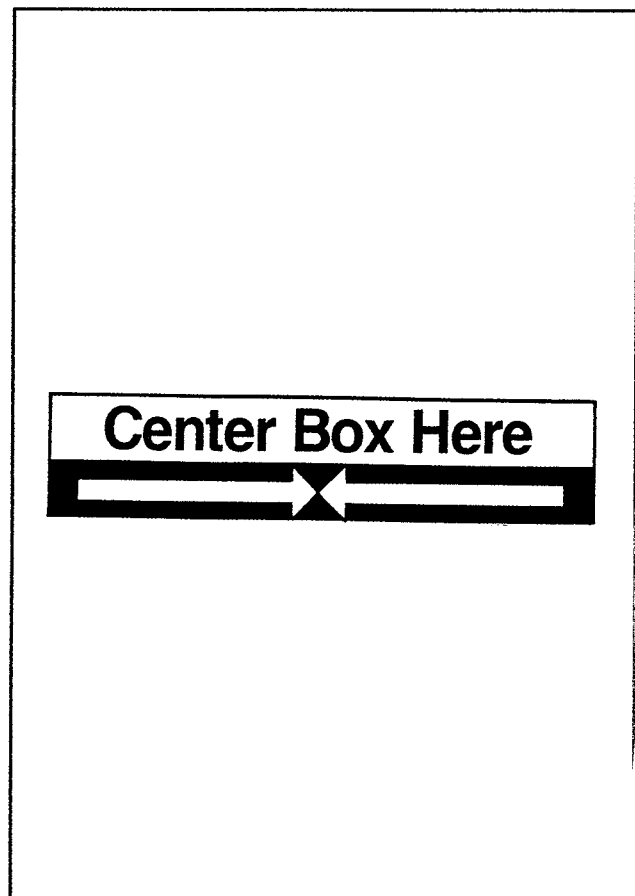

Figure 1-6 Center Box Label

IMPORTANT SAFEGUARDS (Continued)

The "Notice - Feed Box From This End" label, shown in figure 1-7, is attached to the center plate at the infeed end of the bed frame. It alerts the operator that this is the infeed end of the case sealer.



Figure 1-7 Box Feed Label

The "Tape Threading Label", shown in figure 1-8, is attached to the left side of both the upper and lower taping heads. This label provides a convenient tape threading diagram. More detailed tape loading and threading information is provided in this manual in the set-up procedure section.

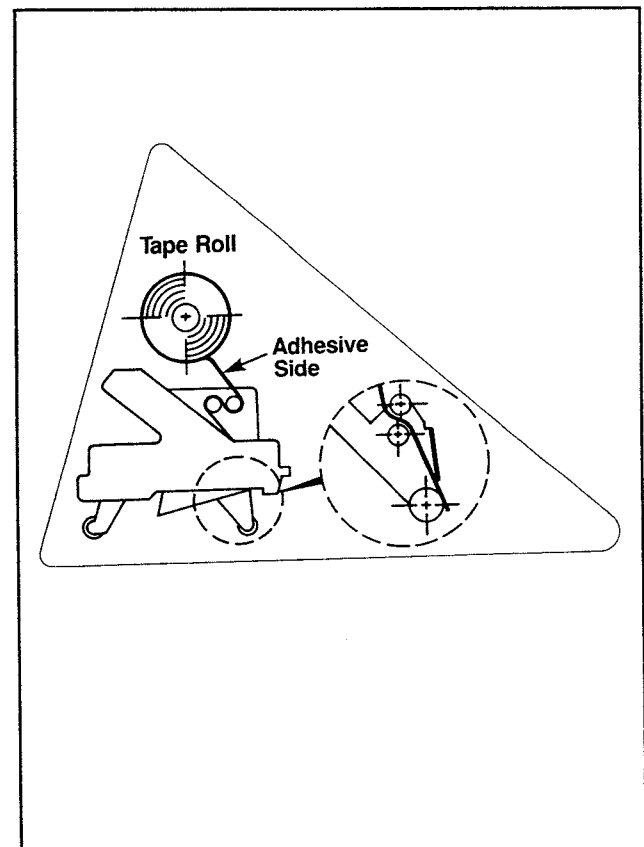



Figure 1-8 Tape Threading Label

 **THIS SAFETY ALERT SYMBOL IDENTIFIES IMPORTANT SAFETY MESSAGES IN THIS MANUAL. READ AND UNDERSTAND THEM BEFORE INSTALLING OR OPERATING THIS EQUIPMENT.**

Specifications

1. Power Requirements:

Electrical - 115 VAC, 60 Hz, 1.9A (220 watts)

The machine is equipped with a 1/6 HP gearmotor and comes with a standard neoprene covered power cord and a grounded plug. Contact your 3M Representative for power requirements not listed above.

2. Operating Rate:

BOXES PER MINUTE VS. BOX LENGTH

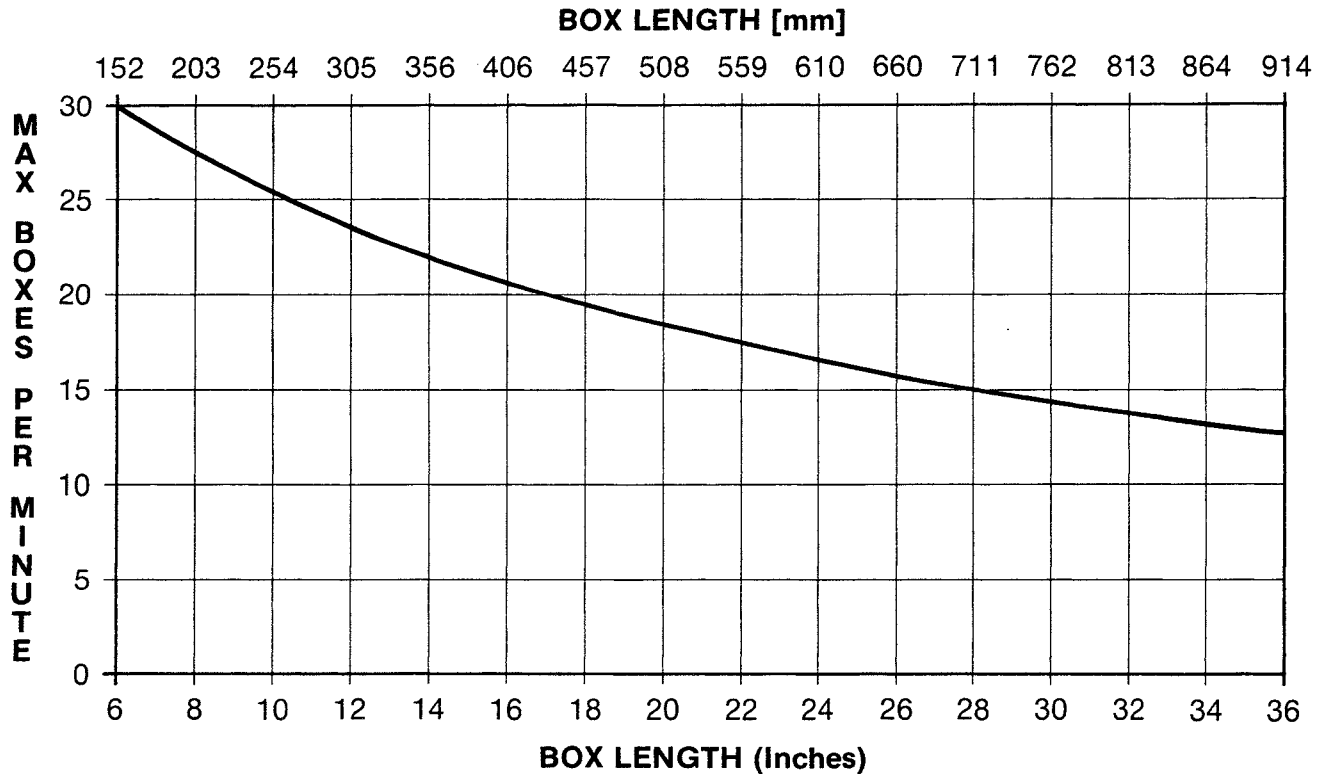

Actual production rate is dependent on operator's dexterity.

Boxes must be 18 inches [455 mm] apart minimum.

3. Operating Conditions:

Use in dry, relatively clean environments at 40° to 105°F [5° to 40°C] with clean, dry boxes.

IMPORTANT SAFEGUARD

Machine should not be washed down or subjected to conditions causing moisture condensation on components.

(Specifications continued on next page.)

Specifications (Continued)

4. Tape:

"Scotch" brand pressure-sensitive film box sealing tapes.

5. Tape Width:

1 1/2 inches or 36 mm minimum to 2 inches [50 mm] maximum.

6. Tape Roll Diameter:

Up to 16 inches [405 mm] maximum on a 3 inch [76,2 mm] diameter core.
(Accommodates all system roll lengths of "Scotch" brand film tapes.)

7. Tape Application Leg Length - Standard:

2 3/4 inches \pm 1/4 inch [70 mm \pm 6 mm]

Tape Application Leg Length - Optional:

2 inches \pm 1/4 inch [50 mm \pm 6 mm]

8. Box Board:

Style - regular slotted container - RSC
125 to 275 P.S.I. bursting test, single wall or double wall B or C flute.

9. Box Weight and Size Capacities:

A. Box weight, filled - 5 lbs. [2,3 kg] **minimum**, 85 lbs. [38,6 kg] **maximum**

B. Box size:	Minimum	Maximum
Length -	6.0 inches [150 mm]	unlimited
Width -	6.0 inches [150 mm]*	21.5 inches [550 mm]
Height -	4.8 inches [120 mm]**	24.5 inches [620 mm]

* **Note:** Cartons smaller than 10 inches or 250 mm in width may require more frequent belt replacement because of limited contact area.

** 3.5 inches [90 mm] height with heads adjusted to apply 2 inch [50 mm] tape legs lengths.

Special modifications may be available for carton sizes not listed above.
Contact your 3M Representative for information.

Note: The case sealer can accommodate most boxes within the size range listed above. However, if the box length (in direction of seal) to box height ratio is .75 or less, then several boxes should be test run to assure proper machine performance.

DETERMINE THE BOX LIMITATIONS BY COMPLETING THIS FORMULA:

$$\frac{\text{BOX LENGTH IN DIRECTION OF SEAL}}{\text{BOX HEIGHT}} \quad \text{SHOULD BE GREATER THAN } .75$$

Any box ratio approaching this limitation should be test run to assure performance.

(Specifications continued on next page.)

Specifications (Continued)

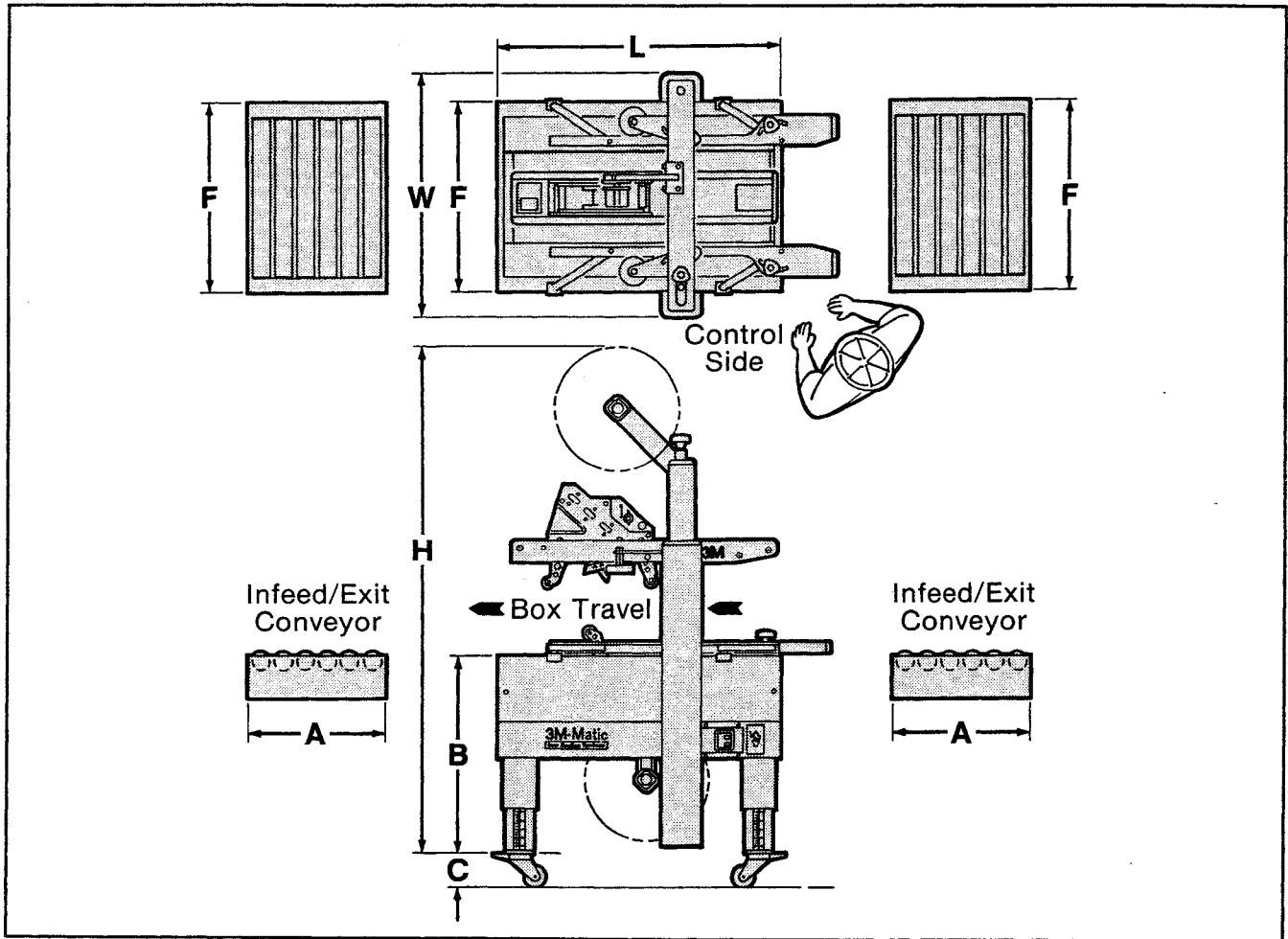

10. Machine Dimensions:

	W	L	H	A*	B	C**	F
Minimum							
inches [mm]	31 [790]	36 1/2 [930]	53 [1350]	18 [460]	24 [610]	4 [100]	24 1/2 [620]
Maximum							
inches [mm]	--	--	86 [2190]	--	35 [890]	--	--

* Infeed/Exit conveyors are optional

** Casters are optional

Weight - approximate 320 pounds [145,6 kg] crated
 approximate 280 pounds [123,4 kg] uncrated

11. Set-Up Recommendations:

- > Machine must be level.
- > Customer supplied infeed and exit conveyors (if used) should provide straight and level box entry and exit.
- > Exit conveyors (powered or gravity) must convey sealed boxes away from machine.

Set-Up Procedure

It is recommended that the 200a Case Sealer be set-up and operated with product before placing it in the production line. This approach will allow your thorough review and familiarization with the 200a before subjecting it and operating personnel to a production situation where time for set-up, adjustments, and operator training usually becomes limited.

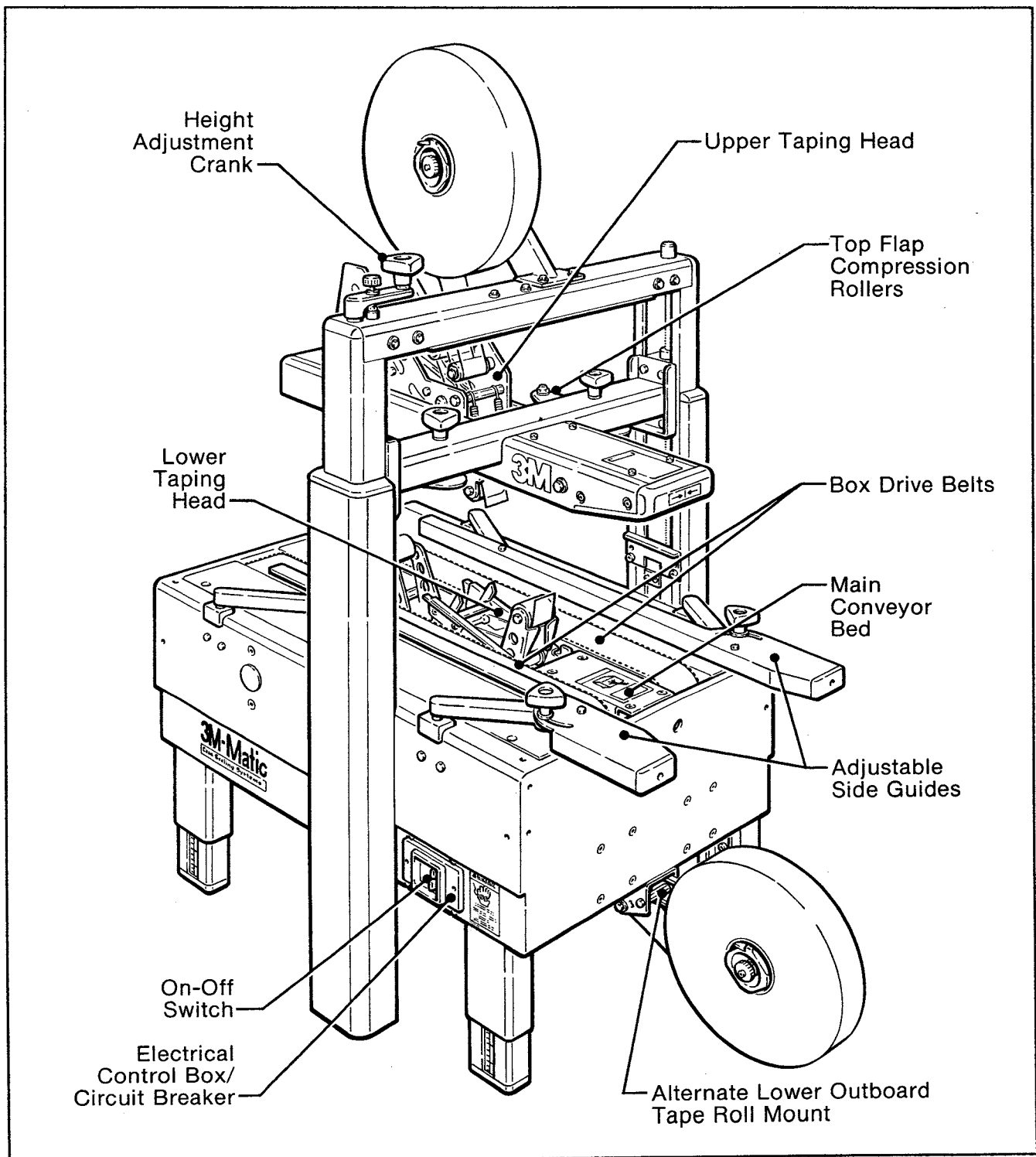

Figure 2-1 - Set-Up Instructions - Case Sealer Components - Left Front View

Set-Up Procedure (Continued)

Receiving And Handling

After the machine has been uncrated, examine the Case Sealer for damage that might have occurred during transit. If damage is evident, file a damage claim immediately with the transportation company and also your 3M Representative.

The following instructions are presented in the order recommended for setting up and installing the case sealer, as well as for learning the operating functions and adjustments. Following them step by step will result in your thorough understanding of the machine and an installation in your production line that best utilizes the many features built into the case sealer.

1. Lift off fiberboard cover from pallet after removing staples at bottom.
2. Remove the two "U" shaped hold down clamps from lower cross bar. These are sheet metal brackets that prevent the upper head assembly from bouncing during shipping.
3. Install the crank handle on the top of the left column, as shown in figure 2-2A.
4. Install the upper tape drum bracket on the top cross bar, as shown in figure 2-2B.
5. Raise upper head assembly (turn crank handle counterclockwise). Remove the two shipping stop angle brackets and discard. Install the machine stops (from parts bag). Mount these stops as shown in figure 2-2C. Use the lowest hole position and bolt into the lowest threaded insert on the column. The upper hole position in the stops should only be used when the heads are adjusted to apply 2 inch tape legs.
6. Ensure that the tape drum bracket assembly, located on the lower taping head, is mounted straight down, as shown in figure 2-3A. The tape drum bracket assembly can be pivoted to provide clearance or for retrofit in certain cases.

Lower Outboard Tape Roll Mount - Alternate

Remove the tape drum bracket assembly, stud spacer and fasteners from the lower taping head. Install and secure on the infeed end of the lower frame, as shown in figure 2-3B.

Conveyor Bed Height

The case sealer is equipped with four adjustable legs that are located at the corners of the frame. The legs can be adjusted to obtain different machine conveyor bed heights from 24 inches [610 mm] minimum to 35 inches [890 mm] maximum.

Refer to Figure 2-3C and set the conveyor bed height as follows:

1. Block up the machine frame to allow adequate leg adjustment.
2. Loosen, but do not remove, two M8 x 1,25 mm socket head screws in one leg (use M6 hex wrench). Adjust the leg length for the desired conveyor bed height. Retighten the two screws to secure the leg. Adjust all four legs as noted.

Set-Up Procedure (Continued)

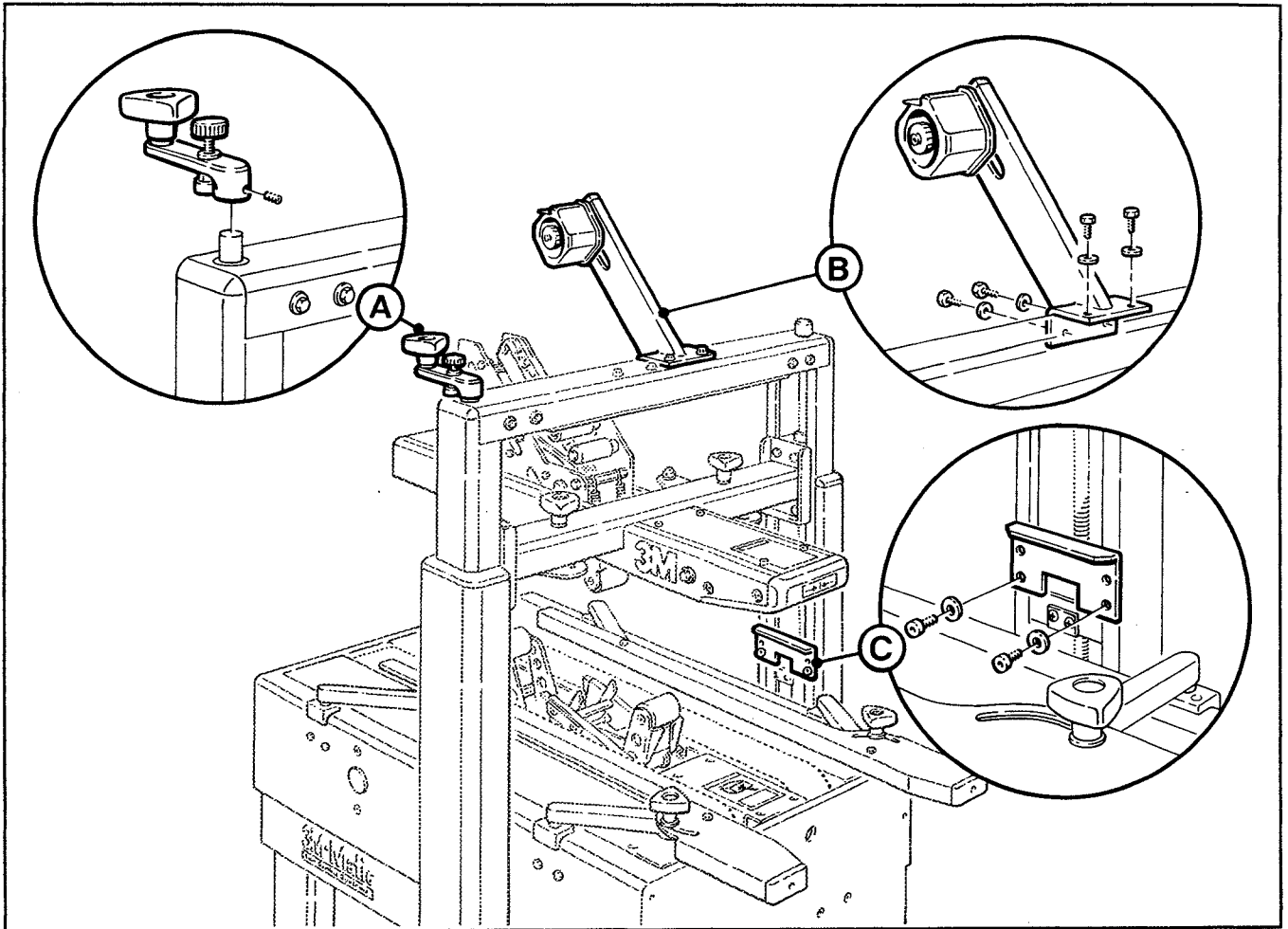

Figure 2-2 - Set-Up and Installation

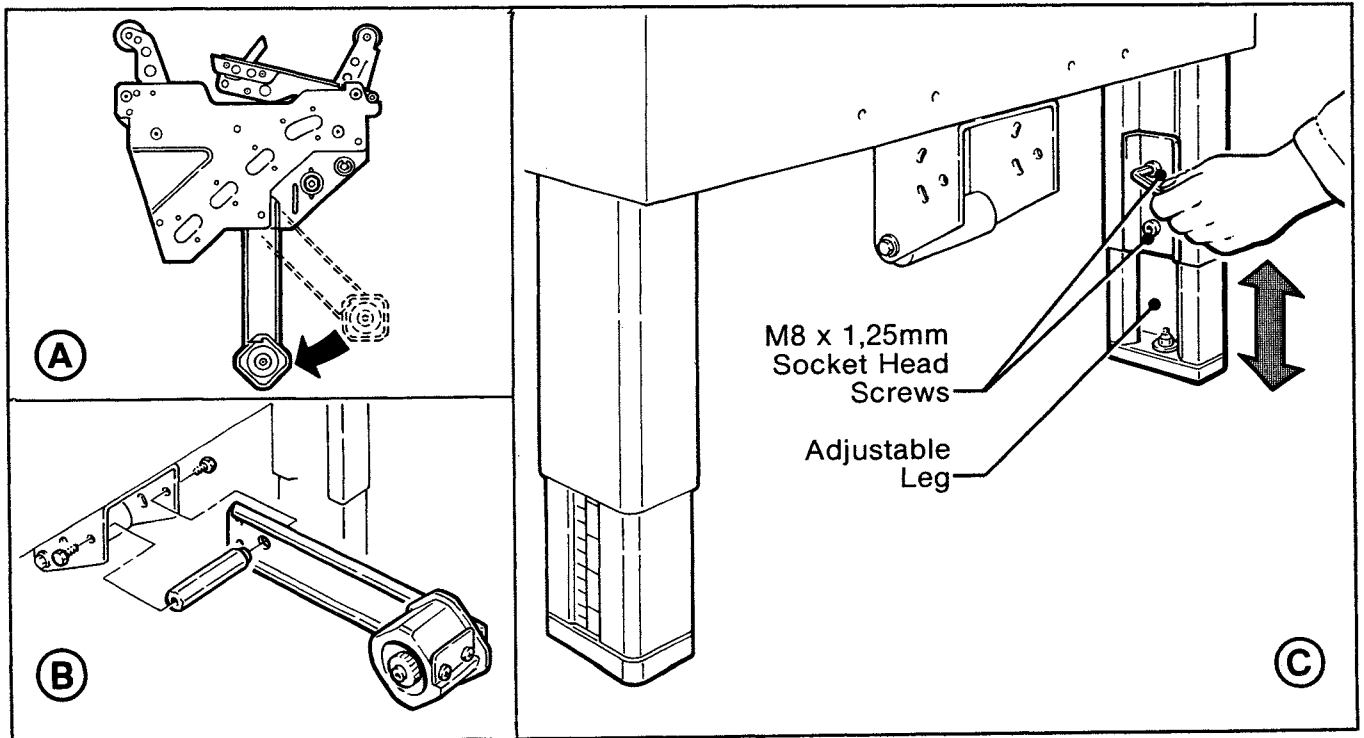

Figure 2-3 - Conveyor Bed Height Adjustment and Lower Tape Drum Bracket Position

IMPORTANT SAFEGUARDS

1. BOTH THE UPPER AND LOWER TAPING HEADS UTILIZE EXTREMELY SHARP KNIFE BLADES. THE BLADES ARE LOCATED UNDER THE ORANGE BLADE GUARD WHICH HAS THE "WARNING - SHARP KNIFE" LABEL. BEFORE WORKING WITH THE TAPING HEADS OR ATTEMPTING TO LOAD THE TAPE, REFER TO FIGURES 2-4 AND 2-5 AND IDENTIFY THE BLADE LOCATION. KEEP HANDS OUT OF THESE AREAS EXCEPT AS NECESSARY TO SERVICE THE TAPING HEADS.
2. NEVER ATTEMPT TO WORK ON THE TAPING HEADS OR LOAD TAPE WHEN THE BOX DRIVE BELTS ARE RUNNING.

Tape Loading

The taping head accommodates up to 2 inch [50 mm] wide tape rolls. To apply 1 1/2 inch or 36 mm or 1 3/4 inch or 42 mm wide tapes, refer to "Adjustments Section" for set-up information.

A plastic threading needle is provided with each machine and it is recommended that the detailed instructions and sketches in this manual be referred to the first few times the unit is loaded and until the operator becomes thoroughly familiar with the tape loading operation.

Tape Loading - Upper Taping Head



WARNING - TURN OFF ELECTRICAL POWER SUPPLY AND DISCONNECT POWER CORD FROM ELECTRICAL SUPPLY BEFORE BEGINNING WORK ON THE TAPING HEADS OR TO LOAD TAPE. IF POWER CORD IS NOT DISCONNECTED, SEVERE INJURY TO PERSONNEL COULD RESULT.

1. It is first necessary to raise the upper taping head frame to a convenient working position.
2. For tape loading operations, use the plastic threading needle and follow the loading procedures (figures 2-6 to 2-8) to complete the tape threading.

Tape Loading - Lower Taping Head

1. For ease in set-up loading, first remove the lower taping head from the conveyor bed. Lift the head straight up from the conveyor bed.
2. The lower taping head is loaded and threaded in the same manner as the upper taping head. Follow the upper taping head tape loading procedure.
3. Replace the lower taping head.

Set-Up Procedure (Continued)

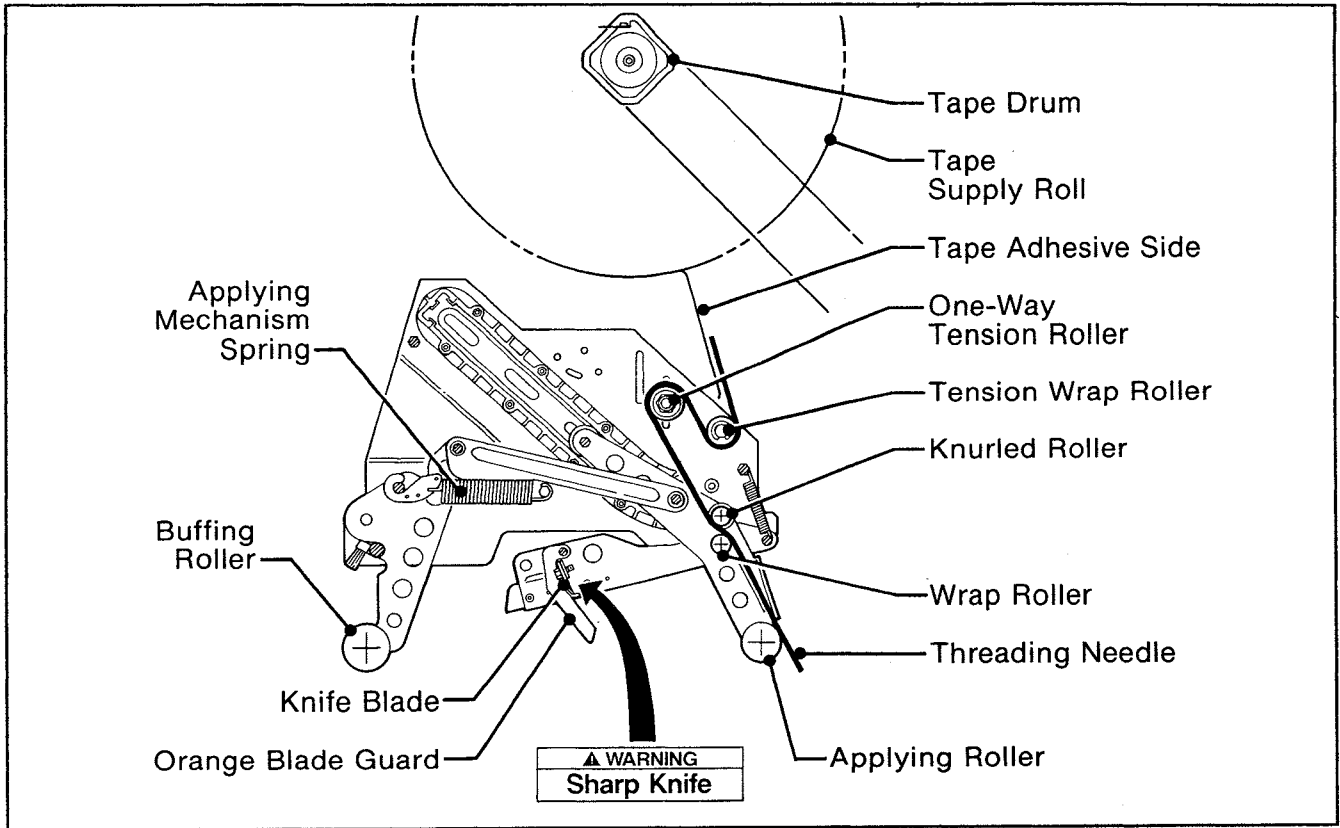

Figure 2-4 - Tape Threading Diagram - Upper Taping Head - Left Side View

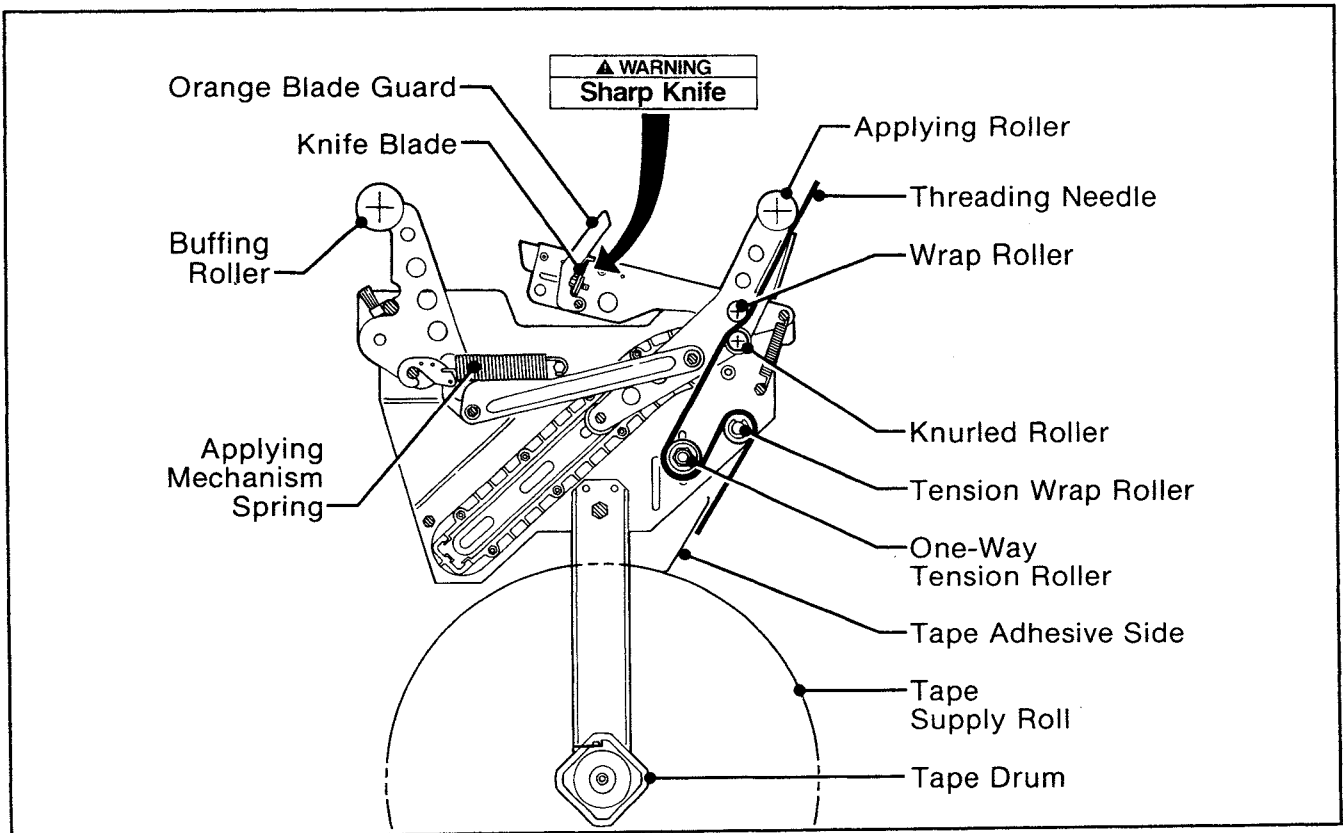

Figure 2-5 - Tape Threading Diagram - Lower Taping Head - Left Side View

Set-Up Procedure (Continued)

Figure 2-6

Insert the plastic needle downward around rollers as illustrated.

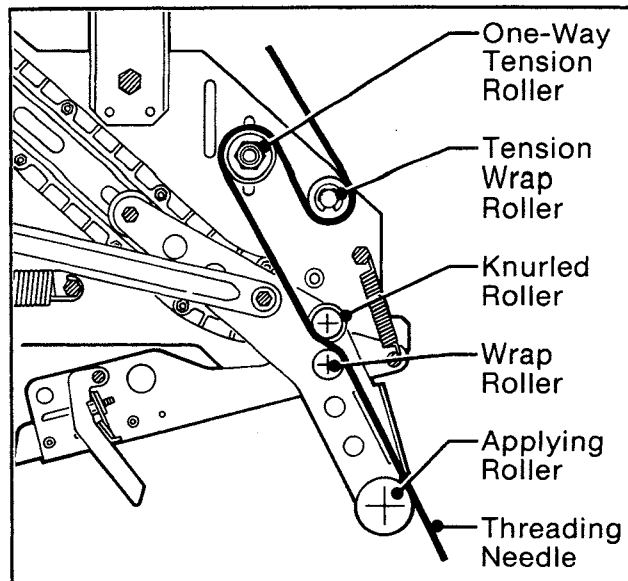

Figure 2-6

Figure 2-7

Place tape roll on drum to dispense tape from bottom of roll adhesive side forward. Seat tape roll fully against back flange of drum. Adhere tape lead end to upper end of threading needle as shown.

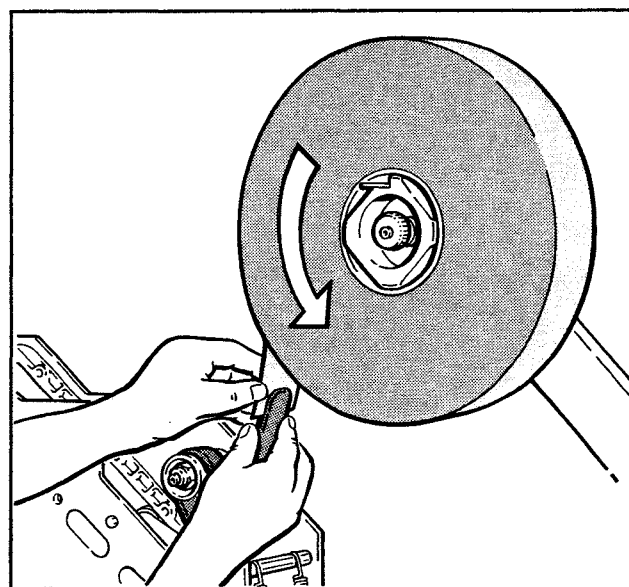

Figure 2-7

Figure 2-8

! WARNING - USE CARE WHEN WORKING NEAR BLADES AS BLADES ARE EXTREMELY SHARP. IF CARE IS NOT TAKEN, SEVERE INJURY TO PERSONNEL COULD RESULT.

Manually turn tape roll to create slack tape while pulling threading needle through tape applying mechanism until needle is through and tape is in alignment with applying roller.

Excess tape can be cut with a scissors at applying roller.

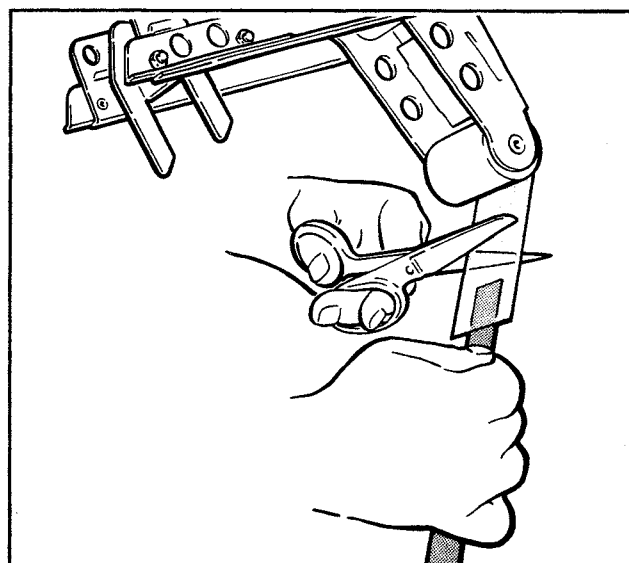

Figure 2-8

Set-Up Procedure (Continued)

Electrical Connection

The electrical control box, shown in Figure 2-1, contains the "On-Off" switch with pre-set circuit breaker and can be located on either side of the main conveyor for customer operating convenience. An 8 foot [2,4 m] standard three conductor power cord with plug is provided at the back of the electrical control box for 115 Volt, 60 Hz, 1.9 Amp electrical service. The receptacle providing this service shall be properly grounded. Before the power cord is plugged into 115 Volt, 60 Hz outlet, make sure the switch is "Off" and that all packaging materials and tools are removed from the machine.

Note - Machines outside the U.S. may be equipped with 220/240 Volt, 50 Hz systems, or other electrical requirements compatible with local practice.

Box Size Set-Up and Operation

Figure 2-9

Once both taping heads are loaded with tape, the upper taping head can be positioned for the box height being sealed by means of the height adjustment crank. Turn clockwise to lower head, counterclockwise to raise head.

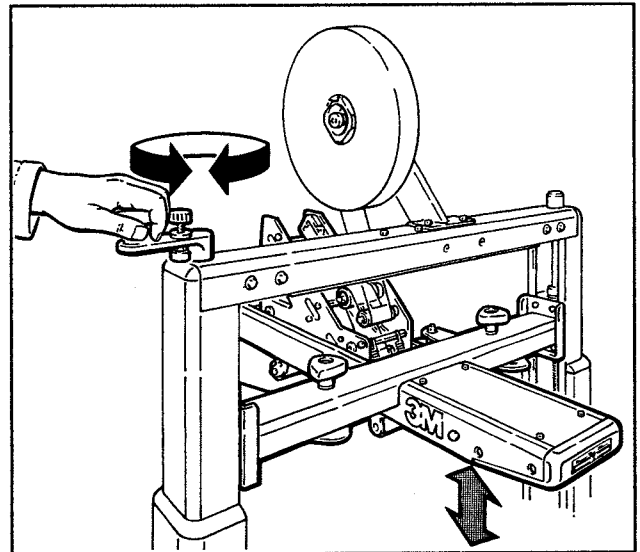

Figure 2-9

Figure 2-10

Place box on infeed end of frame bed with both top and bottom flaps folded and insert under upper head ski approximately 6 inches or 50 mm. Lower the head until all flaps are fully closed. Align box top flap center seam with arrows on front of ski.

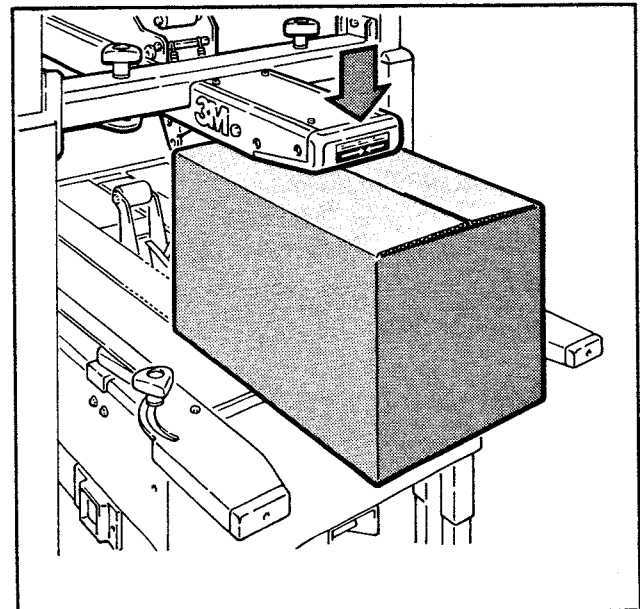

Figure 2-10

Set-Up Procedure (Continued)

Figure 2-11

Move side guides against each side of box to hold box in position, centered on arrows on front of ski. Tighten hand knobs to secure side guides.

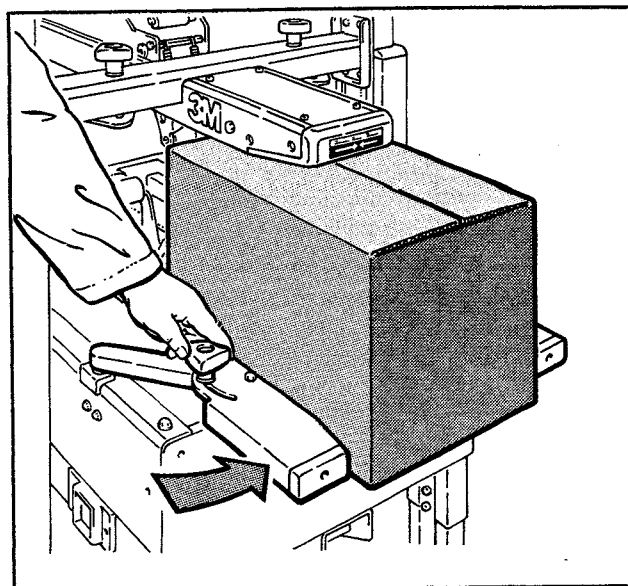

Figure 2-11

Figure 2-12

Turn electrical switch to "On" to start drive belts. Move box forward under upper taping head until it is taken away by drive belts. If box is hard to move under head or is crushed, raise head slightly. If box movement is jerky or stops under upper head, lower top head slightly to add more pressure between box and drive belts.

Note: Upper head has unique feature for overstuffed boxes. The head will raise up to 1/2 inch or 13 mm to compensate for this type of condition.

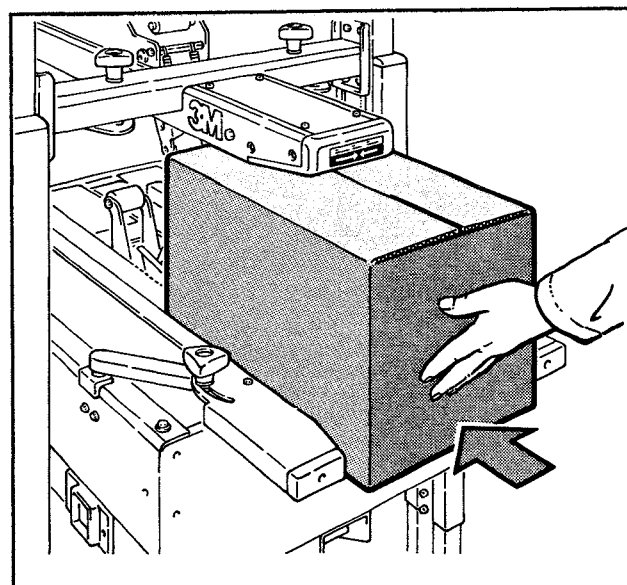

Figure 2-12



CAUTION - IF DRIVE BELTS ARE ALLOWED TO SLIP ON BOX, EXCESSIVE BELT WEAR WILL OCCUR.

Figure 2-13

Adjust the flap compression rollers against top edge of box and tighten knobs to secure rollers in operating position.

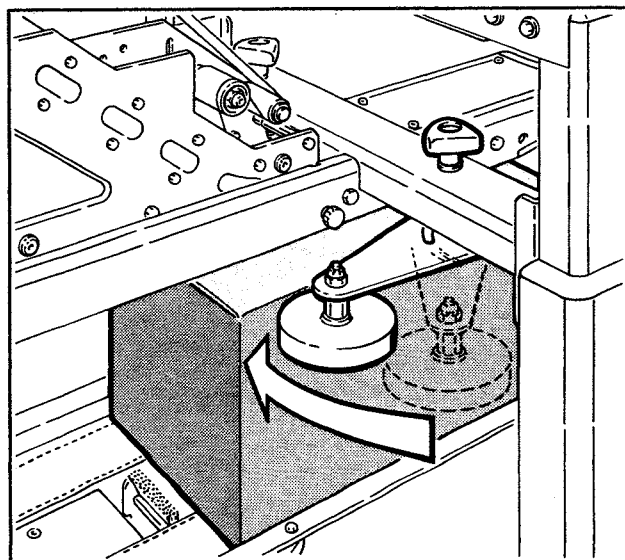

Figure 2-13

THIS PAGE IS BLANK

Adjustments

⚠ WARNING - TURN OFF ELECTRICAL POWER AND DISCONNECT POWER CORD FROM ELECTRICAL SUPPLY BEFORE BEGINNING ADJUSTMENTS. IF POWER CORD IS NOT DISCONNECTED, SEVERE INJURY TO PERSONNEL COULD RESULT.

Tape Web Alignment

Figure 3-1

The tape drum assembly on each taping head is pre-set to accommodate 2 inch [50 mm] wide tape, but is adjustable to provide alignment of narrower tapes. If adjustment is necessary to center the tape width on the centerline of the taping head, (and therefore box center seam), make adjustment as follows:

1. Loosen locking hex nut behind tape drum on tape drum shaft. Use an adjustable wrench or 25 mm open end wrench.
2. Turn tape drum shaft in or out to center the tape web (use 5 mm hex wrench).
3. Tighten locking hex nut to secure the adjustment.

No other components require adjustment for tape web alignment.

Tape Drum Friction Brake

Figure 3-2

The tape drum friction brake on each taping head is pre-set for normal operation to prevent tape roll over travel. Should tension adjustment be required, turn the thumbwheel on the shaft to vary compression of the spring. Turn thumbwheel clockwise to increase the braking force, and counterclockwise to decrease the braking force. Adjust to minimum tension that prevents excessive tape roll over travel.

Note - excess braking force will cause poor tape application and may lead to tape tabbing on the trailing tape leg.

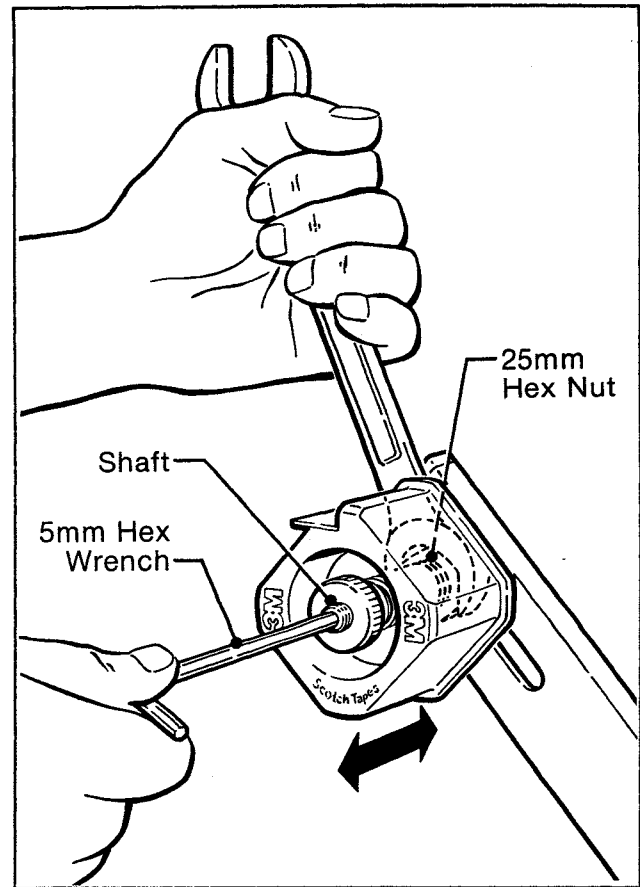

Figure 3-1

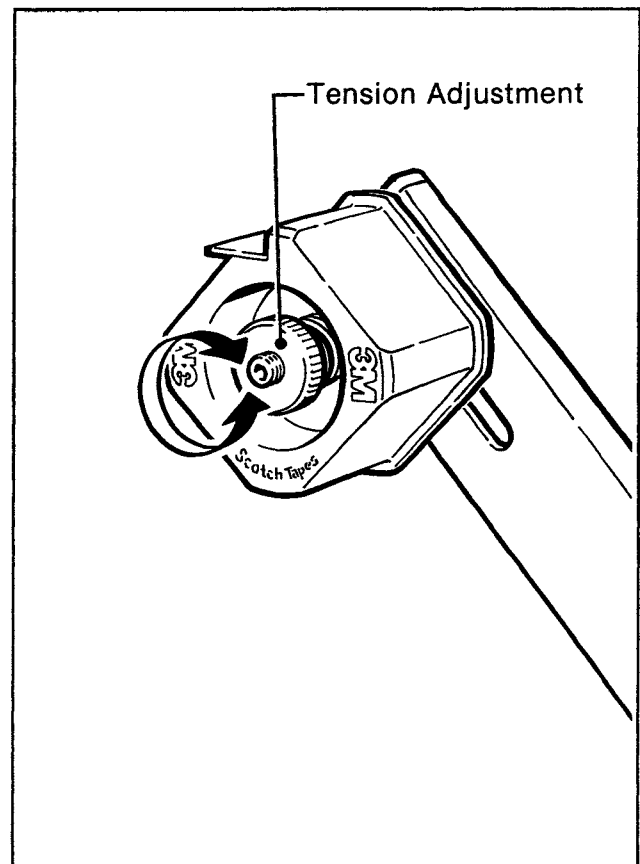

Figure 3-2

Adjustments (Continued)

⚠ WARNING - TURN OFF ELECTRICAL POWER AND DISCONNECT POWER CORD FROM ELECTRICAL SUPPLY BEFORE BEGINNING ADJUSTMENTS. IF POWER CORD IS NOT DISCONNECTED, SEVERE INJURY TO PERSONNEL COULD RESULT.

Applying Mechanism Spring Figure 3-3

The applying mechanism spring, shown in figures 2-4 and 2-5, controls applying and buffing roller pressure on the box and returns the mechanism to the reset position. The spring pressure setting, as shown in figure 3-3A, is for normal operation but is adjustable.

Removing the spring end loop from the spring holder and placing loop in other holes provided, as shown in Figure 3-3B, will adjust the spring pressure.

The spring pressure should be set to the minimum possible while maintaining good tape application.

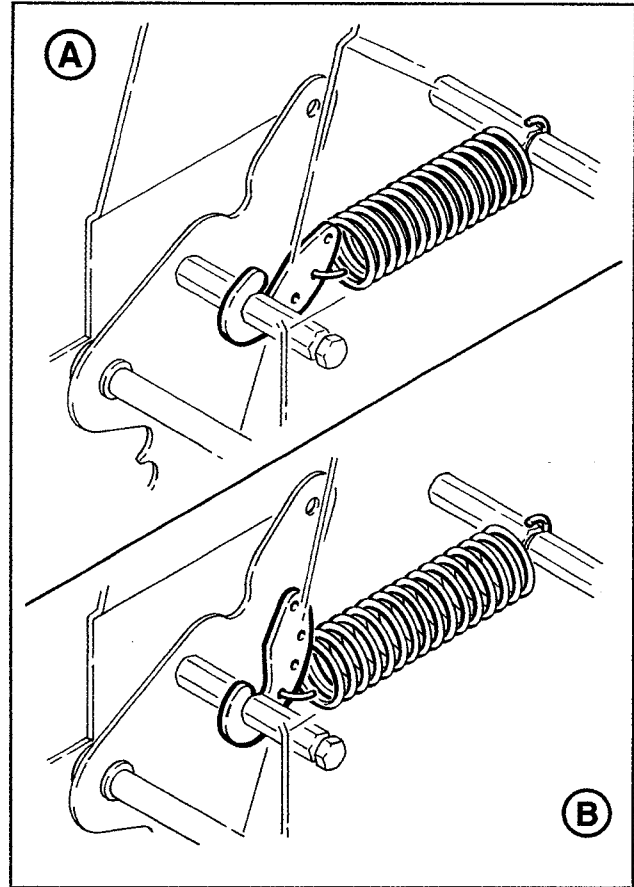

Figure 3-3

One Way Tension Roller Assembly Figure 3-4

The one way tension roller is factory set. When replacing this assembly, the roller must have 1 lb. [0,5 kg] minimum tangential force when turning.

To Set Tension:

1. Wrap a cord or small strap (non-adhesive) 4-6 turns around the tension roller.
2. Attach a spring scale to the end of the cord or strap.
3. Turn the adjusting nut until a force of approximately 1-2 lbs. [0,5 kg to 0,9 kg] is required to turn the roller by pulling on the spring scale.

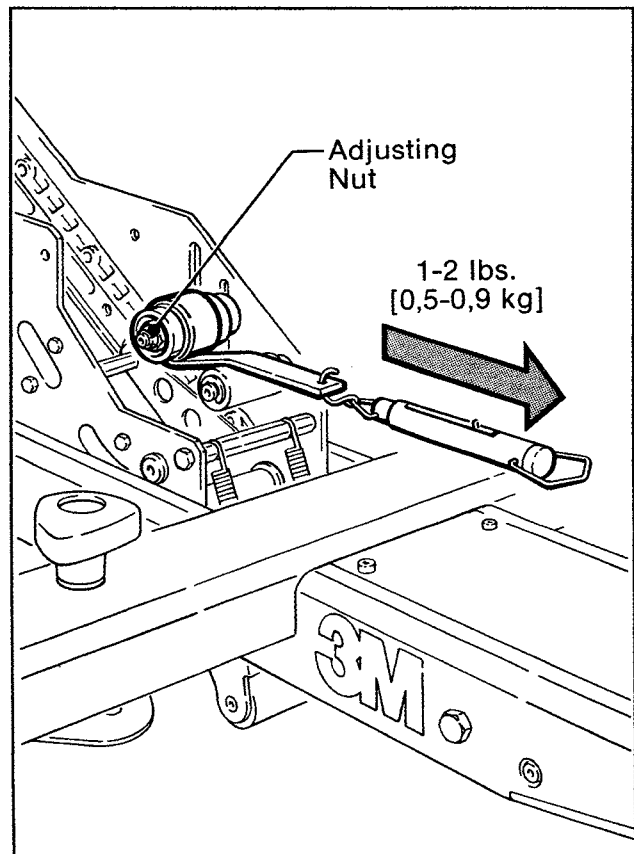

Figure 3-4



WARNING - TURN OFF ELECTRICAL POWER AND DISCONNECT POWER CORD FROM ELECTRICAL SUPPLY BEFORE BEGINNING ADJUSTMENTS. IF POWER CORD IS NOT DISCONNECTED, SEVERE INJURY TO PERSONNEL COULD RESULT.

Box Drive Belt Tension

The two continuously moving box drive belts convey boxes through the tape applying mechanism. The box drive belts are powered by an electric gear motor.

Tension adjustment of these belts may be required during normal operation. Belt tension must be adequate to positively move the box through the machine and they should run fully on the surface of the pulleys at each end of the frame. The idler pulleys on the infeed end are **adjusted in or out to provide proper belt tension**. Each belt is adjusted separately.

Belt tension is obtained by tightening the adjustment screws so that a moderate pulling force of 7 lbs. [3,5 kg] applied at the midspan, as shown in Figure 3-5, will deflect the belt 1 inch [25 mm]. This will assure positive contact between the belt and the drive pulley on the discharge end of the taping head.

Refer to Figure 3-6 and adjust belt tension as follows:

- Step 1. **Remove and retain center plate and four screws.**
- Step 2. **Loosen, but do not remove, lock nut M10 with a 17 mm open end wrench.**
- Step 3. **Reset the tension on the drive belt as needed. Use M6 hex wrench and adjust the M8 socket head tension screws in (clockwise) to increase tension or out (counterclockwise) to decrease tension. Tighten lock nut to secure tension setting.**
- Step 4. **Replace center plate and secure with original screws.**

Adjustments (Continued)

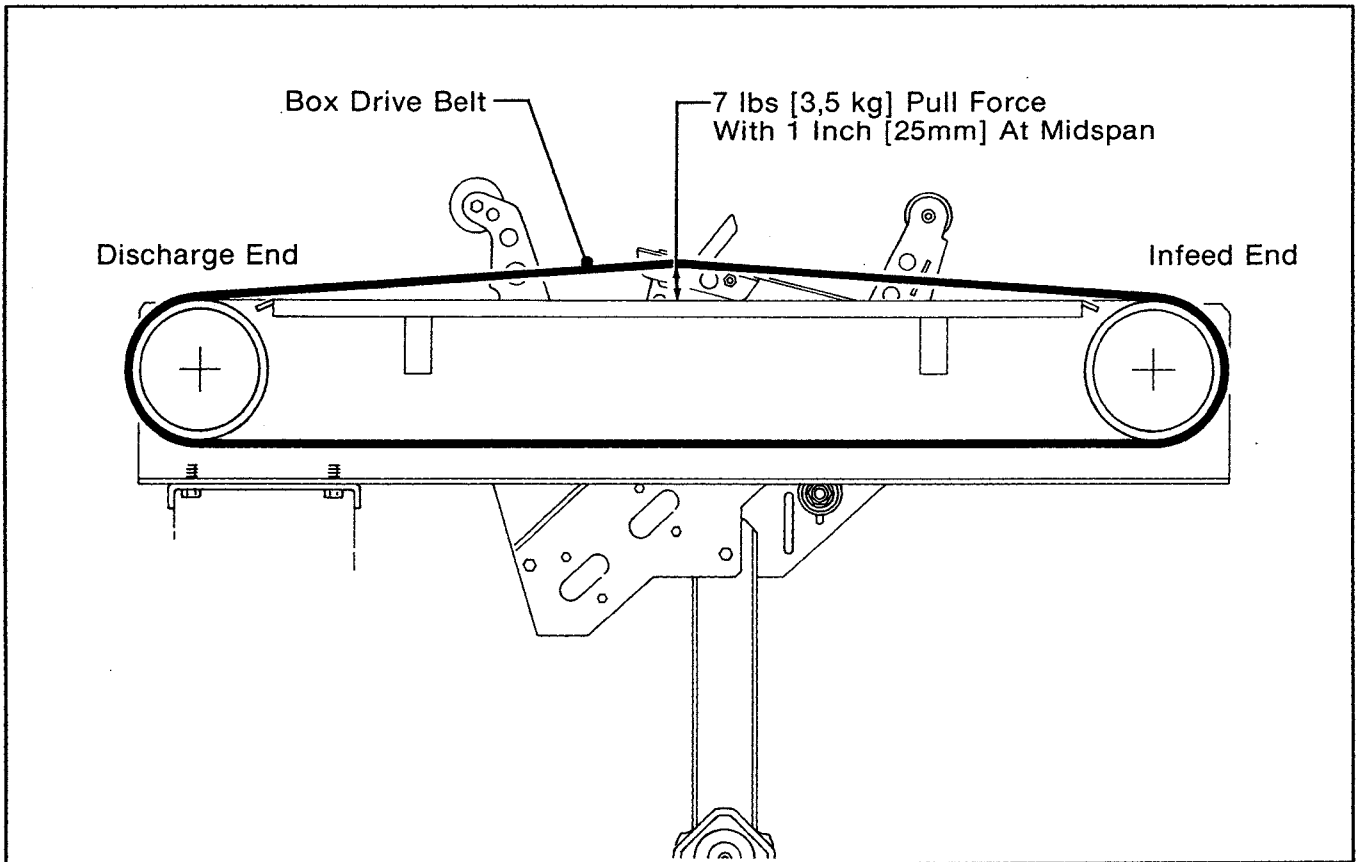

Figure 3-5 - Box Drive Belt Tension Adjustment - Left Side View

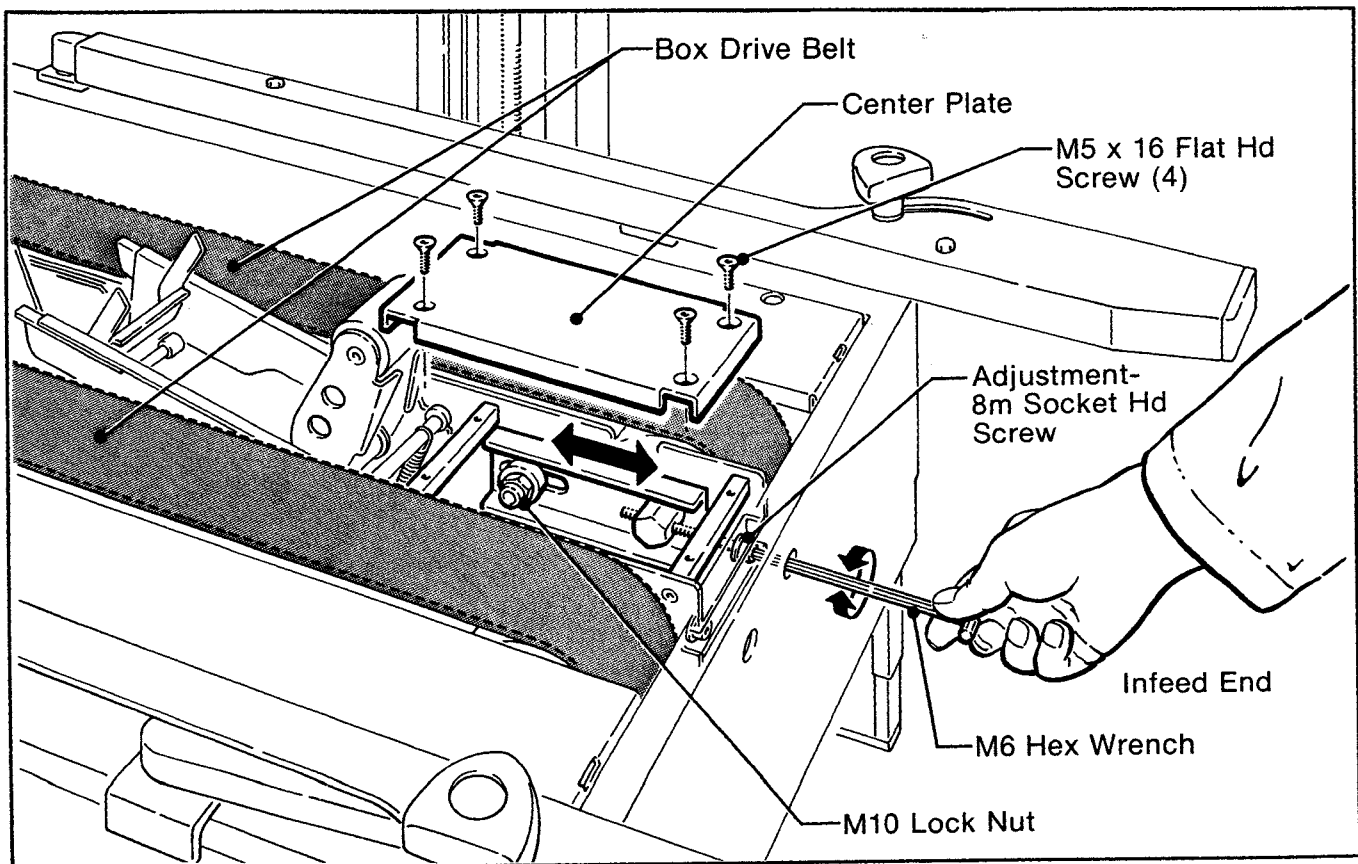

Figure 3-6 - Box Drive Belt Tension Adjustment - Frame Bed Infeed End

Adjustments (Continued)

⚠ WARNING - TURN OFF ELECTRICAL POWER AND DISCONNECT POWER CORD FROM ELECTRICAL SUPPLY BEFORE BEGINNING ADJUSTMENTS. IF POWER CORD IS NOT DISCONNECTED, SEVERE INJURY TO PERSONNEL COULD RESULT.

Tape Application Leg Length
Figure 3-7

For best tape application performance, the taping heads should maintain tape leg lengths of $2\frac{3}{4}$ inch \pm $\frac{1}{4}$ inch [70 mm \pm 6 mm].

The one-way tension roller position on the taping head is adjustable to control the leading tape leg length.

Refer to Figure 2-6

Moving this roller farther away from the box top surface will decrease the leading leg length. Moving it closer to the box top surface will increase the leading leg length.

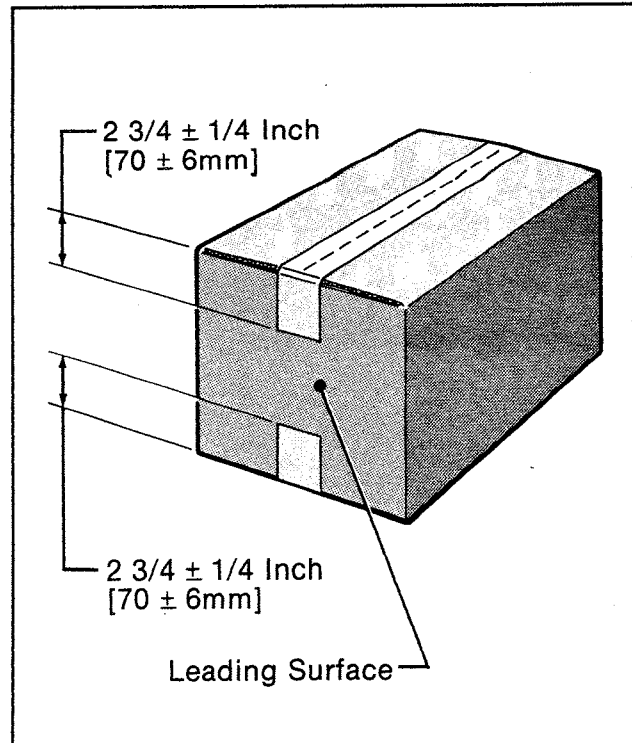

Figure 3-7 - Adjusting Tape Leg Length

Maintenance

The case sealer has been designed for long, trouble free service. The machine will perform best when it receives routine maintenance and cleaning. Machine components that fail or wear excessively should be promptly repaired or replaced to prevent damage to other portions of the machine or to the product.

⚠ WARNING - TURN OFF ELECTRICAL POWER SUPPLY AND DISCONNECT POWER CORD FROM ELECTRICAL SUPPLY BEFORE BEGINNING MAINTENANCE. IF POWER CORD IS NOT DISCONNECTED, SEVERE INJURY TO PERSONNEL COULD RESULT. USE CARE WHEN REPLACING BLADES AS BLADES ARE EXTREMELY SHARP. IF CARE IS NOT TAKEN, SEVERE INJURY TO PERSONNEL COULD RESULT.

Blade Replacement

Figure 4-1

1. Loosen, but do not remove, the blade screws (A). Remove and discard the old blade.
2. Mount the new blade (B) with the beveled side away from the blade holder.
3. Bottom the blade slots against the screws. This will position the blade at the correct angle. Tighten the blade screws to secure the blade.

The same steps are followed on the upper and lower taping heads. Connect the main power supply.

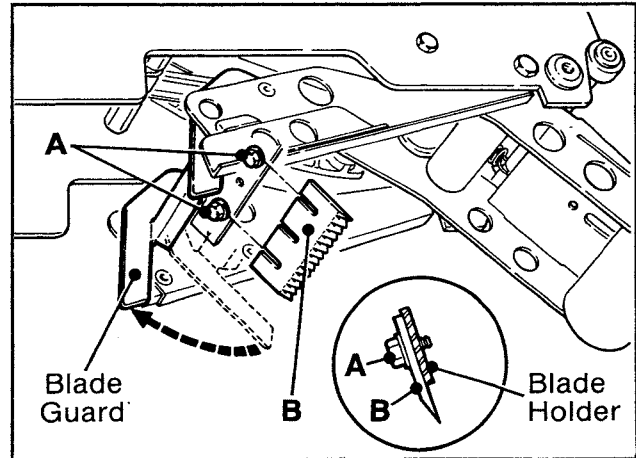

Figure 4-1 - Blade Replacement

Replacing Box Drive Belts

Figure 4-2

IT IS NOT NECESSARY TO REMOVE LOWER TAPING HEAD.

Install new belts and adjust belt tension as noted.

Case sealers are supplied with continuous belts. However, replacement belts are spliced (laced splicer) for easy installation.

To Remove Old Drive Belt:

1. Remove and retain center plate (A) and four screws.
2. Loosen, but do not remove lock nut (B).
3. Loosen tension screw (C) until all tension is removed.
4. Remove and retain side cover (D) and fasteners.
5. Cut thru old belt to remove and discard.
6. Place new belt over pulleys with laced splice at top. Insert splicing pin. Pin must not extend beyond edge of belt.
7. Refer to the adjustment section - "Box Drive Belts" and reset the belt tension as noted.
8. Replace the side cover and center plate, secure with original fasteners.

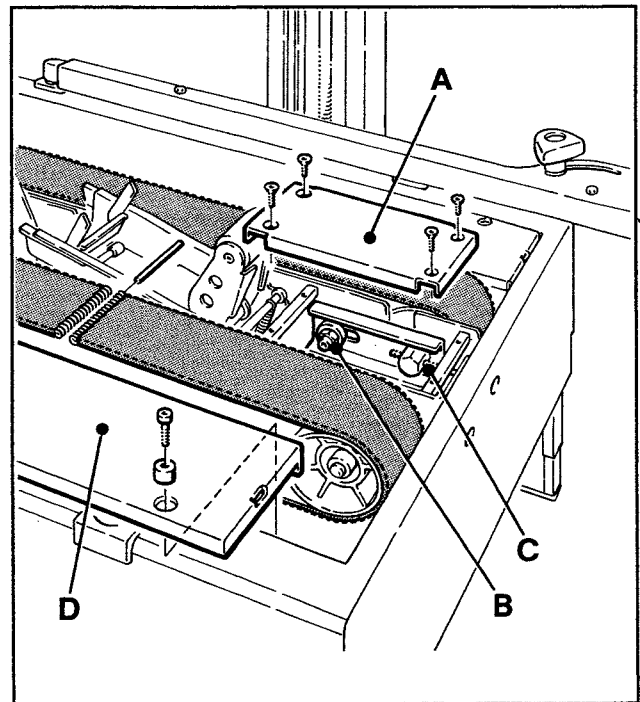

Figure 4-2 - Box Drive Replacement

⚠ WARNING - TURN OFF ELECTRICAL POWER AND DISCONNECT POWER CORD FROM ELECTRICAL SUPPLY BEFORE BEGINNING MAINTENANCE. IF POWER CORD IS NOT DISCONNECTED, SEVERE INJURY TO PERSONNEL COULD RESULT.

Cleaning of the Machine

Note - Never attempt to remove dirt by blowing it out with compressed air. This can cause the dirt to be blown inside the motor and onto sliding surfaces which may cause premature equipment wear. Never wash down or subject equipment to conditions causing moisture condensation on components. Serious equipment damage could result.

Regular slotted containers produce a great deal of **dust and paper chips** when processed or handled in equipment. If this dust is allowed to build up on machine components, it can cause **component wear and overheating** of drive motor. The dust build up can best be removed from the machine by a shop vacuum. Depending on the number and type of boxes sealed in the case sealer, this **cleaning** should be done approximately **once per month**. If the boxes sealed are dirty, or if the environment in which the machine operates is dusty, cleaning on a more frequent basis may be necessary. **Excessive dirt build up** that cannot be removed by vacuuming should be wiped off with a **damp cloth**.

Cut-Off Blade

Should tape **adhesive build-up** occur, carefully wipe clean with **oily cloth**.

Electrical Schematic

Figure 4-3 illustrates the electrical system of the case sealer. No adjustments to the electrical systems are required.

Circuit Breaker

The case sealer is equipped with a circuit breaker which trips the "On-Off" switch to tripped position. If circuit is overloaded and circuit breaker trips, wait 2 minutes, move to "Off", then turn "On". Located inside the electrical control box on the side of the main frame just below the conveyor bed, the circuit breaker has been pre-set at 2.3 Amps and requires no further maintenance.

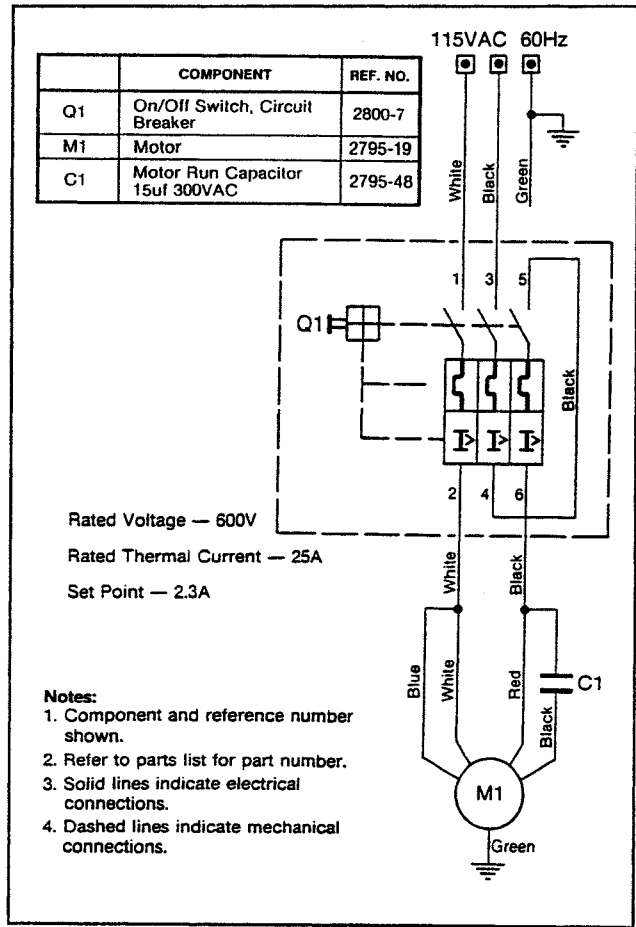

Figure 4-3

Maintenance (Continued)

⚠ WARNING - TURN OFF ELECTRICAL POWER AND DISCONNECT POWER CORD FROM ELECTRICAL SUPPLY BEFORE BEGINNING MAINTENANCE. IF POWER CORD IS NOT DISCONNECTED, SEVERE INJURY TO PERSONNEL COULD RESULT.

Lubrication - Mechanical

Like most other equipment, the case sealer must be properly lubricated to insure long, trouble/free service. Most of the machine bearings are permanently lubricated and sealed and do not need to be greased. The drive motor is also permanently lubricated and should not require additional lubrication.

Figures 4-4 and 4-5 illustrate the taping head and frame points which should be lubricated every 250 hours of operation. Lubricate the rotating and pivoting points, noted by the

arrows, (➡) with SAE #30 non-detergent oil. At the same time, a small amount of multipurpose grease should be applied to the end of each spring where the loop is secured at an eyelet, post, or hole, noted by the arrows (⇨).

Note - Wipe off excess oil and grease; it will attract dust and dirt which can cause premature equipment wear and jamming. Take care that oil and grease are not left on the surface of rollers around which tape is threaded, as it can contaminate the tape's adhesive.

Blade Oiler Pad

The taping heads are equipped with a blade oiler pad that has been pre-lubricated at the factory to provide a film of oil on the cut-off blade to reduce adhesive build-up. Apply SAE #30 non-detergent oil as needed. Saturate oiler pad.

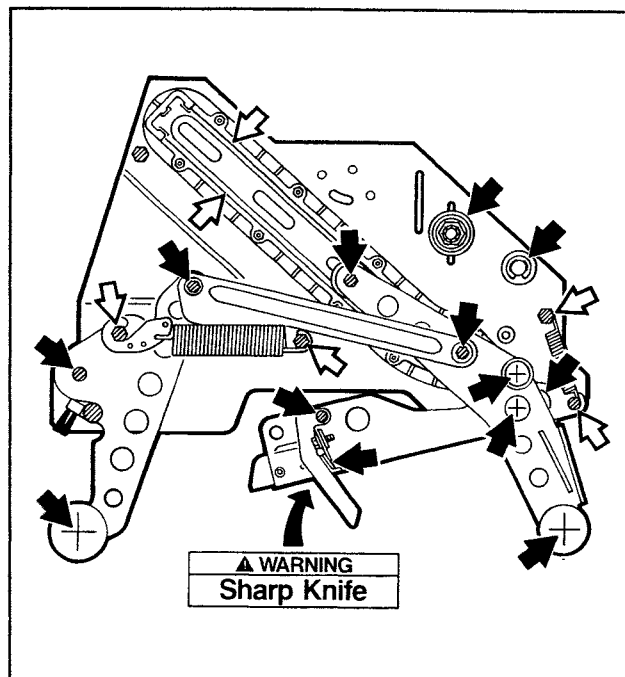

Figure 4-4 - Lubrication Points - Upper and Lower Taping Heads

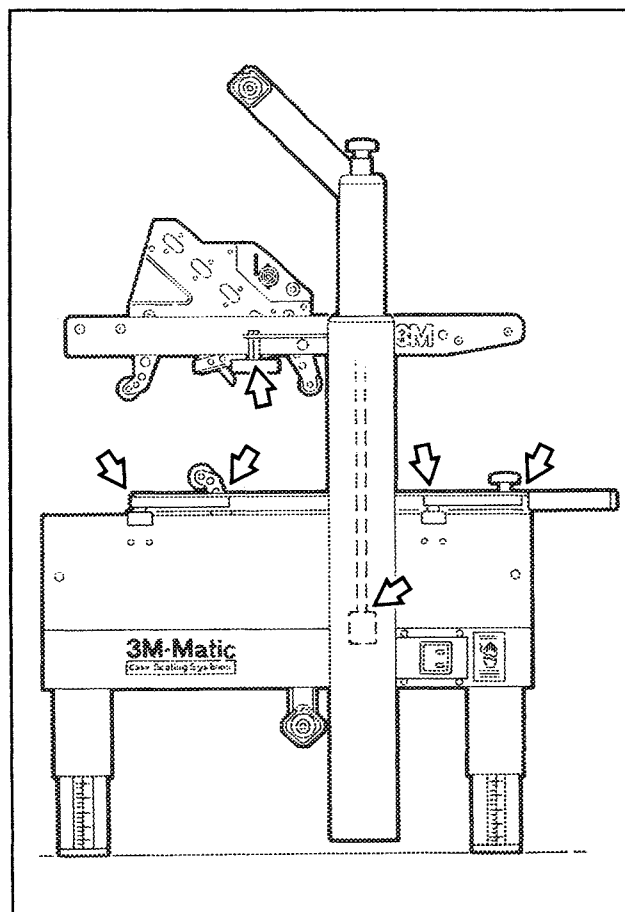

Figure 4-5 - Lubrication Points - Frame

Special Set-Up Procedure

Changing the Tape Leg Length From 2 3/4 to 2 Inches



WARNING - TURN OFF ELECTRICAL POWER SUPPLY AND DISCONNECT POWER CORD FROM ELECTRICAL SUPPLY BEFORE BEGINNING WORK ON THE CASE SEALER OR TAPING HEADS. IF POWER CORD IS NOT DISCONNECTED, SEVERE INJURY TO PERSONNEL COULD RESULT.

The following changes to the case sealer will allow the taping of boxes of 3.50 inches or 90 mm minimum height.

Case Sealer Figure 5-1A

1. Raise the upper head assembly (by turning crank handle counterclockwise). Remove and retain the two stop screws and washers from the normal position holes "A-A".
2. Remount and secure the stop in the lower position "A" using the top holes and original fasteners. Relocate both the right and left stop brackets.

Taping Heads



WARNING - USE CARE WHEN WORKING NEAR BLADES AS BLADES ARE EXTREMELY SHARP. IF CARE IS NOT TAKEN, SEVERE INJURY TO PERSONNEL COULD RESULT.

1. Loosen, but do not remove, the two retaining screws that secure the upper taping head shown in figure 5-1B.
2. Slide the head forward and lift straight up to remove it from the case sealer.
3. Lift the lower taping head, shown in figure 5-1C, straight up to remove it from the case sealer bed.

Figure 5-2

1. Remove and retain the two hex screws to remove the brush from the normal position "A" on the taping head frame.
2. Remount and secure the brush in position "A-A" (forward of the normal location) using the original fasteners.
3. Remove and retain the two flat head screws to remove the blade cut-off bracket extension in normal position "B".
4. Remount and secure the bracket extension in the forward position "B-B" using the original fasteners. Relocate both the right and left extensions.
5. Remove and retain the hex head screw and washer to remove the one-way tension roller assembly from slot "C" in the head frame.
6. Remount and secure tension roller assembly near top of slot "C-C" in frame using original fasteners.

Figure 5-3

The one-way tension roller position is adjustable to control the leading tape leg length. Moving this roller farther away from the box top surface will decrease the leading leg length. Moving it closer to the box top surface will increase the leading leg length.

Special Set-Up Procedure (Continued)

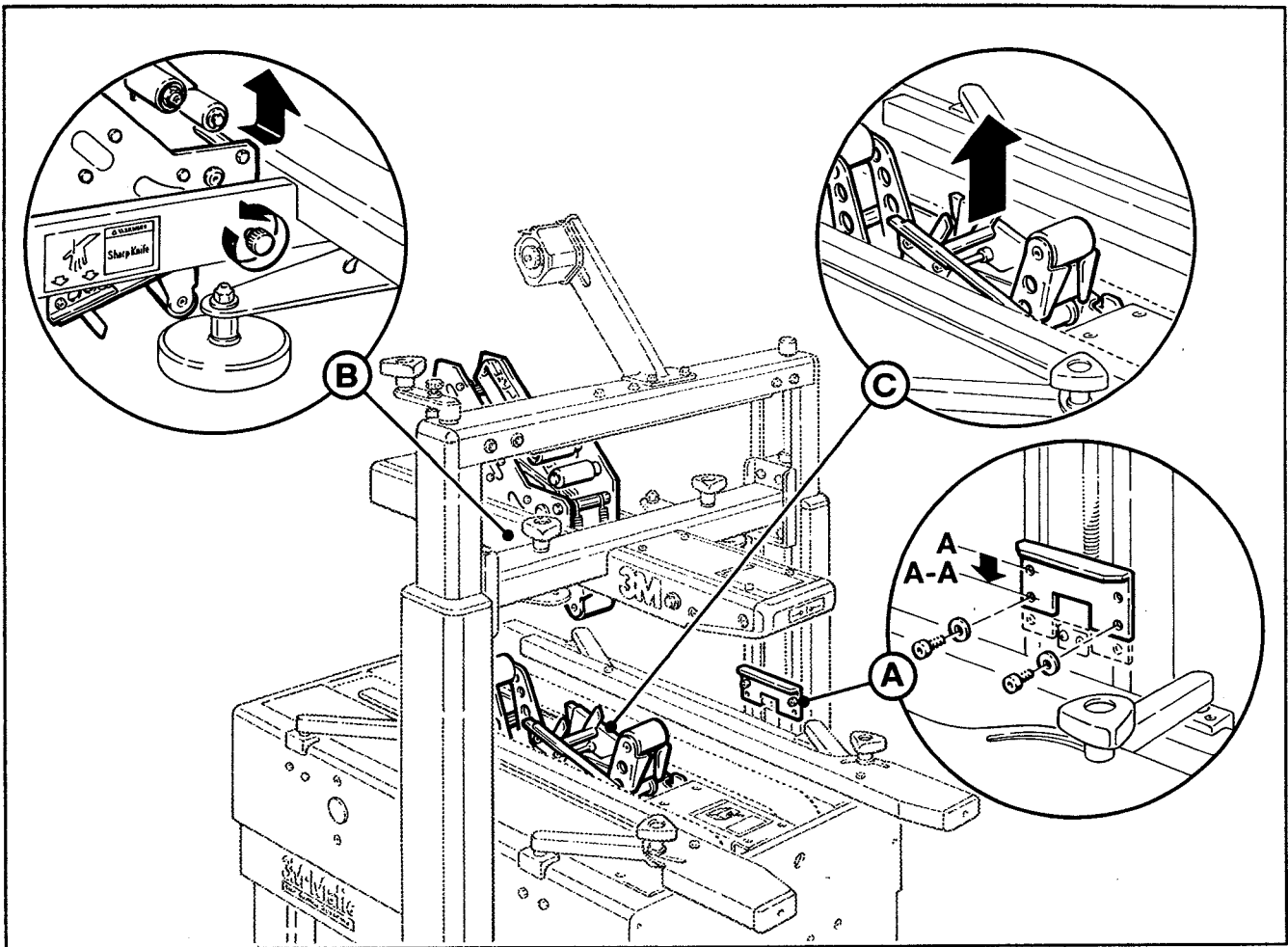

Figure 5-1 - Changes to Case Sealer

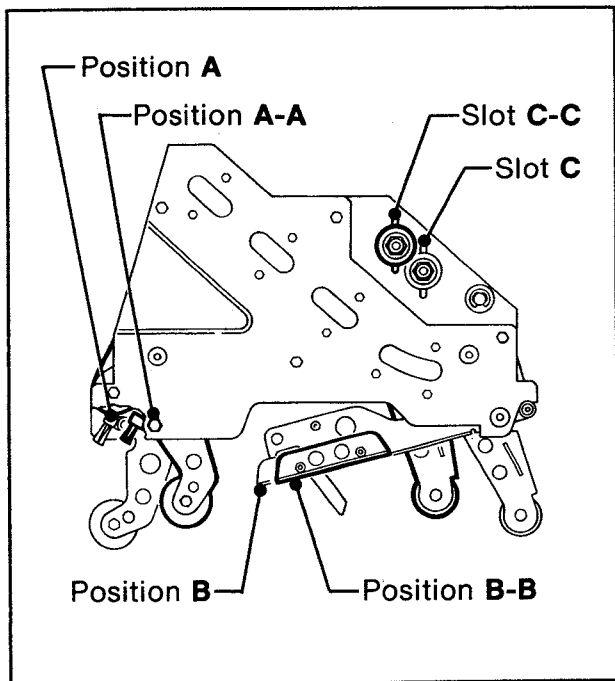

Figure 5-2 - Changes to Taping Head

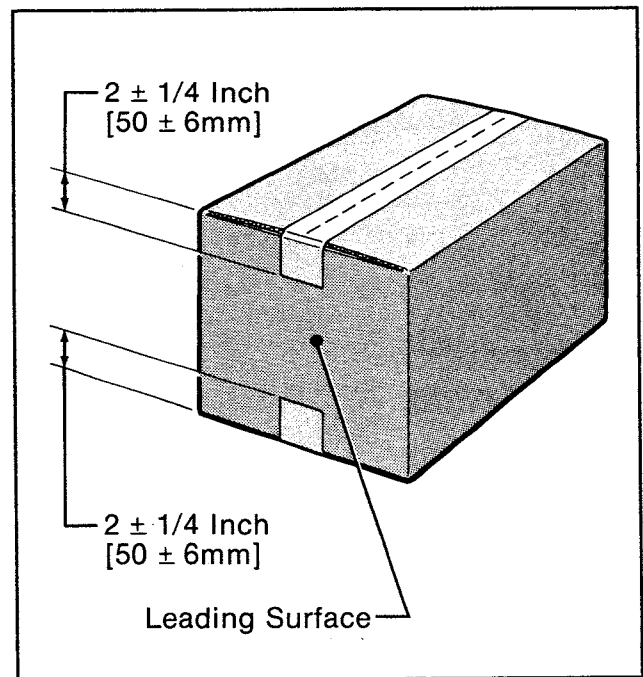

Figure 5-3 - Adjusting Tape Leg Length

Troubleshooting

Review Set-Up Procedure Section so that the operational components of the machine are understood. The Troubleshooting Guide lists some possible machine problems, causes and corrections.

Troubleshooting Guide

<u>Problem</u>	<u>Cause</u>	<u>Correction</u>
Drive belts do not convey boxes	Narrow boxes	Check machine specifications Boxes are narrower than recommended, causing slippage and premature belt wear
	Worn drive belts	Replace drive belts
	Top taping head does not apply enough pressure	Adjust the box height adjustment with the crank
	Top flap compression rollers in too tight	Readjust compression rollers
	Taping head applying spring holder missing	Replace spring holder
Drive belts do not turn	Taping head applying spring set too high	Reduce spring pressure
	Worn or missing friction rings	Replace friction rings
	Drive belt tension too low	Adjust belt tension
	Electrical disconnect	Check power and electrical plug
Upper and lower applying mechanisms interfere with each other	Circuit breaker not at correct setting	Set to correct current value
	Motor not turning	Evaluate problem and correct
Drive belts break	Machine's minimum height stop does not match tape head leg length setting	Check manual to make sure taping heads match machine setting.
Light boxes tip back on exit	Worn belt	Replace belt
Squeaking noise as boxes pass through machine	Upper ski down too far	Carefully adjust upper ski
	Dry compression rollers	Lubricate compression rollers
	Dry column bearings	Lubricate column bearings
Tape not centered on box seam	Defective column bearings	Replace column bearings
	Tape drum not centered	Reposition tape drum
	Centering guides not centered	Adjust centering guides
	Box flaps not of equal length	Check box specifications

(continued)

Troubleshooting (continued)

Troubleshooting Guide

Problem	Cause	Correction
The tape leg on the front of the case is too long	The tape is threaded incorrectly	The tape must go around the wrap roller before going around the one-way tension roller
	The tape tension is too low	Adjust the one-way tension roller
	The knurled roller drags	Check for adhesive build-up between the knurled roller and its shaft. Clean and lubricate shaft. Remove all lubricant from roller surfaces.
	Tape tracks to one side or drags on the support tabs of applying frame	Adjust the tape web alignment
	The one-way tension roller is not correctly positioned	Position the roller in its mounting slot so that the tape extends just beyond the center line of the applying roller
	Taping head is not set up properly	Check leg length adjustments
The blade does not cut tape or the tape end is jagged or shredded	The blade is dull and/or has broken teeth	Replace the blade
	Tape tension is insufficient	Increase tape tension by adjusting the one-way tension roller
	Adhesive has built up on the blade	Clean and adjust the blade
	The blade is not positioned properly	Make sure the blade is bottomed out against the mounting bolts
	The blade is dry	Lubricate the blade oiler pad on the blade guard
	The blade is in backwards	Mount the blade so that the beveled edge is away from the entrance end of the head
	One or both cutter springs are missing or stretched	Replace the defective spring(s)
	Tension roller surface is not fully contacting the taping head frame	Make sure one-way bearing is below the surface of the tension roller. If not, press bearing further into roller or replace roller.

(continued)

Troubleshooting (continued)

Troubleshooting Guide

Problem	Cause	Correction
Tape is tabbing on the trailing leg on the back of the box	There is excess tension on the tape drum assembly and/or the one-way tension roller assembly	Adjust the one-way tension roller and/or the tape drum assembly
	Rollers in the tape path do not rotate freely	Clean adhesive deposits from the surface, ends and shafts of the rollers. Then lubricate roller shafts. Remove all lubricant from roller surfaces.
	The blade is not cutting tape properly	Refer to tape cutting problems
	The tape is threaded incorrectly	Rethread the tape
The tape end does not stay in the application position in front of the applying roller	Applying mechanism spring has too little tension	Move spring hook to next tighter hole
	The tape is incorrectly threaded	Rethread the tape
	Flanged knurled roller overruns on return of applying mechanism to its rest position	Adjust tension roller position in mounting slot to lengthen tape leg
	Applying roller overruns on return of applying mechanism to its rest position	There should be a slight drag when rotating the applying roller. If not, check friction springs and/or friction pins and replace if necessary.
	The one-way tension roller is not correctly positioned	Position roller in its mounting slot so that tape end extends beyond center line of applying roller
The one-way tension roller is defective	Replace the one-way tension roller	

Replacement Parts And Service Information

Spare Parts

It is suggested that the following spare parts be ordered and kept on hand:

Qty.	Ref. No.	Part Number	Description
1	2880-15	78-8057-6179-4	Roller - Applying
1	2881-5	78-8057-6178-6	Roller - Buffing
1	2881-10	78-8070-1274-1	Spring - Upper Extension
1	2883-2	78-8017-9173-8	Blade - 2.56 Inch/65 mm
2	2883-12	78-8052-6602-6	Spring - Cutter
1	2886-10	78-8070-1273-3	Spring - Lower Extension
2	2812-38	78-8070-1531-4	Belt - Drive W/Hook

Label Kit

A label kit, part number 78-8070-1422-6, is available as a stock item. It contains all the safety labels used on the 200a Adjustable Case Sealer.

Tool Kit

A tool kit, part number 78-8060-8476-6, is available as a stock item. The kit contains the necessary open end and hex socket wrenches for use with the metric fasteners on the case sealer. The threading tool, part number 78-8076-4726-4, contained in above kit is also available as a replacement stock item. Refer to "How To Order Replacement Parts" for ordering information.

How To Order Replacement Parts

1. Order parts by part number, part name, machine number, type number and part quantity required. A parts order form is provided at the back of the manual.

<p>Minimum billing on parts orders will be \$10.00. Replacement part prices available on request.</p>
--

2. Replacement parts and part prices available direct from:

**3M/Tape Dispenser Parts
241 Venture Drive
Amery, WI 54001-1325**

Note - Outside the U.S. contact the local 3M subsidiary for parts order information.

Repair Service

Refer to the first page of this instruction manual "Service Instructions" for information on repair service.

Options/Accessories

For additional information on the options/accessories listed below contact your 3M Representative.

<u>Part Number</u>	<u>Option/Accessory</u>
78-8052-6553-1	Box Hold Down Attachment, Model 18500
78-8060-7405-6	Caster Kit Attachment
78-8069-3924-1	Conveyor Extension Attachment
78-8069-3926-6	Low Tape Sensor Kit
78-8059-3911-8	AccuGlide II STD Taping Head (Upper)
78-8069-3912-6	AccuGlide II STD Taping HEad (Lower)

Replacement Parts Illustrations and Parts Lists
200a Adjustable Case Sealer, Type 19000
Taping Head Assemblies

1. Refer to **Taping Head Assemblies** figure to find all the parts illustrations identified by figure numbers.

2. Refer to the figure or figures to determine the **individual parts** required and the parts reference number.

- 3 . The replacement parts list, that follows each illustration, includes the **part number** and **part description** for the parts in that illustration.

Note - The complete description has been included for standard **fasteners** and some **commercially available components**. This has been done to allow obtaining these standard parts locally, should the customer elect to do so.

4. Refer to page 32 - "**Replacement Parts and Service Information**" of this manual for replacement parts ordering information.

THIS PAGE IS BLANK

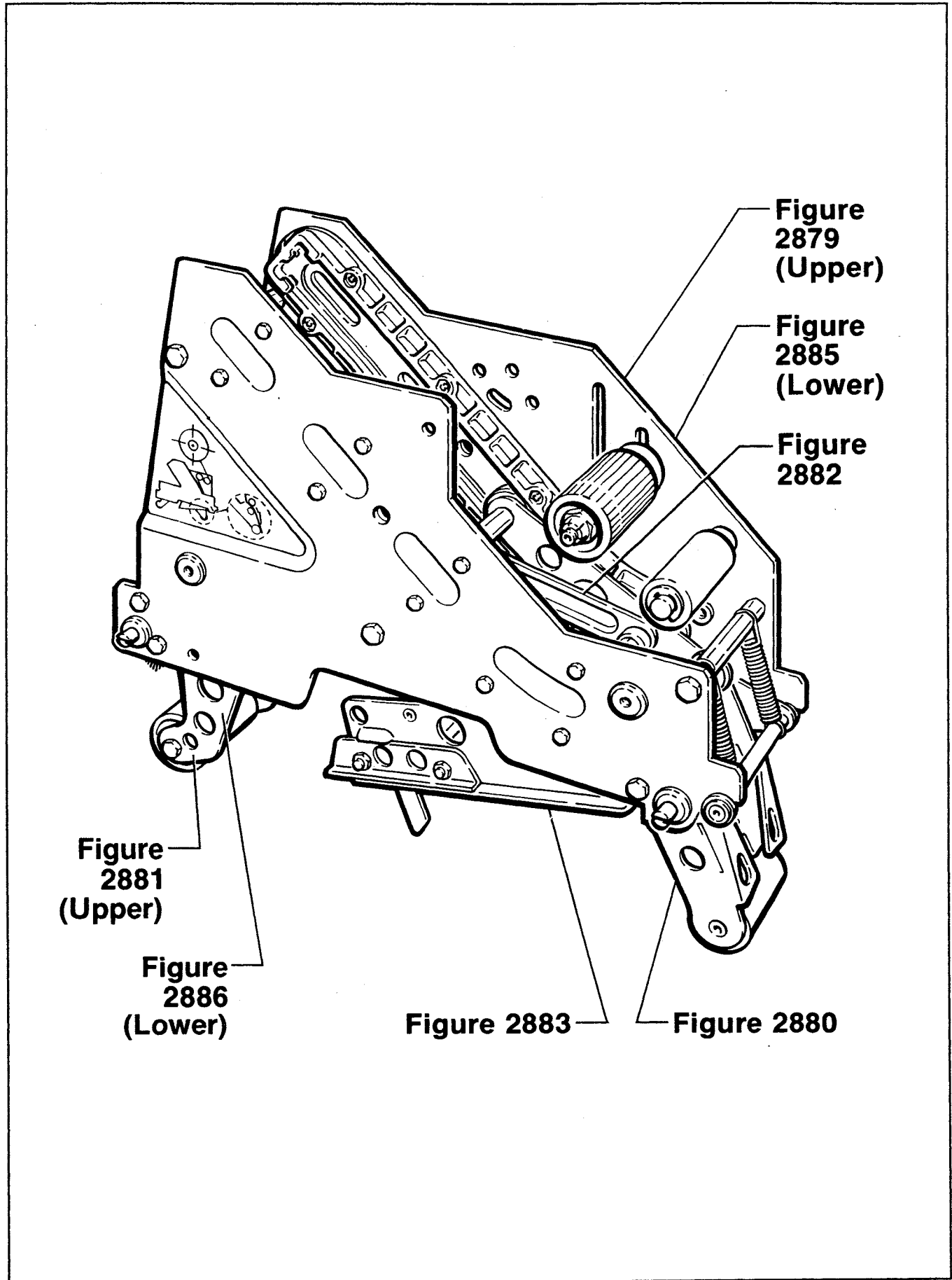

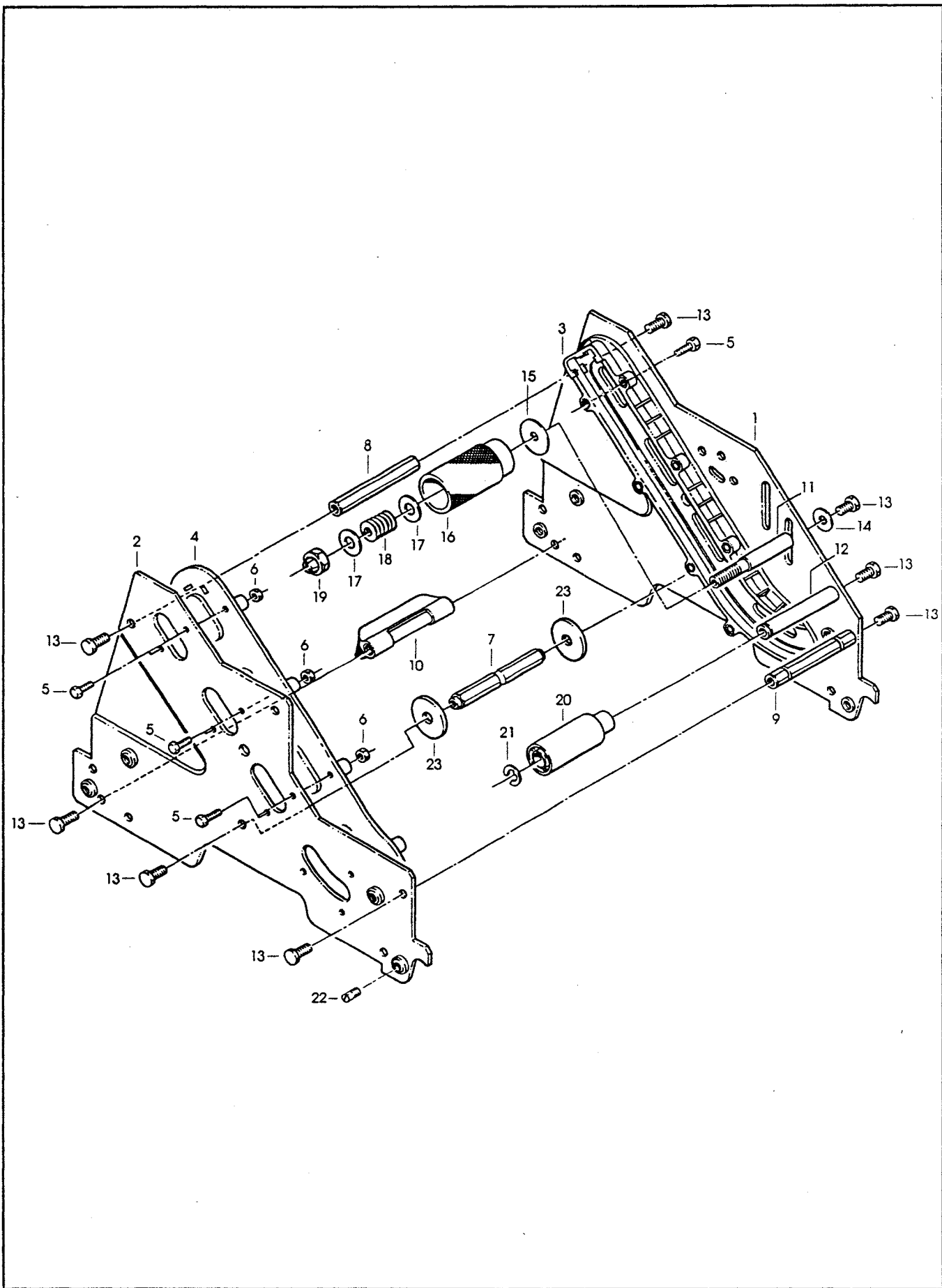

Figure 2879 Upper

Figure 2879 Upper

Ref. No.	3M Part No.	Description
2879-1	78-8070-1386-3	Frame - Tape Mount Upper Assembly
2879-2	78-8070-1387-1	Frame - Front Upper Assembly
2879-3	78-8068-4143-9	Guide - R/H
2879-4	78-8068-4144-7	Guide - L/H
2879-5	83-0002-7336-3	Screw - Hex Hd M4 x 14
2879-6	78-8010-7416-8	Nut - Hex M4
2879-7	78-8070-1251-9	Spacer - Spring
2879-8	78-8052-6559-8	Spacer - Upper
2879-9	78-8052-6560-6	Spacer - Front
2879-10	78-8060-7936-0	Brush Assembly
2879-11	78-8052-6564-8	Shaft - Tension Roller
2879-12	78-8052-6568-9	Shaft - Wrap Roller
2879-13	26-1003-5829-5	Screw - Hex Hd M6 x 12
2879-14	78-8042-2919-9	Washer - Triple, M6
2879-15	78-8070-1268-3	Washer - Roll Back Up
2879-16	78-8052-6565-5	Roller - Top Tension
2879-17	78-8052-6566-3	Washer - Friction
2879-18	78-8052-6567-1	Spring - Compression
2879-19	78-8017-9077-1	Nut - Self Locking M10 x 1
2879-20	78-8052-6569-7	Roller - Wrap
2879-21	26-1000-1613-3	Ring - Retaining 10DIN6799
2879-22	78-8076-4500-3	Stud - Mounting
2879-23	78-8076-5242-1	Stop - Cut Off Frame

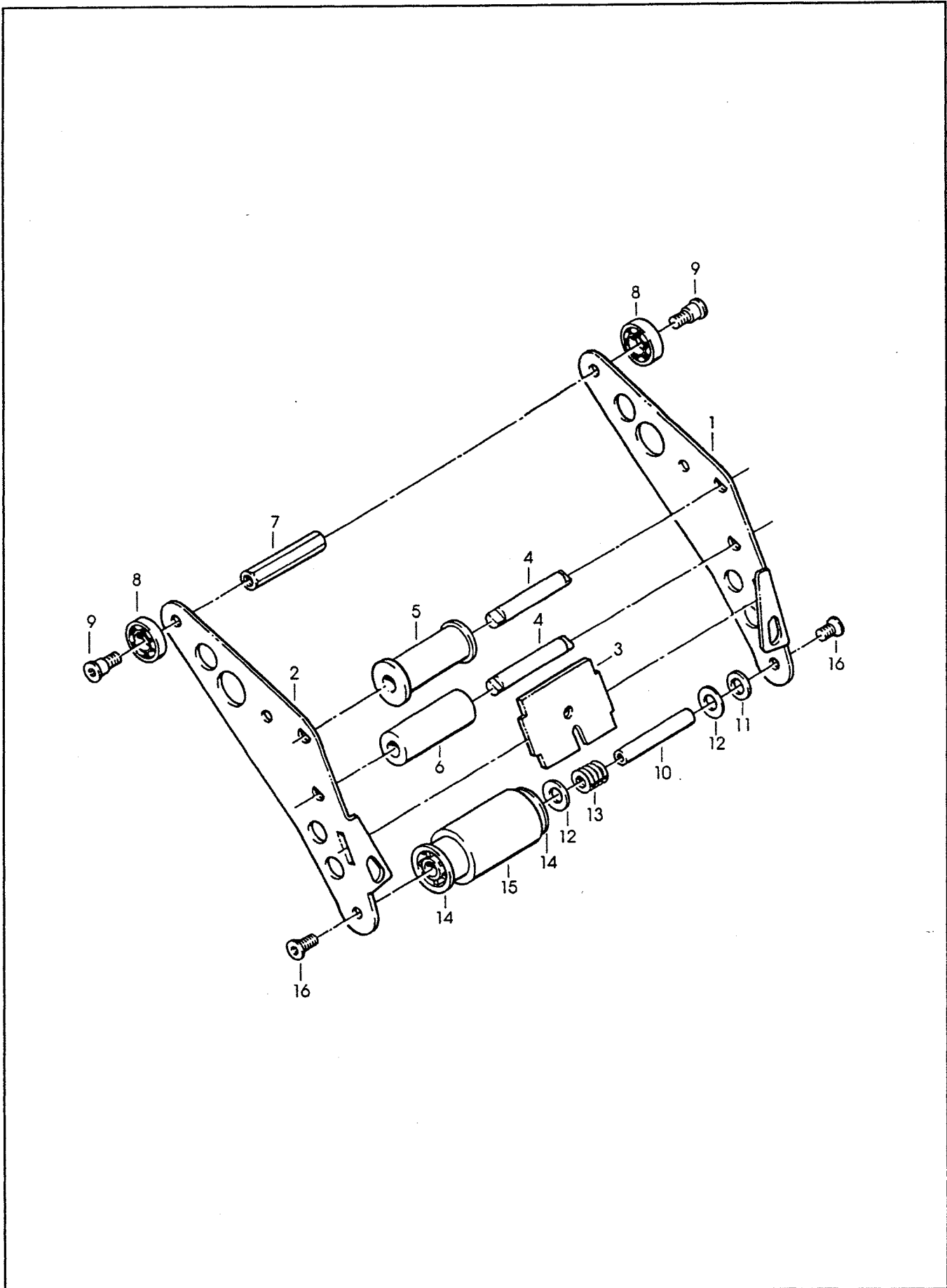

Figure 2880

Figure 2880

Ref. No.	3M Part No.	Description
2880-1	78-8070-1206-3	Arm - Applying R/H
2880-2	78-8070-1207-1	Arm - Applying L/H
2880-3	78-8070-1221-2	Plate - Tape
2880-4	78-8070-1309-5	Shaft - Roller
2880-5	78-8070-1367-3	Roller - Knurled Assembly
2880-6	78-8070-1266-7	Roller - Wrap
2880-7	78-8052-6580-4	Spacer - Rear
2880-8	78-8017-9082-1	Bearing - Special 30 mm
2880-9	78-8017-9106-8	Screw - Bearing Shoulder
2880-10	78-8052-6575-4	Shaft - Roller
2880-11	78-8017-9074-8	Washer - Nylon 15 mm
2880-12	78-8052-6566-3	Washer - Friction
2880-13	78-8052-6567-1	Spring - Compression
2880-14	78-8060-8395-8	Bushing - Applying Roller
2880-15	78-8057-6179-4	Roller - Applying NM
2880-16	26-1005-4759-0	Screw - Flat Hd M6 x 12

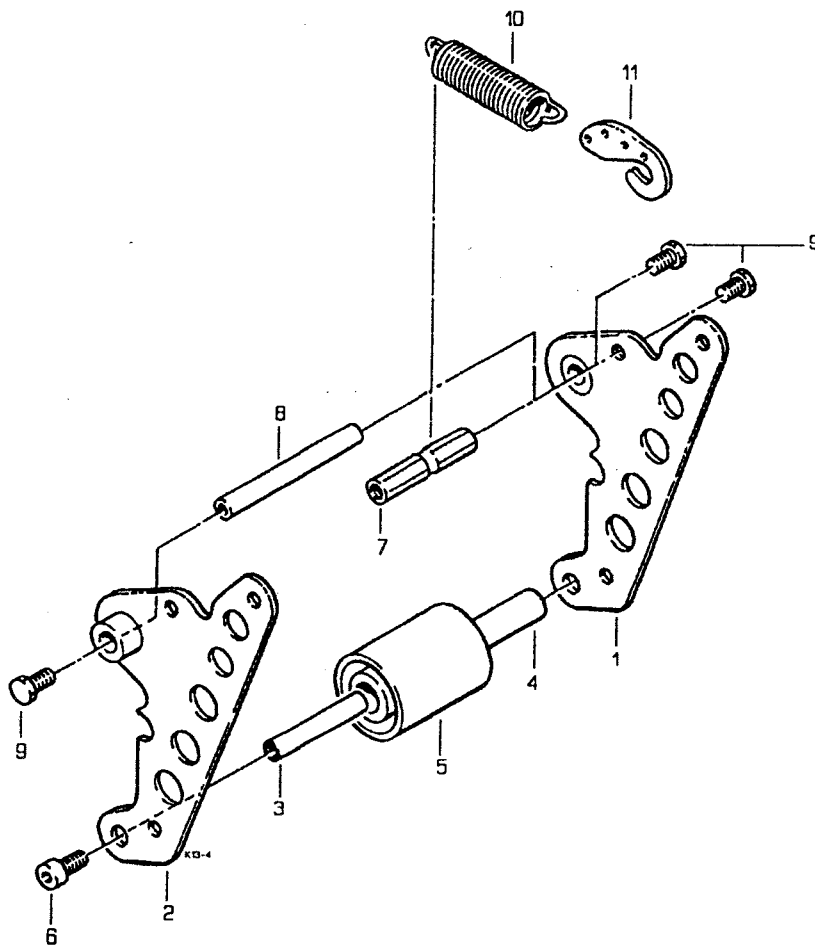

Figure 2881 Upper

Figure 2881 Upper

Ref. No.	3M Part No.	Description
2881-1	78-8070-1392-1	Buffing Arm Sub Assembly
2881-2	78-8070-1391-3	Buffing Arm Sub Assembly
2881-3	78-8052-6575-4	Shaft - Roller
2881-4	78-8052-6586-1	Bushing - Buffing Roller
2881-5	78-8057-6178-6	Roller - Buffing NM
2881-6	78-8076-4503-7	Screw - M6 x 12
2881-7	78-8070-1220-4	Spacer - Spring
2881-8	78-8017-9109-2	Shaft - 10 x 90 mm
2881-9	26-1003-5828-7	Screw - Hex Hd M6 x 12
2881-10	78-8070-1274-1	Spring - Upper (Silver)
2881-11	78-8070-1244-4	Holder - Spring

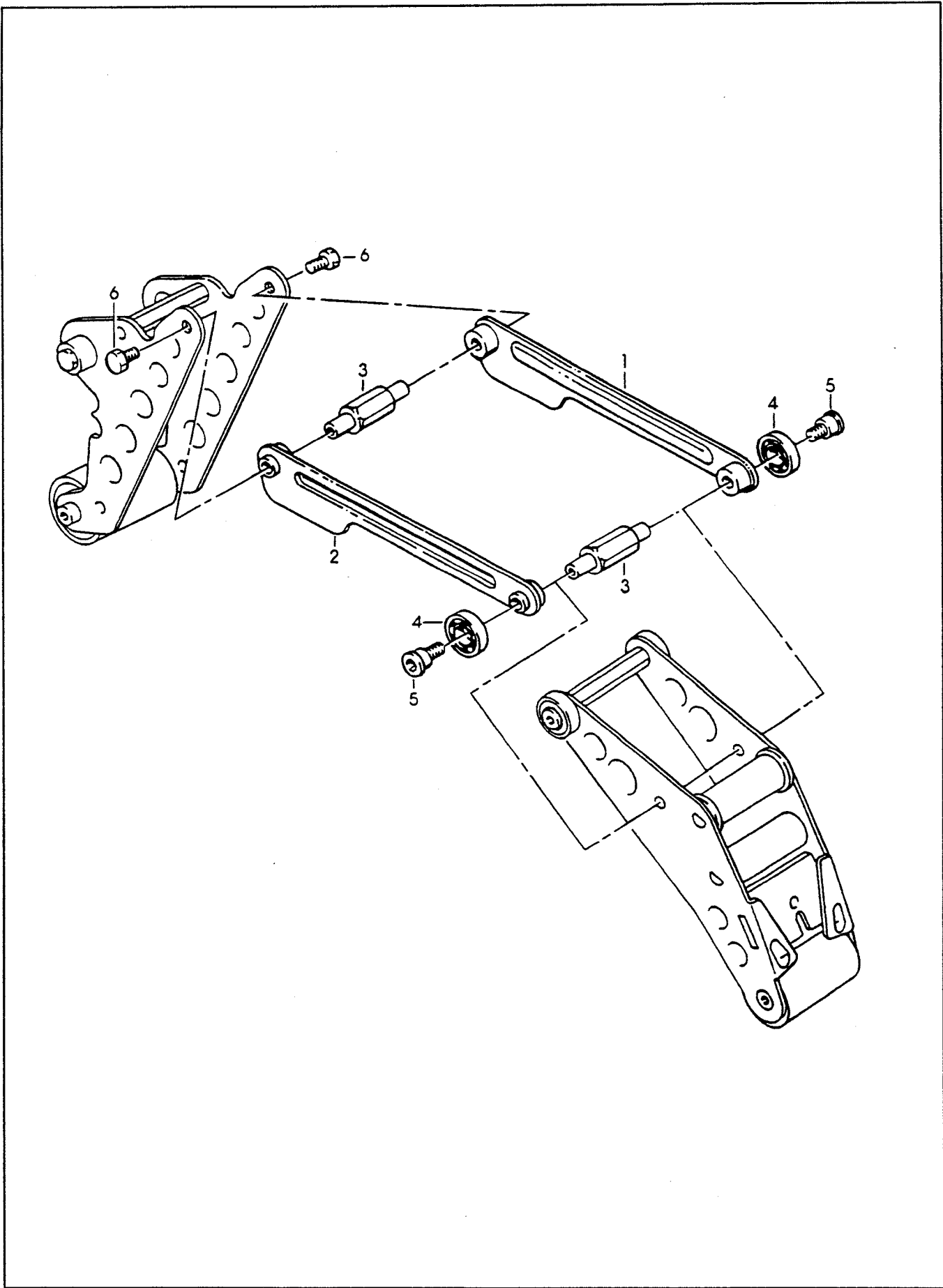

Figure 2882

Figure 2882

Ref. No.	3M Part No.	Description
2882-1	78-8070-1388-9	Link - Arm Bushing Assembly
2882-2	78-8070-1389-7	Link - Arm Bushing Assembly
2882-3	78-8070-1271-7	Shaft - Pivot
2882-4	78-8017-9082-1	Bearing - Special 30 mm
2882-5	78-8017-9106-8	Screw - Bearing Shoulder
2882-6	78-8010-7163-6	Screw - Hex Hd M5 x 10

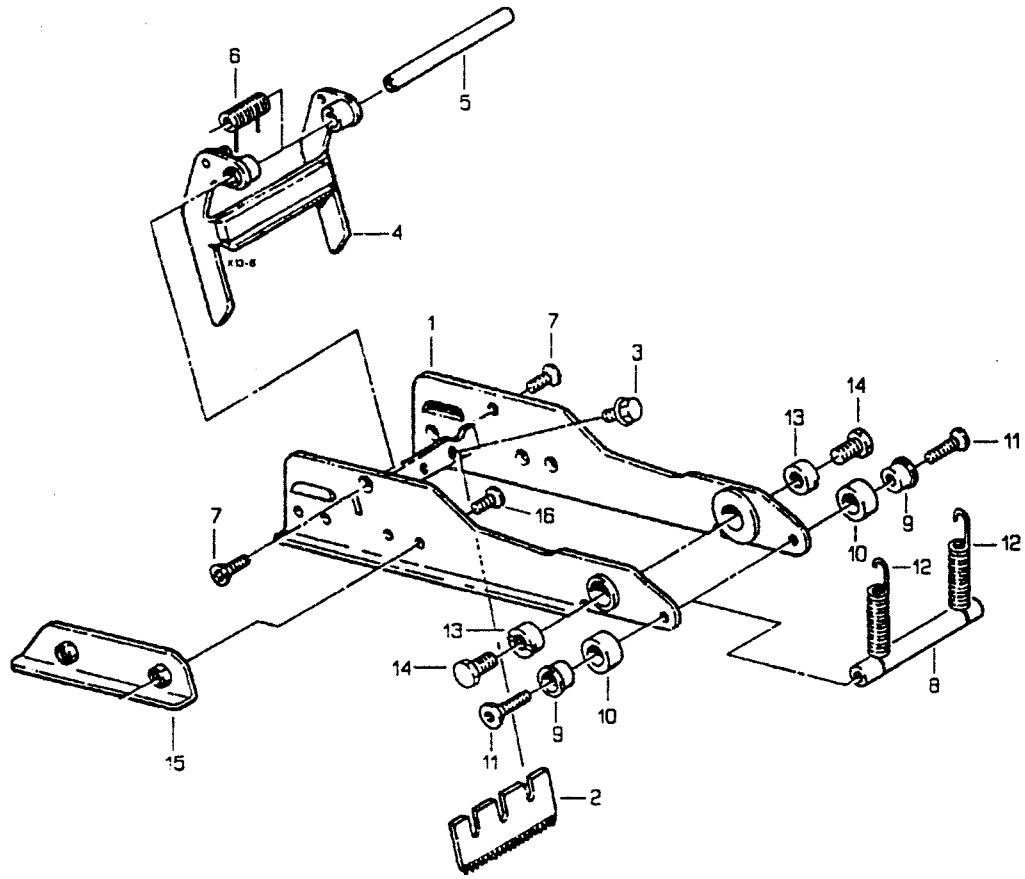

Figure 2883

Figure 2883

Part No.	3M Part No.	Description
2883-1	78-8070-1217-0	Frame - Cut-Off Weldment
2883-2	78-8017-9173-8	Blade - 2.56 Inch/65 mm
2883-3	26-1003-8596-7	Screw - Hex Hd M5 x 8 W/Ext. Tooth Washer
2883-4	78-8070-1371-5	Guard - Blade Assembly
2883-5	78-8052-6597-8	Shaft - Blade Guard
2883-6	78-8070-1390-5	Spring - Tension
2883-7	26-1005-4757-4	Screw - Flat Hd M4 x 10
2883-8	78-8017-9135-7	Shaft - Spacer
2883-9	78-8052-6600-0	Spacer
2883-10	78-8070-1269-1	Bumper
2883-11	26-1005-4758-2	Screw - Flat Hd M5 x 20
2883-12	78-8052-6602-6	Spring - Cutter
2883-13	78-8017-9132-4	Pivot - Cutter Lever
2883-14	26-1003-5828-7	Screw - Hex Hd M6 x 10
2883-15	78-8070-1216-2	Slide - Extension
2883-16	26-1008-6574-5	Screw - Phillips FH M4 x 10

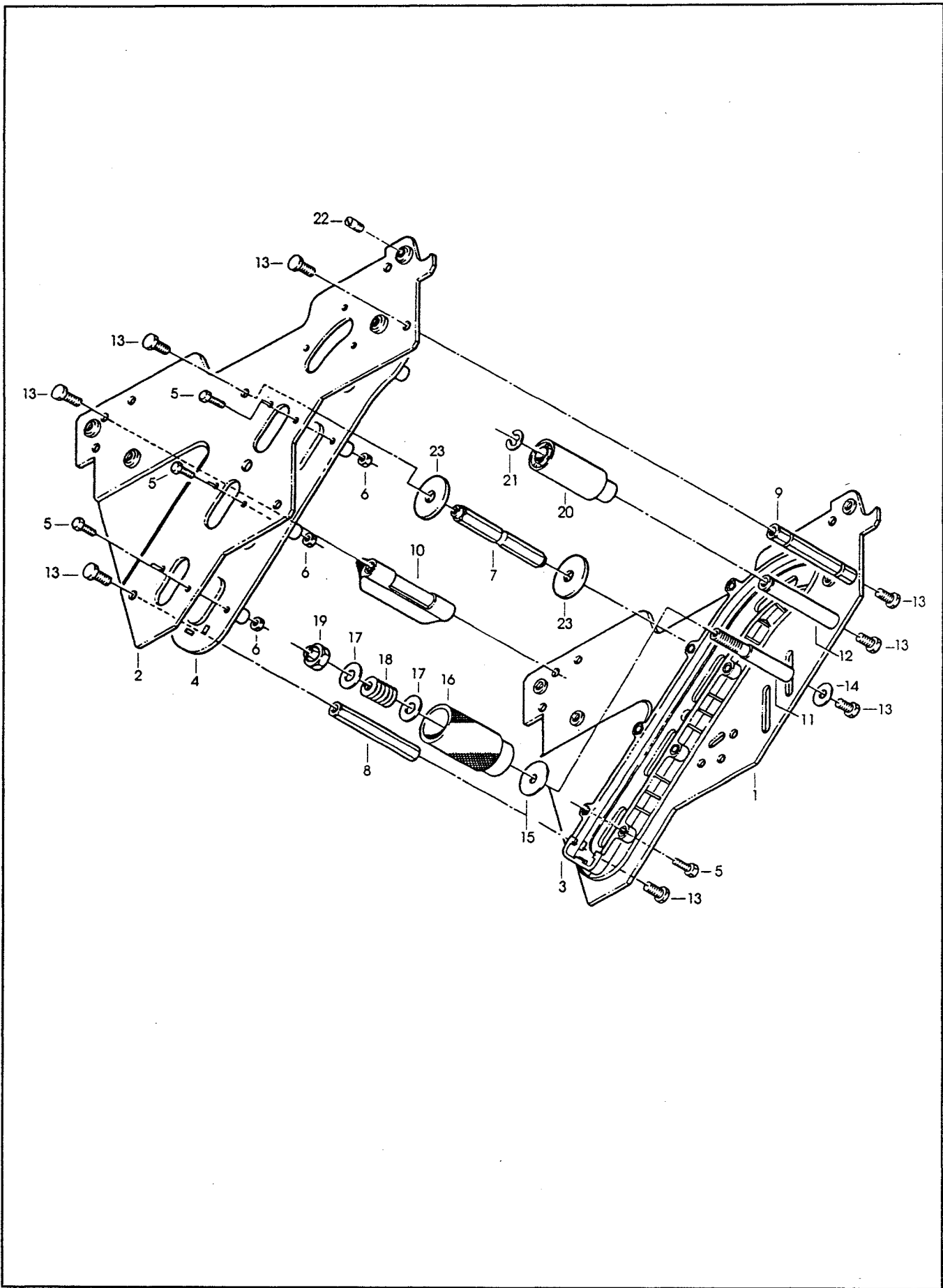

Figure 2885 Lower

Figure 2885 Lower

Ref. No.	3M Part No.	Description
2885-1	78-8070-1370-7	Frame - Front Lower Assembly
2885-2	78-8070-1369-9	Frame - Tape Mount Lower Assembly
2885-3	78-8068-4143-9	Guide - R/H
2885-4	78-8068-4144-7	Guide - L/H
2885-5	83-0002-7336-3	Screw - Hex Hd M4 x 14
2885-6	78-8010-7416-8	Nut - Hex M4
2885-7	78-8070-1251-9	Spacer - Spring
2885-8	78-8052-6559-8	Spacer - Upper
2885-9	78-8052-6560-6	Spacer - Front
2885-10	78-8060-7936-0	Brush Assembly
2885-11	78-8052-6564-8	Shaft - Tension Roller
2885-12	78-8052-6568-9	Shaft - Wrap Roller
2885-13	26-1003-5829-5	Screw - Hex Hd M6 x 12
2885-14	78-8042-2919-9	Washer - Triple M6
2885-15	78-8070-1268-3	Washer - Roll Back Up
2885-16	78-8052-6606-7	Roller - Tension Bottom
2885-17	78-8052-6566-3	Washer - Friction
2885-18	78-8052-6567-1	Spring - Compression
2885-19	78-8017-9077-1	Nut - Self Locking M10 x 1
2885-20	78-8052-6569-7	Roller - Wrap
2885-21	26-1000-1613-3	Ring - Retaining 1DIN6799
2885-22	78-8076-4500-3	Stud - Mounting
2885-23	78-8076-5242-1	Stop - Cut Off Frame

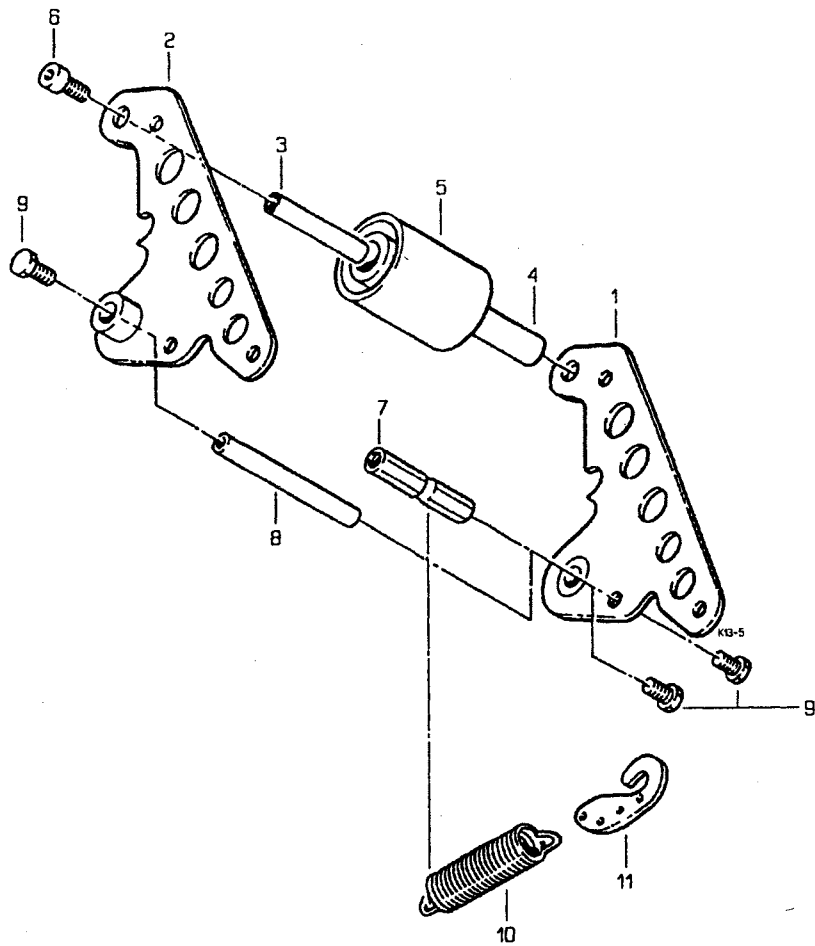

Figure 2886 Lower

Figure 2886 Lower

Ref. No.	3M Part No.	Description
2886-1	78-8070-1391-3	Buffing Arm Sub Assembly
2886-2	78-8070-1392-1	Buffing Arm Sub Assembly
2886-3	78-8052-6575-4	Shaft - Roller
2886-4	78-8052-6586-1	Bushing - Buffing Roller
2886-5	78-8057-6178-6	Roller - Buffing NM
2886-6	78-8076-4503-7	Screw - M6 x 12
2886-7	78-8070-1220-4	Spacer - Spring
2886-8	78-8017-9109-2	Shaft - 10 x 90 mm
2886-9	26-1003-5828-7	Screw - Hex Hd M6 x 12
2886-10	78-8070-1273-3	Spring - Lower (Black)
2886-11	78-8070-1244-4	Holder - Spring

THIS PAGE IS BLANK

**Replacement Parts Illustrations and Parts List
200a Adjustable Case Sealer, Type 19000
Frame Assemblies**

1. Refer to **Frame Assemblies figure** to find all parts illustrations identified by **figure numbers**.

2. Refer to the figure or figures to determine the **individual parts** required and the **parts reference number**.

3. The **replacement parts list**, that follows each illustration, includes the **part number** and **part description** for the parts in the illustration.

Note - The complete description has been included for standard **fasteners** and some **commercially available components**. This has been done to allow obtaining these standard parts locally, should the customer elect to do so.

4. Refer to page 32 - "**Replacement Parts and Service Information**" of this manual for replacement parts ordering information.

THIS PAGE IS BLANK

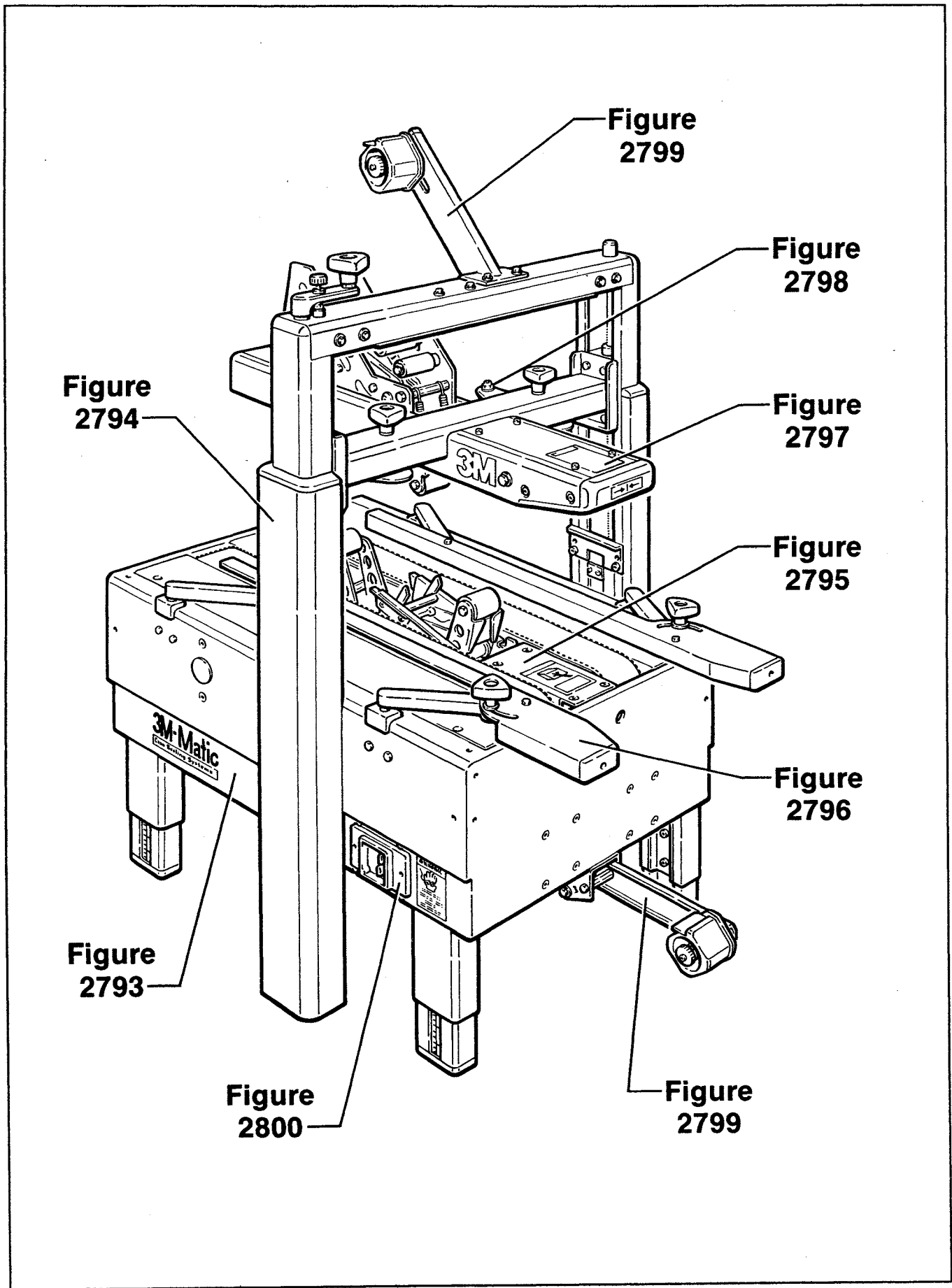

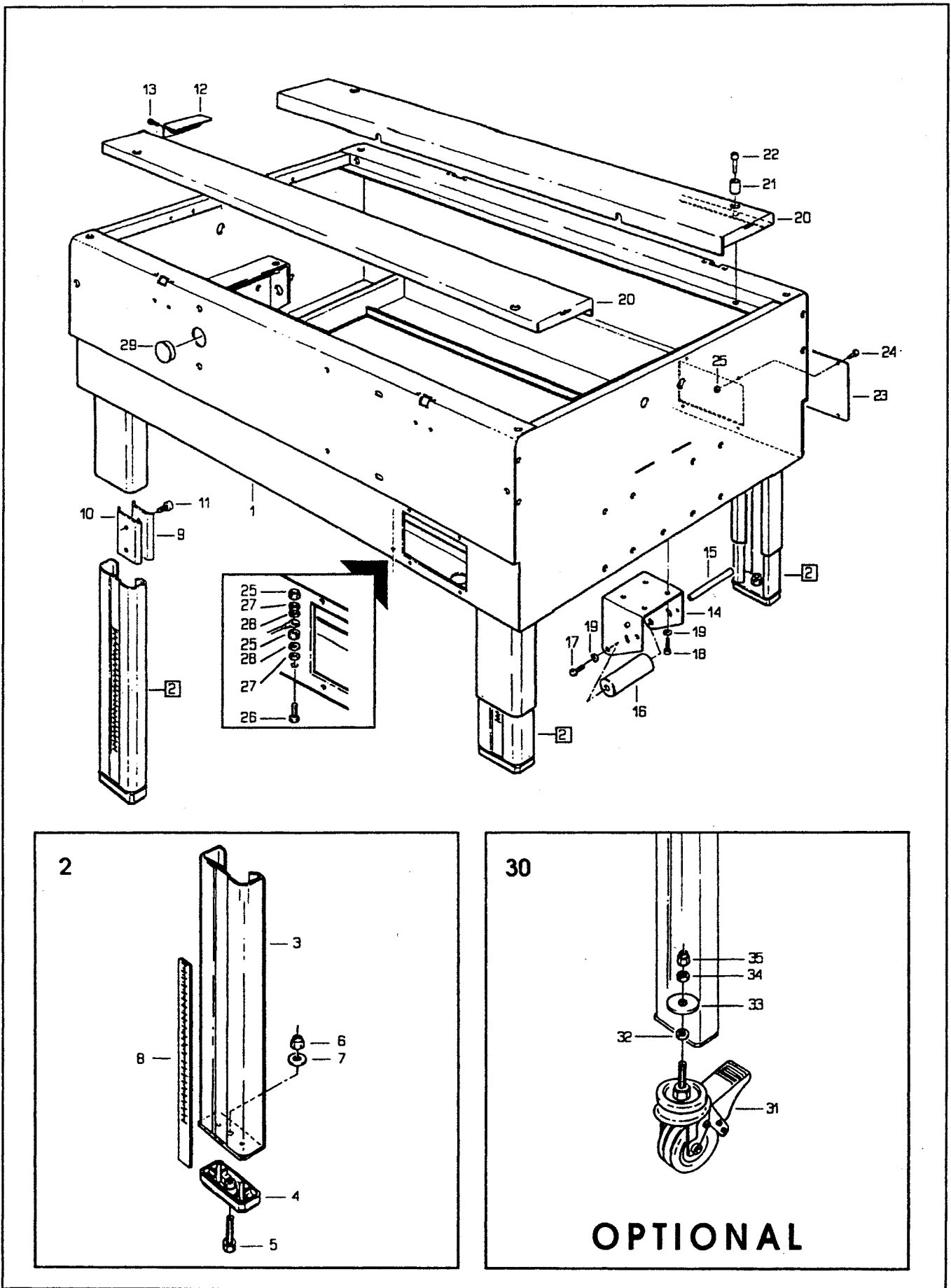

Figure 2793

Figure 2793

Ref. No.	3M Part No.	Description
2793-1	78-8060-8477-4	Bed - Conveyor
2793-2	78-8060-8478-2	Leg Assembly - Inner
2793-3	78-8060-8479-0	Leg - Inner
2793-4	78-8060-8480-8	Pad - Foot
2793-5	78-8055-0867-4	Screw - Hex Hd M8 x 30
2793-6	78-8017-9313-0	Nut - Self Locking M8
2793-7	26-1004-5507-5	Washer M8
2793-8	78-8060-8481-6	Label - Height
2793-9	78-8052-6676-0	Clamp - Outer
2793-10	78-8052-6677-8	Clamp - Inner
2793-11	26-1003-7963-0	Screw - Soc Hd M8 x 16
2793-12	78-8060-8482-4	Plate - Protection
2793-13	26-1003-7948-1	Screw - Soc Hd Hex Soc M5 x 10
2793-14	78-8060-8483-2	Support - Outboard Roll Mount
2793-15	78-8060-8484-0	Shaft - Roller
2793-16	78-8060-8485-7	Roller
2793-17	78-8032-0375-7	Screw - Hex Hd M6 x 16, Metric
2793-18	26-1003-7957-2	Screw - Soc Hd Hex Hd M6 x 16
2793-19	26-1000-0010-3	Washer - Flat M6
2793-20	78-8070-1579-3	Conveyor Bed - Plane
2793-21	78-8060-8486-5	Bushing
2793-22	78-8010-7211-3	Screw - Soc Hd M6 x 25
2793-23	78-8060-8487-3	Cover - Switch
2793-24	78-8060-8087-1	Screw - M5 x 10, Metric
2793-25	78-8010-7417-6	Nut - Hex Stl. M5, Metric
2793-26	78-8060-8488-1	Screw - Hex Hd M5 x 20
2793-27	78-8046-8217-3	Washer - Special
2793-28	78-8005-5741-1	Washer - Plain M5, Metric
2793-29	78-8076-4701-7	Cap /28
2793-30	78-8060-8060-8	Caster Assembly /80
2793-31	78-8060-8061-6	Caster - /80
2793-32	78-8060-8124-2	Spacer - Caster
2793-33	78-8060-7699-4	Washer - 12-45, 5X4
2793-34	78-8017-9059-9	Washer - Flat for M12 Screw
2793-35	78-8060-7532-7	Nut - M12 Self Locking

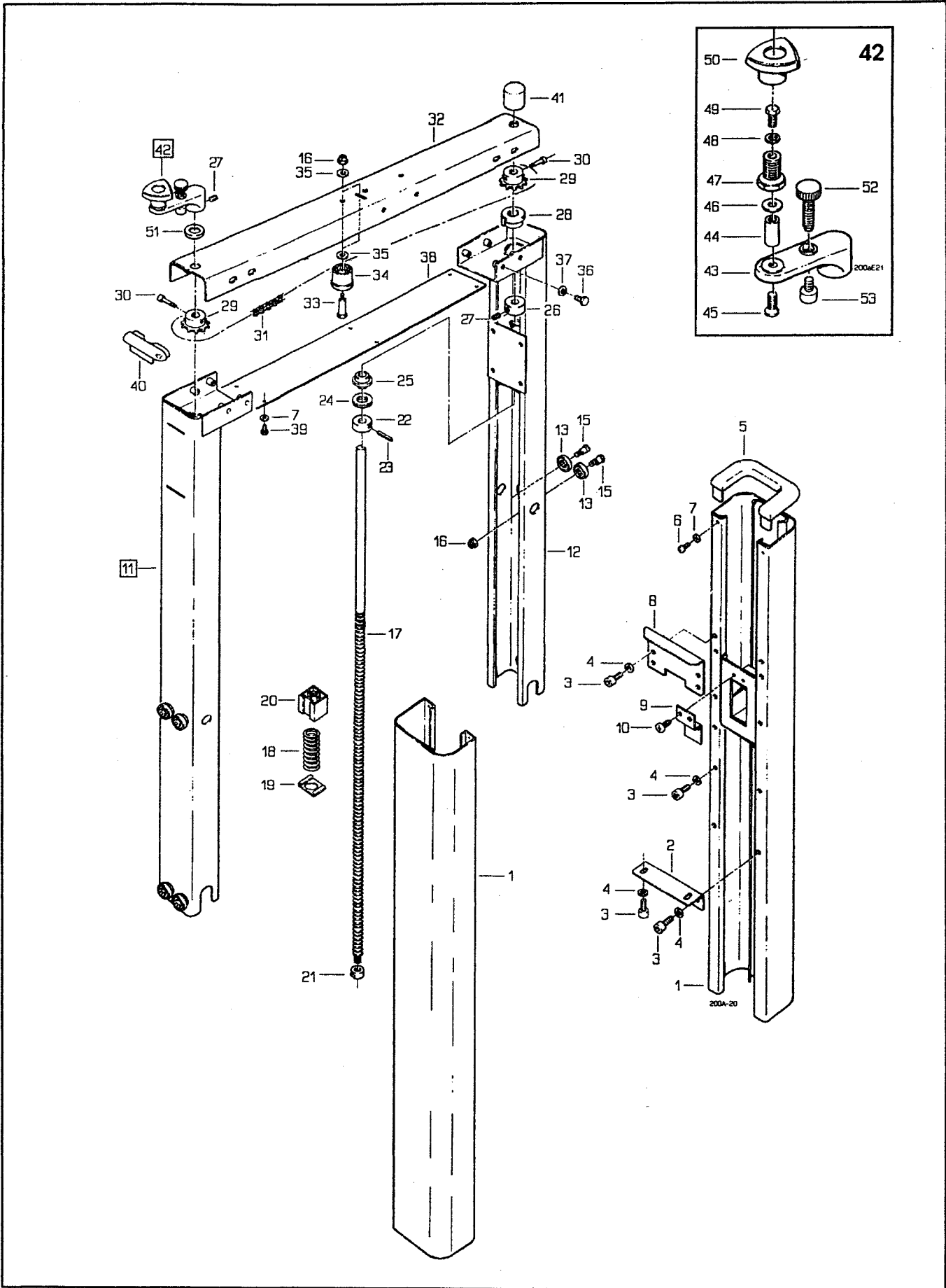

Figure 2794

Figure 2794

Ref. No.	3M Part No.	Description
2794-1	78-8060-8489-9	Column - Outer
2794-2	78-8060-8490-7	Plate - Column Mounting
2794-3	26-1003-7963-0	Screw - Soc Hd M8 x 16
2794-4	78-8017-9318-9	Washer - Plain 8 mm, Metric
2794-5	78-8060-8491-5	Cap - Column
2794-6	26-1002-4955-1	Screw - Self Tap 8P x 13
2794-7	78-8005-5740-3	Washer - Plain 4 mm, Metric
2794-8	78-8060-8492-3	Stop - Height
2794-9	78-8060-8493-1	Plate - Nut Stop
2794-10	78-8060-8087-1	Screw - M5 x 10, Metric
2794-11	78-8060-8494-9	Column Assembly - Inner
2794-12	78-8060-8495-6	Column - Inner
2794-13	78-8054-8617-8	Bearing - Special
2794-15	78-8054-8589-9	Screw - Special
2794-16	26-1003-6916-9	Nut - M6 Locking Plastic Insert
2794-17	78-8060-8496-4	Screw - Lead
2794-18	78-8054-8969-3	Spring
2794-19	78-8054-8970-1	Bed Plate for Spring
2794-20	78-8054-8571-7	Nut - Plastic
2794-21	78-8054-8968-5	Nut - Special
2794-22	78-8054-8585-7	Collar
2794-23	78-8054-8586-5	Pin
2794-24	78-8054-8584-0	Spacer
2794-25	78-8054-8583-2	Bushing
2794-26	78-8060-8497-2	Bushing - Lead Screw
2794-27	78-8059-5617-0	Screw - Set, M6 x 8
2794-28	78-8060-8498-0	Bushing - Inner Column
2794-29	78-8060-8499-8	Sprocket - 3/8"
2794-30	78-8070-1500-9	Screw - Soc Hd Hex Hd M4 X 25
2794-31	78-8070-1501-7	Chain - 3/8"
2794-32	78-8070-1502-5	Housing - Chain
2794-33	78-8060-7878-4	Screw - Idler
2794-34	78-8070-1503-3	Roller - Chain Tensioning
2794-35	78-8042-2919-9	Washer - M6
2794-36	26-1003-5828-7	Screw - Hex Hd M6 x 12
2794-37	26-1000-0010-3	Washer - Flat M6
2794-38	78-8070-1504-1	Cover
2794-39	26-1002-5753-9	Screw - Self Tapping
2794-40	78-8070-1505-8	Cap - Inner Column
2794-41	78-8070-1506-6	Cover - Screw
2794-42	78-8076-4705-8	Crank Assembly W/Block
2794-43	78-8070-1508-2	Crank
2794-44	78-8070-1509-0	Shaft - Crank
2794-45	26-1005-5316-8	Screw - Flat Hd Hex Dr M5 x 16
2794-46	78-8070-1510-8	Washer - /7 X 15 X 1 Nylon
2794-47	78-8070-1511-6	Bushing
2794-48	78-8005-5740-3	Washer - Plain 4mm, Metric
2794-49	78-8010-7157-8	Screw - Hex Hd M4 x 10, Metric
2794-50	78-8070-1512-4	Knob - VTR-B-M12
2794-51	78-8070-1548-8	Washer - Nylon 20 X 12, 5 X 1
2794-52	78-8076-4703-3	Block - Crank
2794-53	78-8060-8080-6	Guard - Stop

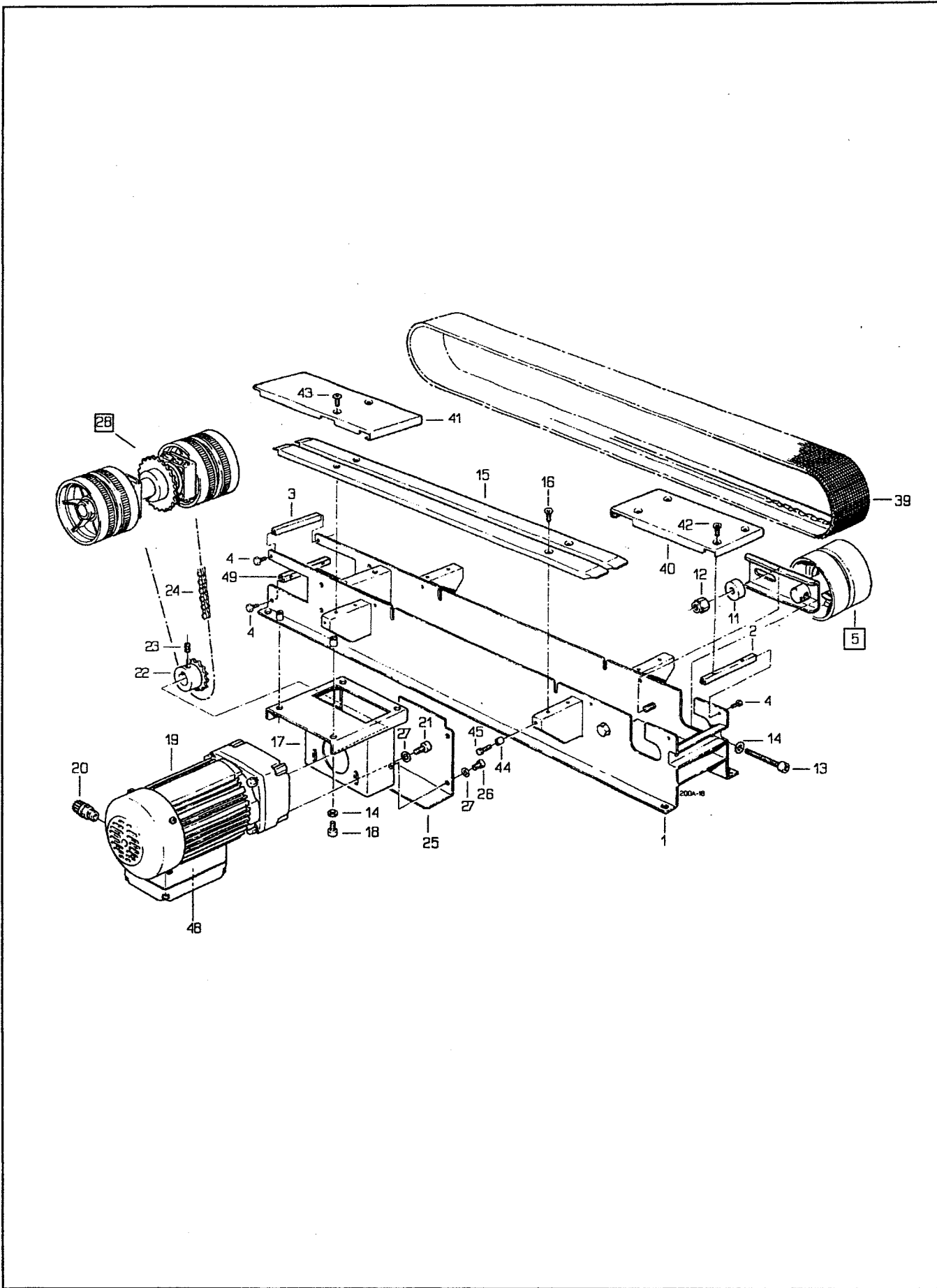

Figure 2795/1 of 2

Figure 2795 (Page 1 of 2)

Ref. No.	3M Part No.	Description
2795-1	78-8070-1513-2	Frame - Drive
2795-2	78-8070-1514-0	Spacer
2795-3	78-8070-1515-7	Spacer
2795-4	26-1003-5828-7	Screw - Hex Hd M6 x 12
2795-5	78-8070-1516-5	Belt Tensioning Assembly
2795-6	78-8070-1517-3	Belt Tensioning
2795-7	78-8052-6710-7	Roller - Idler
2795-8	78-8052-6709-9	Washer - Special
2795-9	78-8010-7435-8	Washer - Lock M6, Metric
2795-10	26-1003-7957-2	Screw - Soc Hd Hex Hd M6 x 16
2795-11	78-8070-1518-1	Spacer - Shaft
2795-12	26-1003-6918-5	Nut - Hex M10 Plastic Insert
2795-13	78-8070-1519-9	Screw - Soc Hd Hex Hd M8 x 70
2795-14	78-8017-9318-9	Washer - Plain 8 mm, Metric
2795-15	78-8070-1520-7	Guide - Drive Belt
2795-16	26-1005-4758-2	Screw - Flat Hd M5 x 20
2795-17	78-8070-1521-5	Support - Gearbox
2795-18	26-1003-7963-0	Screw - Soc Hd M8 x 16
2795-19	78-8070-1522-3	Gear Motor 115V, 60HZ
2795-20	78-8057-5807-1	Cord - Grip
2795-21	78-8070-1523-1	Screw - 1/4-28 X 1/2 SHCS
2795-22	78-8070-1524-9	Sprocket - 3/8"
2795-23	78-8023-2479-4	Screw - Set M6 x 10, W/End Cup
2795-24	78-8070-1525-6	Chain - 3/8"

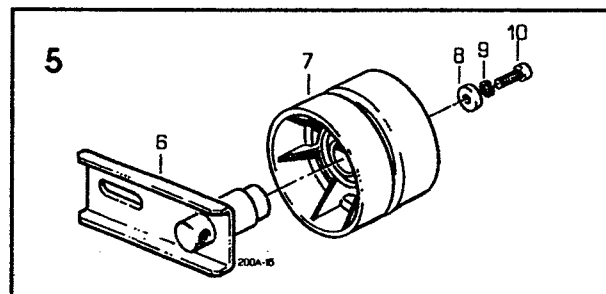
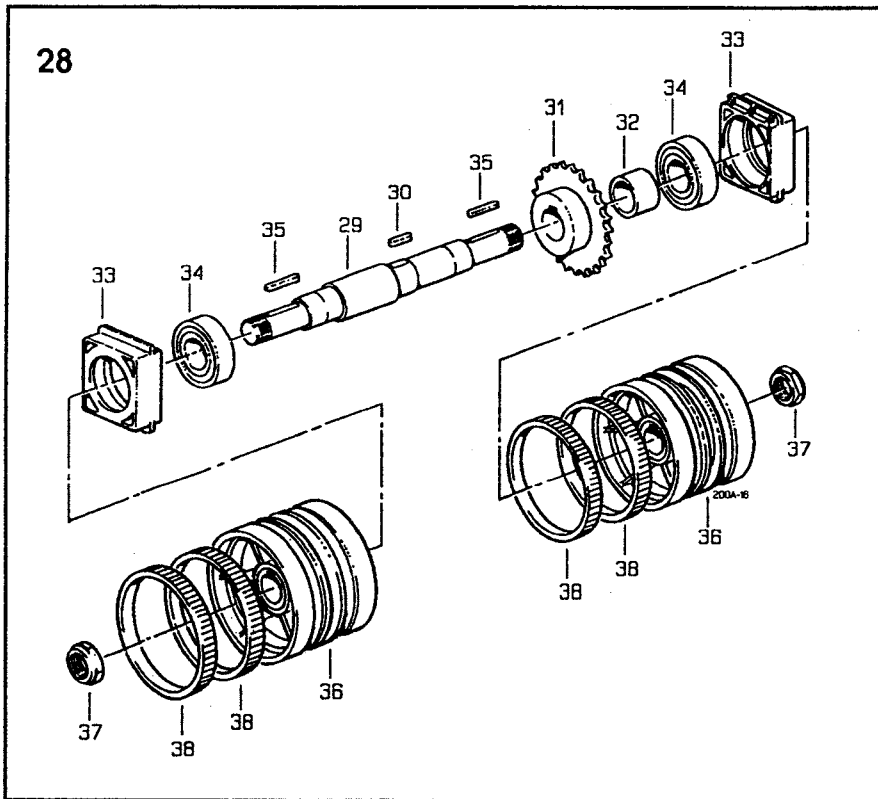
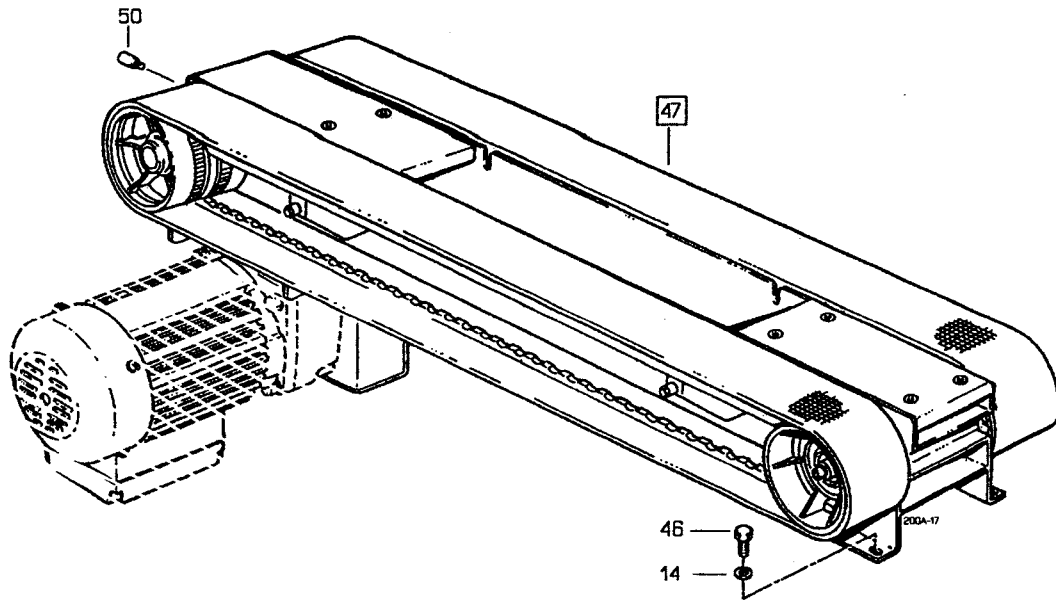

Figure 2795/2 of 2

Figure 2795 (Page 2 of 2)

Ref. No.	3M Part No.	Description
2795-25	78-8070-1526-4	Cover - Chain
2795-26	78-8010-7209-7	Screw - Soc Hd M6 X 12
2795-27	26-1000-0010-3	Washer - Flat M6
2795-28	78-8070-1527-2	Shaft - W/Drive Pulleys
2795-29	78-8070-1528-0	Shaft - Gearbox
2795-30	78-8057-5811-3	Key - 6 X 6 X 20 mm
2795-31	78-8054-8986-7	Sprocket - 3/8" Pitch, 28 Teeth
2795-32	78-8054-8984-2	Bushing
2795-33	78-8070-1529-8	Support - Shaft
2795-34	78-8070-1530-6	Bearing - 6205-2R5
2795-35	78-8057-5739-6	Key - M5 X 5 X 30 mm
2795-36	78-8060-8072-3	Roller - Drive
2795-37	78-8060-8416-2	Nut - Special M20 X 1
2795-38	78-8052-6713-1	Ring - Polyurethane
2795-39	78-8070-1531-4	Belt - Drive W/Hook
2795-40	78-8070-1532-2	Plate - Front
2795-41	78-8070-1533-0	Plate - Rear
2795-42	26-0001-5862-1	Screw - Flat Hd Soc M5 X 12
2795-43	26-1005-5316-8	Screw - Flat Hd Hex Dr M5 x 16
2795-44	78-8070-1534-8	Stud - Side Plate
2795-45	78-8060-8488-1	Screw - Hex Hd M5 X 20
2795-46	26-1003-5841-0	Screw - M8 X 16
2795-47	78-8070-1535-5	Bottom Drive Assembly
2795-48	78-8076-4515-1	Capacitor - 115V Gearmotor
2795-49	78-8076-4526-8	Spacer
2795-50	78-8076-4588-8	Shaft

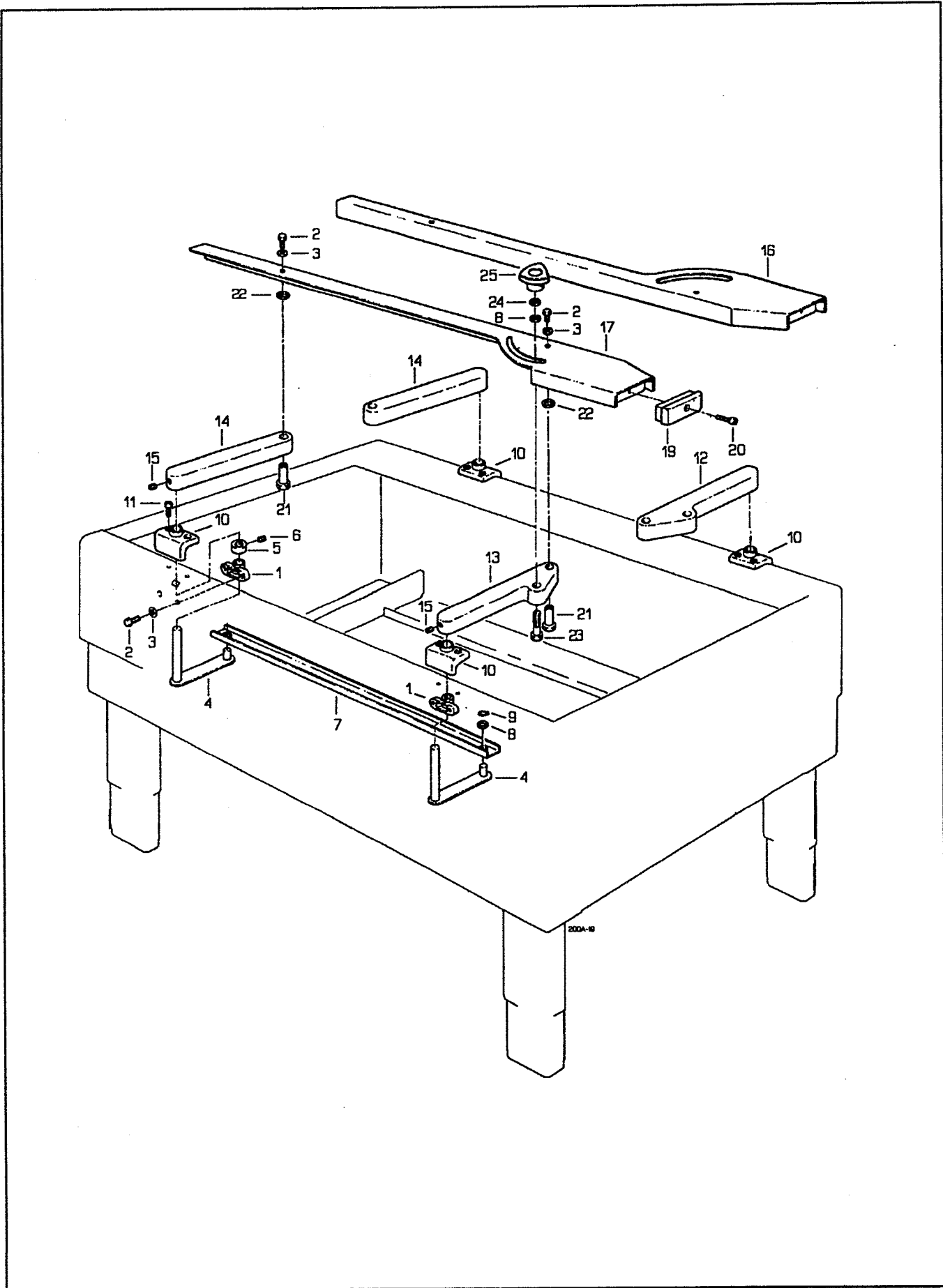

Figure 2796

Figure 2796

Ref. No.	3M Part No.	Description
2796-1	78-8070-1536-3	Support - Guide Arm
2796-2	78-8010-7169-3	Screw - Hex Hd M6 X 12, Metric
2796-3	26-1000-0010-3	Washer - Flat M6
2796-4	78-8070-1537-1	Lever With Pivot
2796-5	78-8070-1538-9	Bushing
2796-6	26-1003-8816-9	Screw - Set M5 X 6
2796-7	78-8070-1539-7	Link - Guide
2796-8	78-8017-9074-8	Washer - 15 mm Nylon
2796-9	78-8052-6733-9	Ring - M10 Special
2796-10	78-8070-1540-5	Support - Lever
2796-11	26-1003-7951-5	Screw - Soc Hd Hex Soc M5 X 20
2796-12	78-8070-1541-3	Guide Arm - Front, Right
2796-13	78-8070-1542-1	Guide Arm - Front, Left
2796-14	78-8070-1543-9	Guide Arm - Rear
2796-15	78-8076-4505-2	Screw - Set M6 X 8
2796-16	78-8070-1544-7	Guide - Right
2796-17	78-8070-1545-4	Guide - Left
2796-19	78-8070-1546-2	Cap - Guide
2796-20	26-1003-7953-1	Screw - Soc Hd M5 X 30
2796-21	78-8070-1547-0	Shaft - Guide
2796-22	78-8070-1548-8	Washer - 20 X 12, 5 X 1 Nylon
2796-23	26-1003-5852-7	Screw - Hex Hd M10 X 40
2796-24	78-8052-6566-3	Washer - Friction
2796-25	78-8070-1549-6	Knob - VIR-B-M10

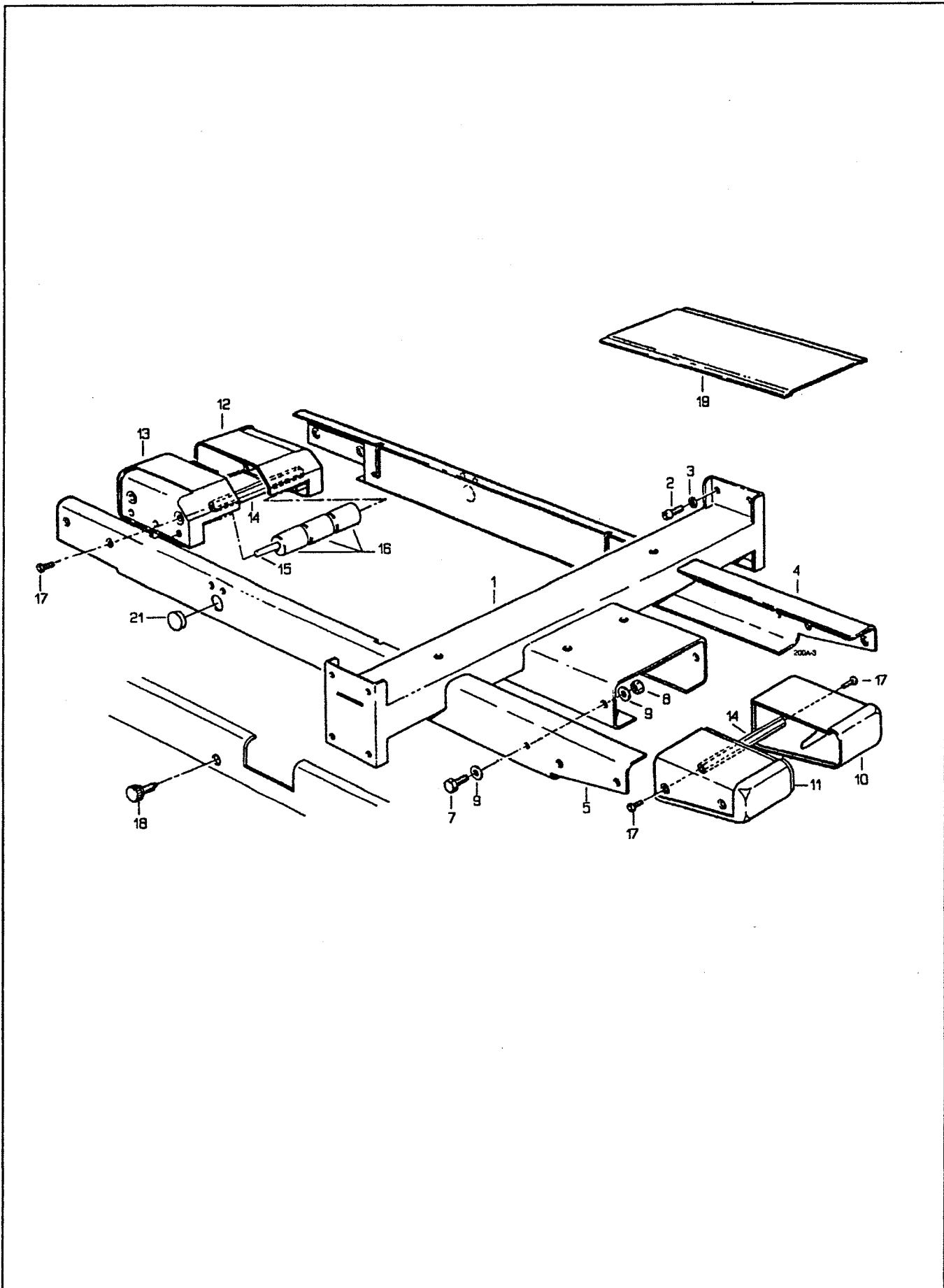

Figure 2797

Figure 2797

Ref. No.	3M Part No.	Description
2797-1	78-8070-1550-4	Bar
2797-2	26-1003-7957-2	Screw - Soc Hd Hex Hd M6 X 16
2797-3	26-1000-0010-3	Washer - Flat M6
2797-4	78-8070-1551-2	Side Plate - Right
2797-5	78-8070-1552-0	Side Plate - Left
2797-7	26-1003-5842-8	Screw - Hex Hd M8 X 20
2797-8	26-1000-1347-8	Nut - Hex M8, Metric
2797-9	78-8017-9318-9	Washer - Plain 8 mm, Metric
2797-10	78-8070-1574-4	Slide - Front, Right
2797-11	78-8070-1575-1	Slide - Front, Left
2797-12	78-8070-1576-9	Slide - Rear, Right
2797-13	78-8070-1577-7	Slide - Rear, Left
2797-14	78-8070-1553-8	Spacer
2797-15	78-8070-1554-6	Stud
2797-16	78-8060-7693-7	Roller - 32 X 38
2797-17	26-1005-5316-8	Screw - Flat Hd Hex Dr M5 x 16
2797-18	78-8070-1555-3	Block - Upper Head
2797-19	78-8070-1556-1	Cover
2797-21	78-8076-4517-7	End Cap /22 X 11

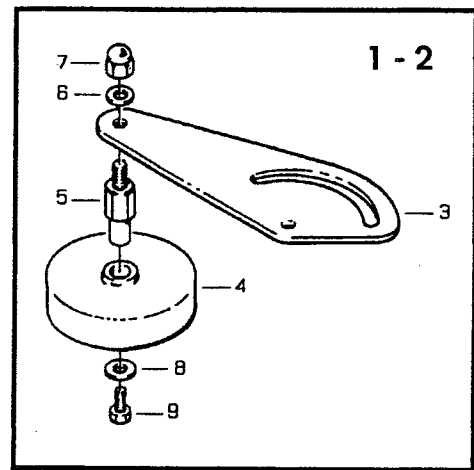
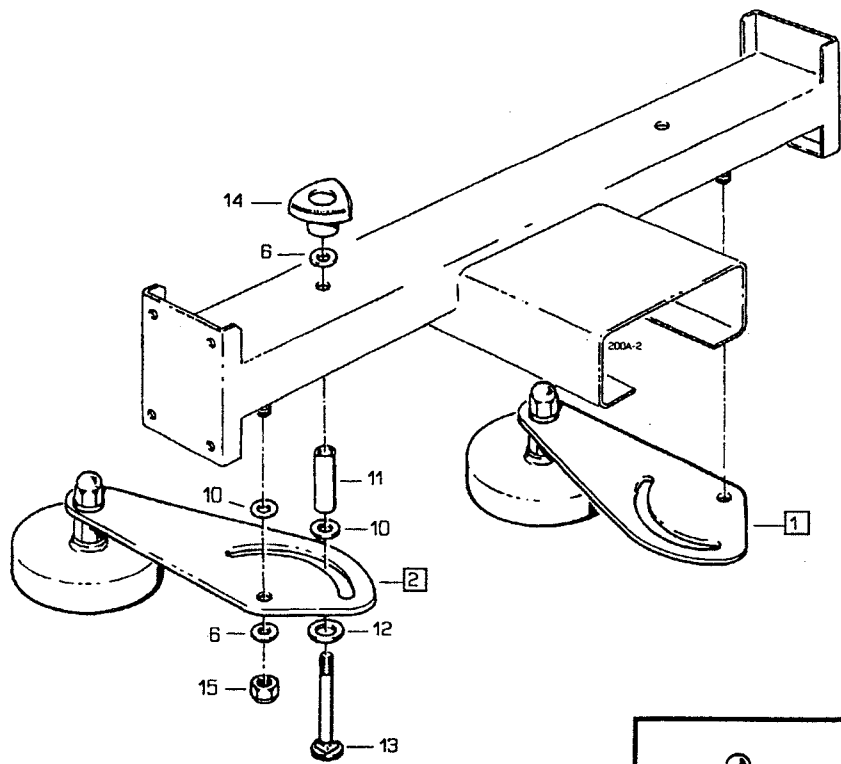

Figure 2798

Figure 2798

Ref. No.	3M Part No.	Description
2798-1	78-8070-1557-9	Compression Roller Assembly - Right
2798-2	78-8070-1558-7	Compression Roller Assembly - Left
2798-3	78-8070-1559-5	Support - Compression Roller
2798-4	78-8054-8648-3	Pressure Roller
2798-5	78-8070-1560-3	Stud - Roller Mounting
2798-6	78-8052-6566-3	Washer - Friction
2798-7	78-8070-1561-1	Nut - M10
2798-8	26-1004-5507-5	Washer - M8
2798-9	26-1003-5841-0	Screw - M8 X 16
2798-10	78-8017-9074-8	Wassher - 15 mm Nylon
2798-11	78-8070-1562-9	Tube - Roller Support
2798-12	12-7991-1752-3	Washer - M14 Plain
2798-13	78-8070-1563-7	Screw - M10 X 80
2798-14	78-8070-1549-6	Knob - VTR-B-M10
2798-15	26-1003-6918-5	Nut - Plastic Insert M10 Hex Flange

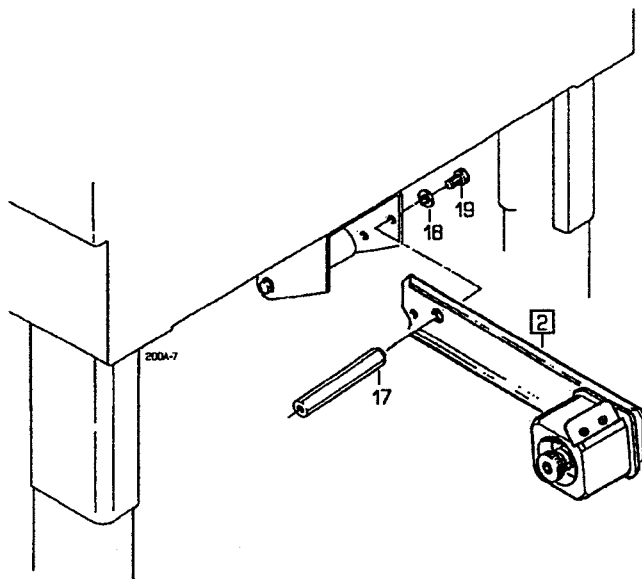
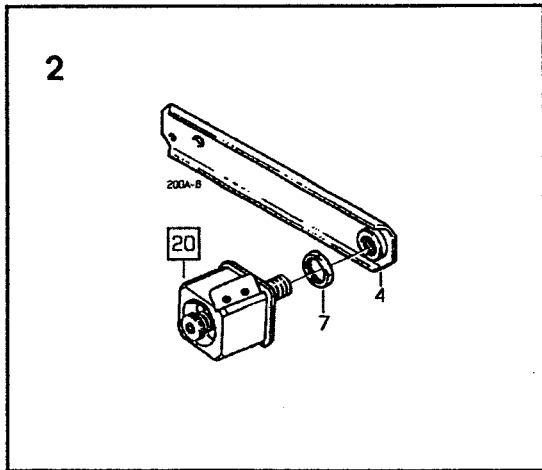
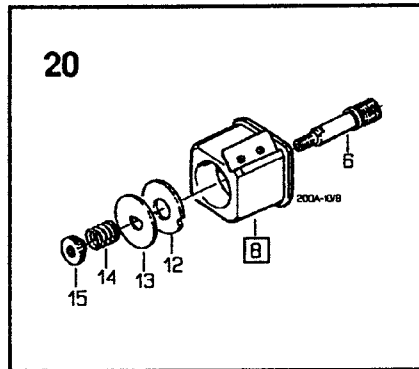
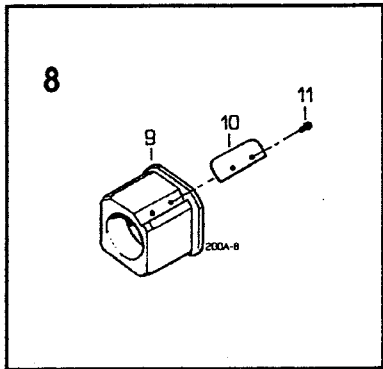
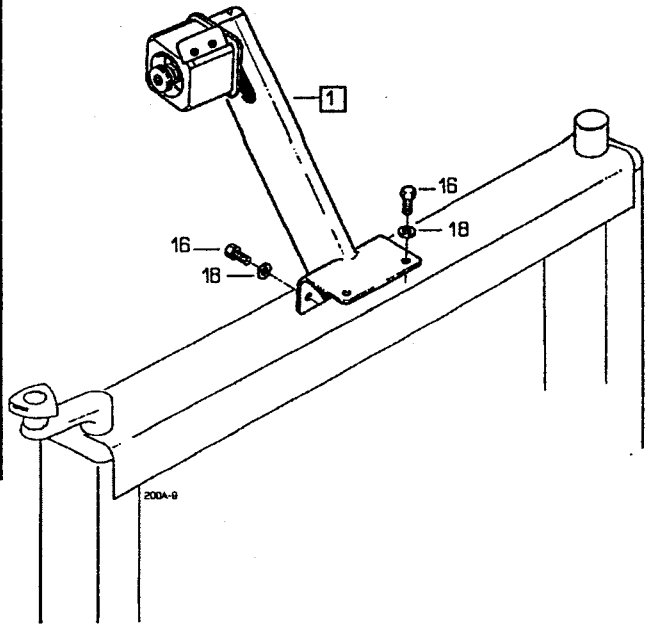
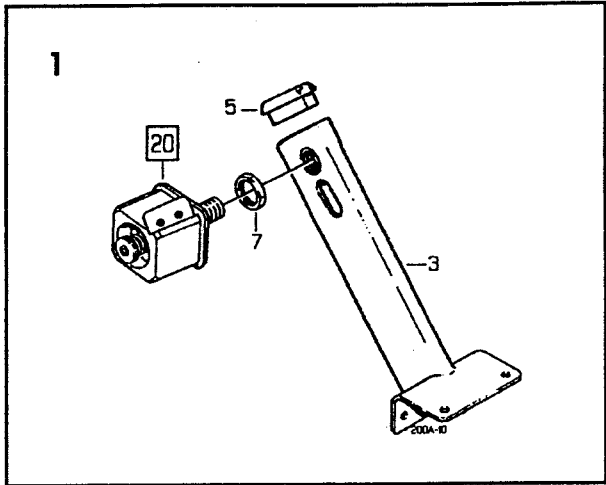

Figure 2799

Figure 2799

Ref. No.	3M Part No.	Description
2799-1	78-8070-1564-5	Tape Drum Bracket Assembly
2799-2	78-8070-1565-2	Tape Drum Bracket Assembly
2799-3	78-8070-1566-0	Bracket - Tape Drum
2799-4	78-8070-1395-4	Bracket - Bushing Assembly
2799-5	78-8070-1568-6	Cap - Bracket
2799-6	78-8076-4519-3	Shaft - Tape Drum 2 Inch
2799-7	78-8017-9169-6	Nut - M18 X 1
2799-8	78-8070-1569-4	Tape Drum Assembly
2799-9	78-8052-6749-5	Tape Drum Assembly
2799-10	78-8052-6268-6	Leaf Spring
2799-11	26-1002-5753-9	Screw - Self Tapping
2799-12	78-8060-8172-1	Washer - Friction
2799-13	78-8052-6271-0	Washer - Tape Drum
2799-14	78-8054-8826-5	Spring
2799-15	78-8060-7851-1	Ring Nut - Adjusting
2799-16	78-8060-7886-7	Screw - Hex Hd M6 X 16
2799-17	78-8070-1215-4	Spacer - Stud
2799-18	26-1000-0010-3	Washer - Flat M6
2799-19	26-1003-5828-7	Screw - Hex Hd M6 X 12 , Metric
2799-20	78-8060-8474-1	Tape Drum Assembly - 2 Inch Head

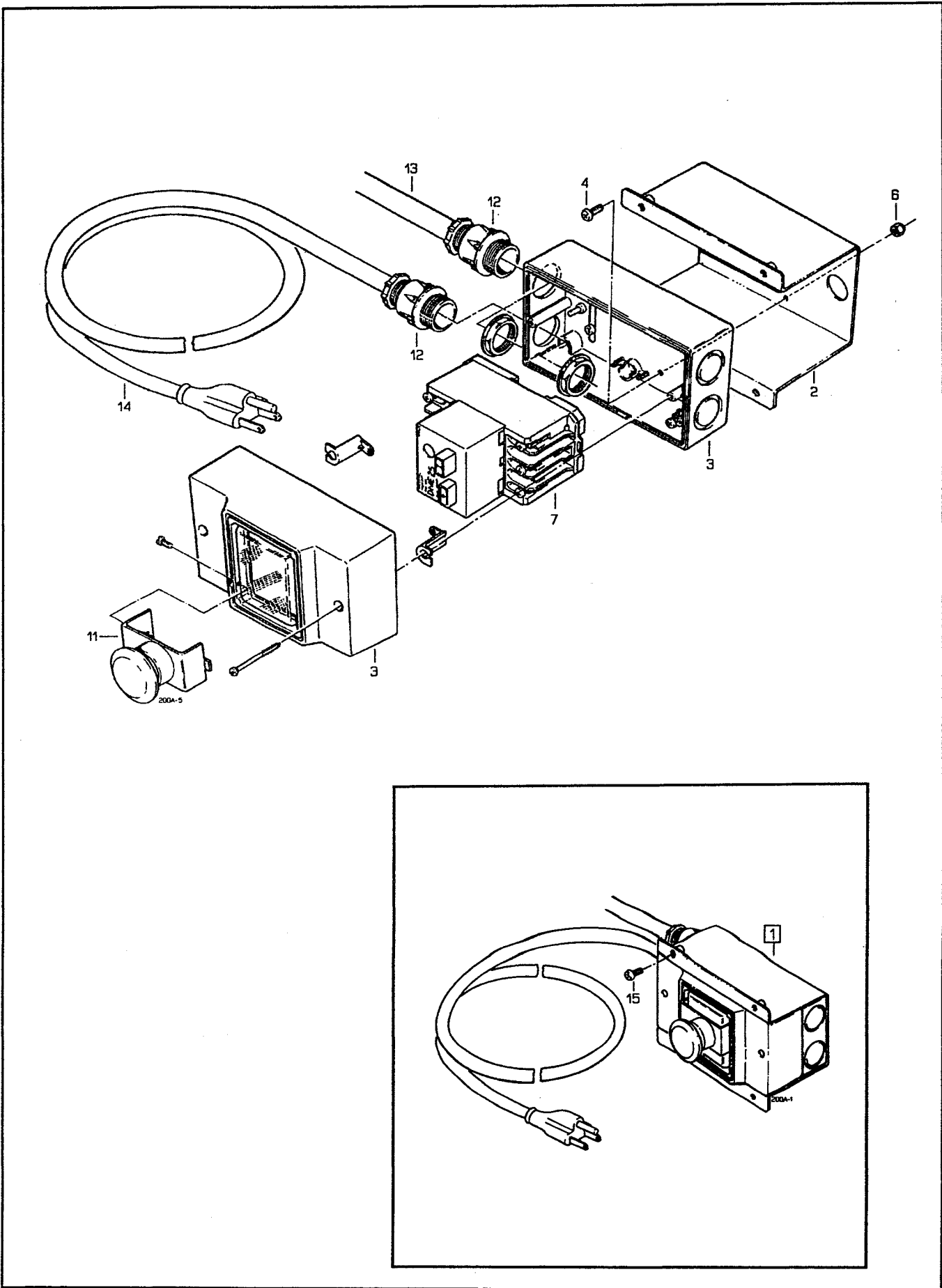
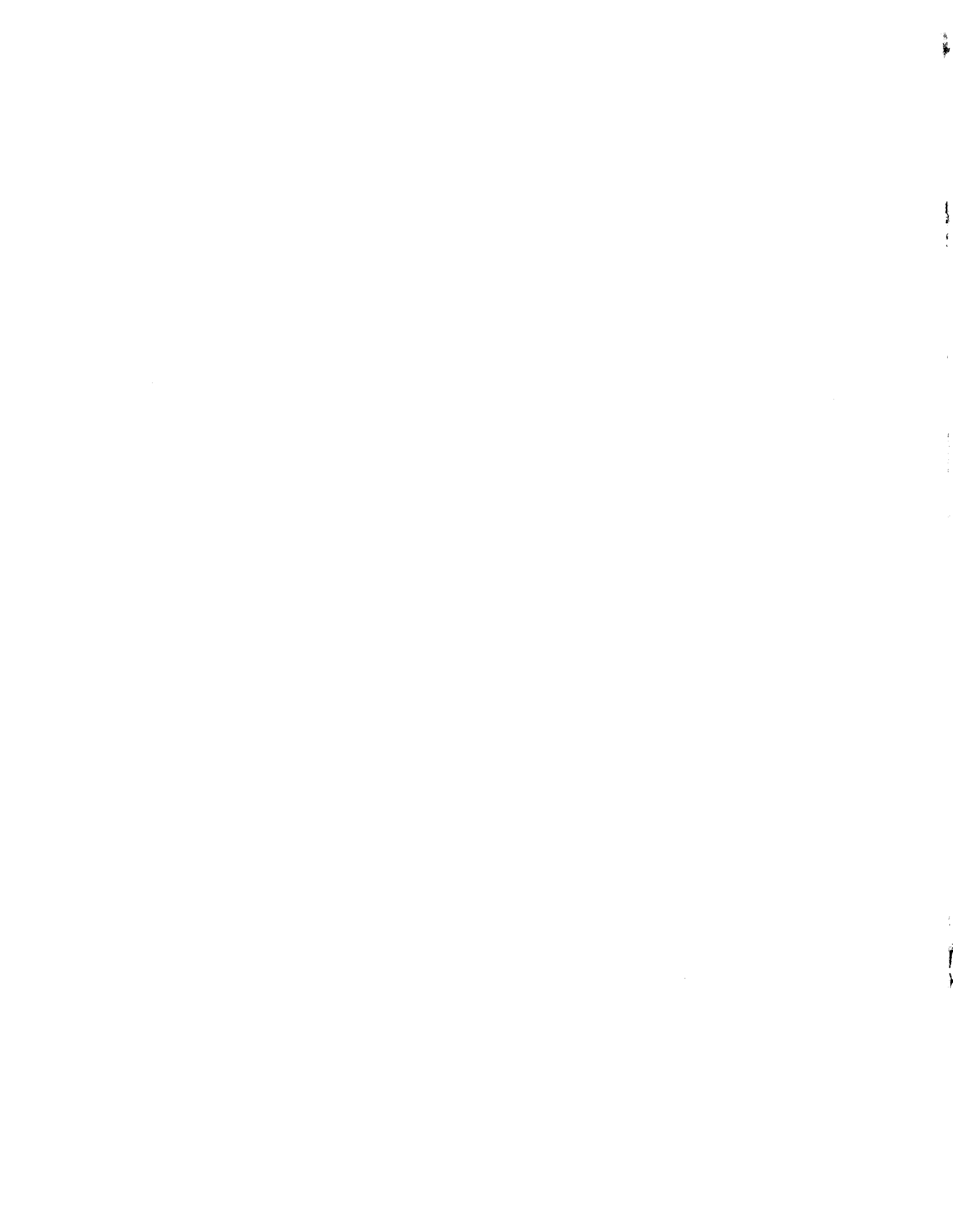

Figure 2800

Figure 2800

Ref. No.	3M Part No.	Description
2800-1	78-8070-1571-0	Switch - On/Off With Support
2800-2	78-8070-1572-8	Switch - Support
2800-3	78-8070-1573-6	Box - On/Off Switch
2800-4	78-8017-9257-9	Screw - Phillis Hd M4 X 10
2800-6	26-1003-6914-4	Nut - Plastic Insert M4
2800-7	78-8052-6728-9	Switch - On/Off 1,6 - 2,5 AMP (set at 2.3 AMPS)
2800-11	78-8052-6725-5	Emergency Stop
2800-12	78-8057-5807-1	Cord - Grip
2800-13	78-8060-8053-3	Cable - 3 X 1,5 5MT 1PH
2800-14	78-8028-7909-4	Power Cord U.S.A.
2800-15	78-8060-8087-1	Screw - M5 X 10, Metric



3M Parts Order Form

Form 26989 - 3 - D

Mall To: Dispenser Parts
 241 Venture Drive
 Amery, WI 54001

Fax or Call: 715-268-8126 (Wisc.)
 800-344-9883 (Outside Wisc.)
 FAX# 715-268-8153

-- Shaded Areas To Be Filled In By 3M --

P.O. No.		Date		Catalog No.		Phone No. (including Area Code)		Customer Name	
Attn.		Model No.		Serial No.		Sales Rep No.		Invoice No.	
Change Back		Do Not Charge Back		Via		Account No.		Appropriation No.	
Tax Exempt No.		SIC		Special Instructions		Charge To			

FAX Your Order For Faster Service FAX No. 715-268-8153

Qty.	Part Number	Description	Price
1.			
2.			
3.			
4.			
5.			
6.			
7.			
8.			
9.			

Please Print

\$25.00 Minimum Order Ship Via Air At Customer Expense Signature



