



**Model “DRF, WRF and  
WRF 30ppm NOx”  
Forced Draft Water Boiler  
(also known as DF & WF)**

**Operating and Maintenance Manual**

***Designed and Manufactured in Accordance with  
ASME Code Section IV, Heating Boilers***



*Photo shown may vary from actual model.*



E.T.L. Listed



E.T.L.  
Canadian  
Listed



ASME



ASME



## Table of Contents

---

Page	
3	<b>Operating and Installation Instruction</b>
4	<b>The Boiler Name Plate and Model Number</b>
5	<b>The Parts of the Boiler</b> <ul style="list-style-type: none"><li>Exploded Boiler View</li><li>Parts</li></ul>
6	<b>Receiving your Boiler and Installation</b> <ul style="list-style-type: none"><li>Code requirements</li><li>Boiler placement</li><li>Combustion air</li><li>Venting</li><li>Relief valve</li><li>Check burner</li><li>Stud nuts on boiler headers</li><li>Water connections</li><li>Gas connections</li><li>Manual main gas shut-off valve</li><li>Fuel oil connections</li><li>Electrical</li><li>Pump selection</li><li>Expansion tank</li><li>Indoor &amp; outdoor boilers</li></ul>
9	<b>Size of Piping to Gas Boilers</b> <ul style="list-style-type: none"><li>Pipe delivery schedule</li><li>Additional length of pipe to be added for each elbow or tee bend in the line</li></ul>
10	<b>Installation Diagram – DRF Model</b>
11	<b>Installation Diagram – WRF &amp; WRF-NOx Model</b>
12	<b>Installation with Refrigeration System</b>
13	<b>Water Treatment</b>
14	<b>Before Start-up</b> <ul style="list-style-type: none"><li>Clean system</li><li>Fill the boiler</li><li>Fill oil tank</li><li>Additional controls</li><li>Venting</li><li>Check factory assembled joints and head bolts</li></ul>
15	<b>Start-up Instruction – Gas</b> <ul style="list-style-type: none"><li>After start-up check list</li><li>Shutting down the boiler</li></ul>
17	<b>Start-up Instruction – Oil</b> <ul style="list-style-type: none"><li>After start-up check list</li><li>Shutting down the boiler</li></ul>
19	<b>Maintenance Instruction</b> <ul style="list-style-type: none"><li>Maintenance intervals</li><li>Removing and sealing the manway access door</li></ul>
25	<b>Adjusting Gas Pilots on Power Flame C &amp; J Burners</b>
26	<b>Trouble-shooting Guide</b> <ul style="list-style-type: none"><li>Condensation</li><li>Cold start-up</li><li>Sooting</li></ul>
28	<b>Quick Reference Guide</b> <ul style="list-style-type: none"><li>Replacement parts</li><li>Material Safety Data Sheet</li><li>Contact Us</li></ul>
	<b>Warranty</b>
	<b>Manufacturers Cut-Sheets</b> ( <i>Disclaimer: Some parts may vary from actual model</i> )

## Operating and Installation Instructions (Model DRF, WRF, & WRF-NOx)

---

Congratulations on your purchase of a new Ajax Boiler. In this book, we have included installation and maintenance instructions that, if followed, will provide you with many years of service from your boiler. Also included are instruction manuals for each of the controls furnished with the boiler. Please read them carefully. They should be helpful in both the installation and services of the boiler. Keep these instructions with the boiler for future reference.

The Ajax water boiler is of rugged construction, yet of simple design. The boiler is of the inclined water tube type, consisting of two water headers with interconnecting, 2" O.D., straight inclined tubes. Normally, steel tubes are supplied on "closed" systems where the amount of make-up water is negligible. Copper tubes should be used on "raw" water applications, where a total or a high percentage of water make up takes place, or where water with high corrosive properties is encountered.

The tubes are rolled and flared into tube sheets with a minimum 1/2" thick, P.V. quality steel plate. The boiler is equipped with removable head plates, front and rear, giving easy access to the straight tubes for inspection, cleaning or replacing.

The combustion chamber and flue passages are designed to give maximum efficiency and serviceability. The best grade of castable refractory is used. Expansion joints are provided to allow for normal contraction and expansion of the refractory. The refractory is backed up with 3" of rockwool insulation. The boiler is enclosed in a casing of 18 gauge-galvanized steel.

The boiler serial number is stamped on the front header plate and on the boiler nameplate, generally mounted on the right hand side of the boiler. All boilers furnished with copper tubes will have a decal applied on the front and rear head plates and will have sacrificial anodes fixed in the water box section of the head plates.

Experience in the field has proven that the Ajax Boilers, if properly applied and maintained, will give many years of efficient, dependable and economical service.

## The Boiler Nameplate And Model Number

### The Boiler Name Plate

The following illustration is an accurate depiction of the nameplate found on the right hand side of the boiler. You will also find an ASME nameplate on the front head plate with some of the same information.

- A. Boiler description
- B. Model number
- C. Serial number
- D. Minimum relief valve capacity
- E. Maximum Btu/Hr fuel input
- F. Maximum Btu/Hr output\*\*
- G. Boiler horsepower
- H. Square feet of heating surface
- I. Minimum Btu/Hr fuel input\*
- J. Minimum Btu/Hr output\*\*\*
- K. Gross E.D.R.
- L. Max. allowable working press.\*\*\*
- M. Supply voltage
- N. Electrical supply Hertz
- O. Electrical supply Phase
- P. Required Amperage
- Q. Motor amp draw\*\*\*\*
- R. Control voltage\*\*\*\*
- S. Control amp draw\*\*\*\*
- T. Min. Gas pressure\*\*\*\*\*
- U. Max. Gas pressure\*\*\*\*\*
- V. Manifold gas pressure\*\*\*\*\*
- W. Fuel type (See model #)
- X. Gallons per hour oil\*\*\*\*
- Y. Int. Group Prim Safety\*\*\*\*
- Z. Minimum distances btw. boiler and adjacent construction.

The nameplate form includes the following fields:

- A:** Boiler description
- B:** MODEL NUMBER
- C:** SERIAL NUMBER
- D:** MIN. RELIEF VALVE CAP.
- E:** MAX. BTU/HOUR INPUT
- F:** BTU/HOUR OUTPUT
- G:** H.P.
- H:** HEATING SURFACE
- I:** MIN. BTU/HOUR INPUT
- J:** BTU/HOUR OUTPUT
- K:** GROSS E.D.R.
- L:** M.A.W.P. PSIG
- M:** VOLTS
- N:** HERTZ
- O:** PH
- P:** AMPS
- Q:** MOT. AMPS
- R:** CTRL. VOLT
- S:** CTRL. AMP
- T:** MIN. GAS PRESS. IN. W.C.
- U:** MAX. GAS PRESS. IN. W.C.
- V:** MANIFOLD PRESS. IN. W.C.
- W:** FUEL TYPE
- X:** #2 OIL GPH
- Y:** INTEGRAL GROUP PRIMARY SAFETY
- Z:** MINIMUM CLEARANCES TO ADJACENT CONSTRUCTION (TOP, SIDES, REAR, FLUE)

NOT FOR INSTALLATION ON COMBUSTIBLE FLOORING

- \* Minimum Btu/Hr ratings apply to high-low and modulating type boilers only.
- \*\* Boiler output ratings are based on factory tests under appropriate conditions. Field results may vary.
- \*\*\* Maximum allowable working pressure for boiler only. Relief valve set pressure should not exceed the lowest MAWP of any component in your system.
- \*\*\*\* Applies to forced draft type burners only
- \*\*\*\*\* Minimum and maximum gas pressure values are measured at the point of connection to the boiler gas train. Manifold gas pressures are measured after the gas train.

### The Boiler Model Number

**DRFG50W**

#### Type of boiler:

- WR = 125 PSIG MAWP Hot Water
- HR = 15 PSIG MAWP Low Pressure Steam
- SR = 150 PSIG MAWP High Pressure Steam

DR = 150 PSIG MAWP Hot Water

#### Type of burner:

- N = Atmospheric (H-Burner)
- F = Forced Draft
- E = High Efficiency Forced Draft
- P = Premix Low NOx
- R = Atmospheric (Round Burner)

#### Firing Rate:

150 = 150,000 Btu/Hr.  
(On high pressure steam, # represents HP)

#### Fuel Type:

- G = Natural Gas
- P = Propane
- C = Combination #2 Oil/Natural Gas

- W = Outdoor
- O = #2 Oil
- D = Dual Gas (Natural Gas/Propane)

## The Parts of the Boiler

### Exploded Boiler View

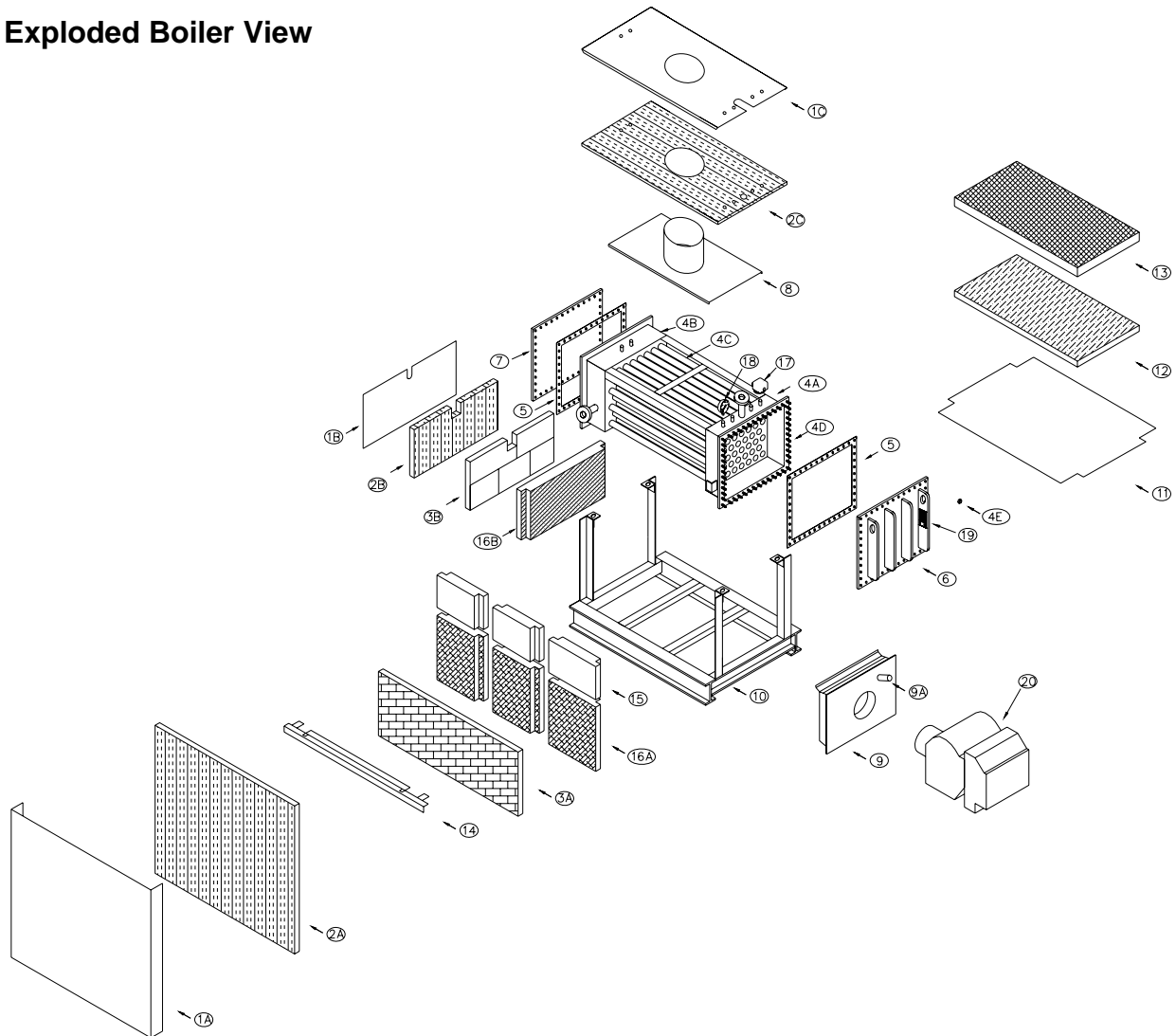

### Parts

1a	Outer sheet metal jacket	7	Rear head plate
1b	Rear jacket	8	Flue collector
1c	Upper jacket panel	9,9a	Firebox door, glass eye
2a-c	Thermafiber	10	Frame
3a/b	Thermotek Block	11	Galvanized floor
4a	Header	12	Castable refractory
4b	Waterbox	13	Kastite
4c	Tubes	14	Refractory support
4d	Head plate studs	5	Header gasket
16a-b	Refractory	4e	Head plate nuts
15	TCO panels	17,18	Low water probe , Pressure gauge
6	Front head plate	19,20	ASME data plate, Forced draft burner

See manufacturer's cut-sheets enclosed with the boiler for complete information on the various parts.

## Receiving your boiler And Installation

---

### Receiving your boiler

Check Equipment Received: Inspect the boiler for any shipping damage. Make sure you have received all loose parts, such as draft hoods or controls packaged separately, which are listed on the packing slip. Note any damages or shortages on the bill of lading prior to signing it. *If a boiler is received damaged or missing parts, it is your responsibility to notify the shipping company and file a freight claim.* Ajax Boiler cannot send replacement parts for freight damaged or missing equipment as warranty items. Consignee must file claims for shortages and damages with the carrier. Permission to return goods must be received from the factory prior to shipping. Goods returned without a Returned Goods Authorization number will not be accepted. Purchased parts are subject to replacement only under the manufacturer's warranty. The warranty does not include the cost of labor, removal, or installation of the warranted part.

### Installation

**Code Requirements:** It is very important that your installation comply with all federal, state and local codes (NFGC, NEC, NFPA, CSD-1) as well as meet good industry practices as shown in publications issued by ASME, AGA, UL, ASHRAE, ABMA, ANSI etc.

**Boiler Placement:** The boiler should be placed on a solid foundation, preferably a concrete pad, adequately sized for your boiler. Ajax Boilers are not suitable for installation on combustible surfaces. Electrical conduit **should not** be imbedded in the concrete directly under the boiler without first consulting with the engineer of the approved boiler pad. Provide adequate clearance for normal inspection and maintenance purposes and allow proper clearances for combustion air. Also, allow tube pull length clearance in the front or rear of the boiler for servicing (see boiler dimensions page for tube lengths). The minimum clearances to combustible surfaces are listed under the UL-795 clearance guidelines and on the boiler nameplate. Make sure the boiler is level, from side to side and front to back. Use metal shims if necessary.

**Combustion Air:** Adequate combustion air is one of the most important requirements for an atmospheric fired boiler. A lack of proper airflow can result in poor combustion, sooting and premature failure to the boiler. Sizing combustion air intakes according to the National Fuel Gas Code or NFPA 54 is acceptable. Ventilation openings should be provided per the National Fuel Gas Code. The boiler room should have two permanent openings. One opening shall be within two feet of the ceiling and one more within two feet of the floor. Each opening should have a free area of not less than 1 square inch per 1,000 BTU/HR of the total input of every combustion product in the boiler room. The openings should not be obstructed from the outside and air conditioning or exhaust fans should not interfere with proper airflow and ventilation of the boiler room. Consideration should always be given to the blocking effect of louvers in determining total free area. Always leave adequate clearance around the base of the boiler to allow the combustion air to freely enter the combustion chamber. The combustion air entering the boiler must be free of hazardous and flammable vapor fumes. This includes such fumes as perchlorethylene, chlorine, etc.

**Venting:** This particular boiler will produce positive and negative draft conditions as a result of the burner firing. All possible points of air infiltration or ex-filtration must be sealed. If the unit is to be fired under positive combustion chamber conditions, extreme care must be taken to ensure that a 100% seal is maintained. Please consult with a stack specialist for use of appropriate stacking material. Before attaching the breeching or extending the stack, be sure there are no obstructions or foreign materials in the vent or on the tubes of the boiler. The boiler should be vented as directly as possible. The stack must be the same diameter as the boiler vent or the combined area of multiple boiler vents. The recommended upward slope of the horizontal breeching is 1" per linear foot. In other words, the stack should rise 1" vertically for each foot horizontally. The stack should reach at least 3 feet above the highest obstruction of the roof to insure proper venting. The stack must be equipped with an appropriate

weather cap of the correct size. At no time should the boiler support the stack weight. (Refer to the latest version of the National Fuel Gas Code for additional installation requirements).

When a draft inducer is required, a draft proving switch must be wired to the boiler to prevent the boiler from firing unless the draft is proven.

**Relief Valve:** The relief valve discharge must be piped to a floor drain to eliminate the potential of scalding burns. The drain line must be the same size as the relief valve outlet and have a downward slope to insure proper drainage. The drain line termination should be visible to see discharge. Check the relief valve nameplate. The boiler operating pressure cannot exceed that listed on the relief valve. Also, confirm the boiler does not exceed the maximum Btu rating on the relief valve.

**Check Burner:** Check the burner mounting bolts and tighten if loose.

**Stud Nuts on Boiler Headers:** During shipment, the head plate nuts may loosen. Tighten these if required to the torques specified later in this manual. After the boiler has been in operation for a few days, check and retighten the head plate nuts. Refer to [Quick Reference Guide](#).

**Water Connections:** See typical piping diagram as shown in the installation instructions (page 10).

**Gas Connections:** Check supply gas pressure and select gas line pipe size for adequate capacity at boiler firing rate. Install a condensate trap in the gas line ahead of the boiler gas valve regulator. Do not use Teflon tape on the gas line pipe threads. Use a pipe compound rated for use with gas. All gas piping must be leak tested after installation as components may work loose during shipment. Do not check for gas leaks with an open flame. Use a bubble test. Do not test the boiler gas piping at a pressure higher than the boiler maximum gas pressure rating as this can damage the gas train components. Support the gas piping with hangers, not by the boiler or its accessories.

**Manual Main Gas Shutoff Valve:** This valve is located on the upstream of the main gas pressure regulator and is normally located on the lower right side of the boiler. The gas supply is to be connected to this valve. Boilers with a minimum input rating are set for the specified rating at the factory. The minimum input rating is not adjustable in the field.

**Fuel Oil Connections (Where applicable):** Use copper tubing with flare fittings or iron pipe on all installations. All units must utilize the proper size and type of suction line oil strainers. Do not install manual valves in the return line between the pump and the tank unless required by a specific code. The fuel tank should be mounted above the pump level. If not, a two-pipe system is recommended. A check valve should be installed at the burner and a foot valve is recommended on the suction line within the fuel tank. These are installed to prevent the loss of oil supply, which can be damaging to the pump. It is recommended that prior to installation, MFPA-31 and all other national, state and local codes be followed. The size of the oil feed pipe depends on the length of line and whether the system is gravity or suction feed. (Please see the burner manual for oil line sizing). All lines should be tested for leaks after they have been installed. This should be done prior to running oil through them. The suction line should pass a vacuum test before placing oil in the tank. Plugging the tank end of the suction line may do this and connecting a vacuum gauge, valve and vacuum pump to the suction line stub in the boiler room. Air should be exhausted from the suction line until the vacuum gauge reads 24" of mercury (this figure is based on sea level conditions; for higher altitudes, corresponding lower values may be used). The valve should then be closed tightly and the test equipment should be allowed to stand for 24 hours, during which time, the gauge pressure should not decrease by more than ½ inch.



**Electrical:** The boiler is wired for 120volts 60hz 1phase and 12 amps, unless otherwise noted on the boiler nameplate. Verify the electrical supply using a voltmeter. The voltage tie-in leads are indicated on the wiring diagram. *For your safety, turn off electrical power supply at the service entrance before making any electrical connections.* This boiler contains sensitive control components and should be protected by a suitable commercial grade surge protection device and properly grounded. The boiler must be installed in accordance with the National Electric Code and in accordance with all state and local codes.

**Pump Selection:** An appropriate sized pump will need to be installed, to pump water through the boiler at its appropriate flow rate. Ajax recommends using a delta T of 20° to 40°F through the boiler. The boiler circulation pump must interlock with the boiler, so the pump will operate under normal boiler operation.

**Expansion Tank:** A properly sized expansion tank is required on the boiler-piping loop.

**Indoor Boilers:** Protect all electrical components from moisture. The venting must be completely sealed to prevent spent flue gas into the boiler room. The draft diverter must be installed on top of metal screws in the boiler vent(s) per U.L. requirement. **Note:** Boilers are not designed to support stack weight.

**Outdoor Boilers:** The boiler must not be installed under any overhang that is less than 6 feet from the top of the boiler. Outdoor boilers have been tested to light off in 40 MPH and operate in 10 MPH wind conditions. Boiler must be protected from excessive wind and or down draft conditions (see venting). Three sides must be open in the area under the overhang. All roof water drainage must be diverted away from the boiler. Outdoor forced draft boilers require vent piping with an approved rain cap.

## Size of Piping to Gas Boilers

In determining the size of gas pipe, the following factors should be considered:

- a.) Length of pipe and number of fittings.
- b.) Maximum gas consumption to be provided for (including possible future expansion).
- c.) Allowable loss in pressure from meter outlet to boiler.

The volume to be used (in cubic feet per hour) shall be determined, whenever possible, directly from BTU ratings of the boiler which will be installed and the heating value of the gas to be used. To obtain the cubic feet per hour, divide the total BTU input of the boiler by the BTU heating value per cubic foot of gas.

### PIPE DELIVERY SCHEDULE

Length of Pipe in Feet	1"	1-1/4"	1-1/2"	2"	2-1/2"	3"	4"	6"
10	520	1,050	1,600	3,050	4,800	8,500	17,500	44,000
20	350	730	1,100	2,100	3,300	5,900	12,000	31,000
30	285	590	890	1,650	2,700	4,700	9,700	25,000
40	245	500	760	1,450	2,300	4,100	8,300	22,000
50	215	440	670	1,270	2,000	3,600	7,400	19,000
75	175	360	545	1,020	1,650	2,900	6,000	16,000
100	150	305	460	870	1,400	2,500	5,100	14,000
150	120	250	380	710	1,130	2,000	4,100	11,600

\* Capacity of Pipes in Cubic Feet of Gas per Hour

\*\* Pipe sizes in the table are based on a pressure drop of 0.3 inches water column and a specific gravity of 0.60.

### ADDITIONAL LENGTH OF PIPE TO BE ADDED FOR EACH ELBOW OR TEE BEND IN THE LINE

Pipe Size Inches	Elbow	Tee
1	2.62 ft.	5.24 ft.
1-1/4	3.45 ft.	6.90 ft.
1-1/2	4.02 ft.	8.04 ft.
2	5.17 ft.	10.3 ft.
3	7.67 ft.	15.3 ft.
4 Fl.	5.37 ft.	15.1 ft.
6 Fl.	8.09 ft.	22.8 ft.

## Installation Diagram (DRF Model)

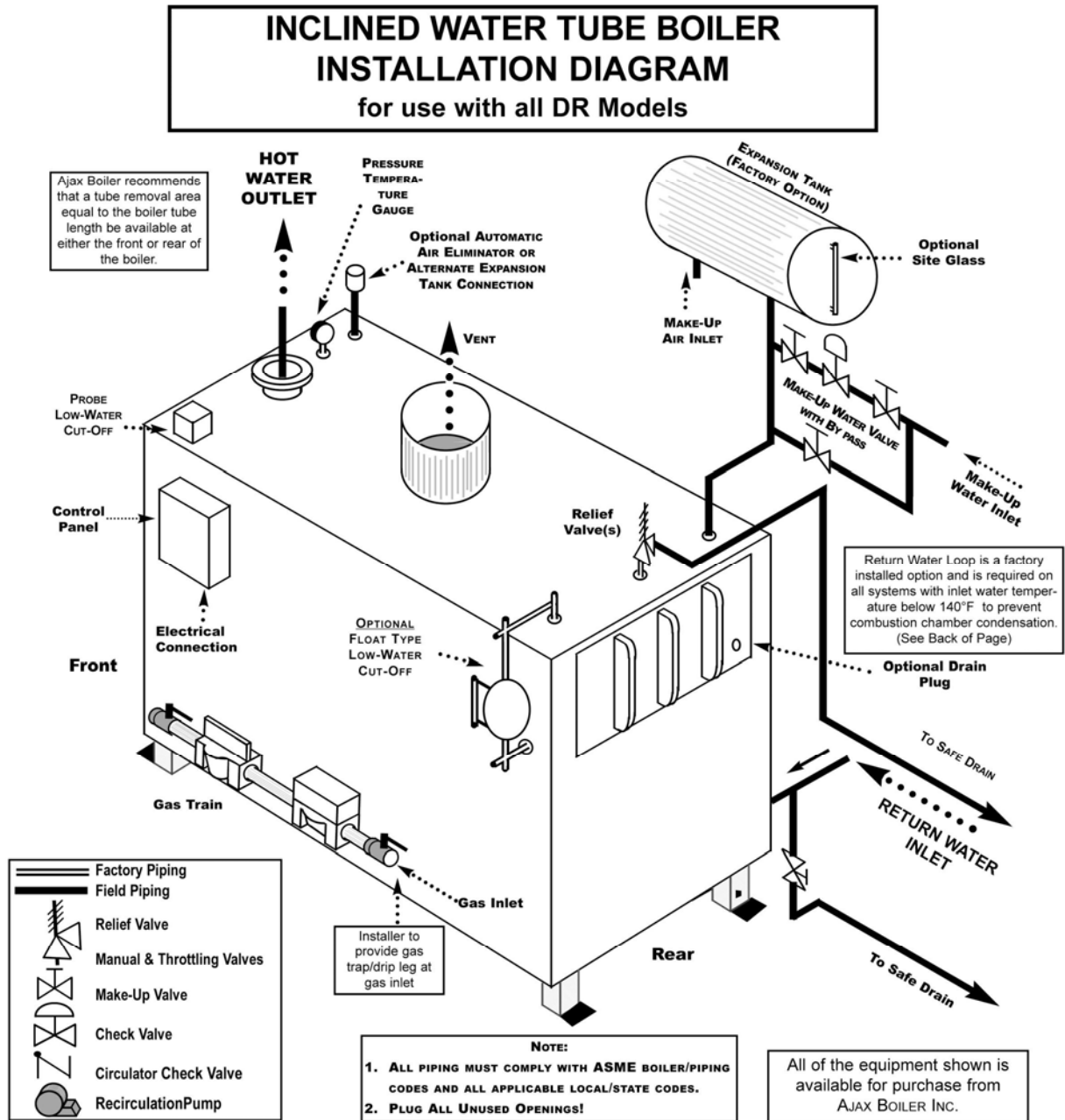

## Installation Diagram (WRF & WRF-NOx Model)

### INCLINED WATER TUBE BOILER INSTALLATION DIAGRAM for use with Models WN, WF, WE, WP

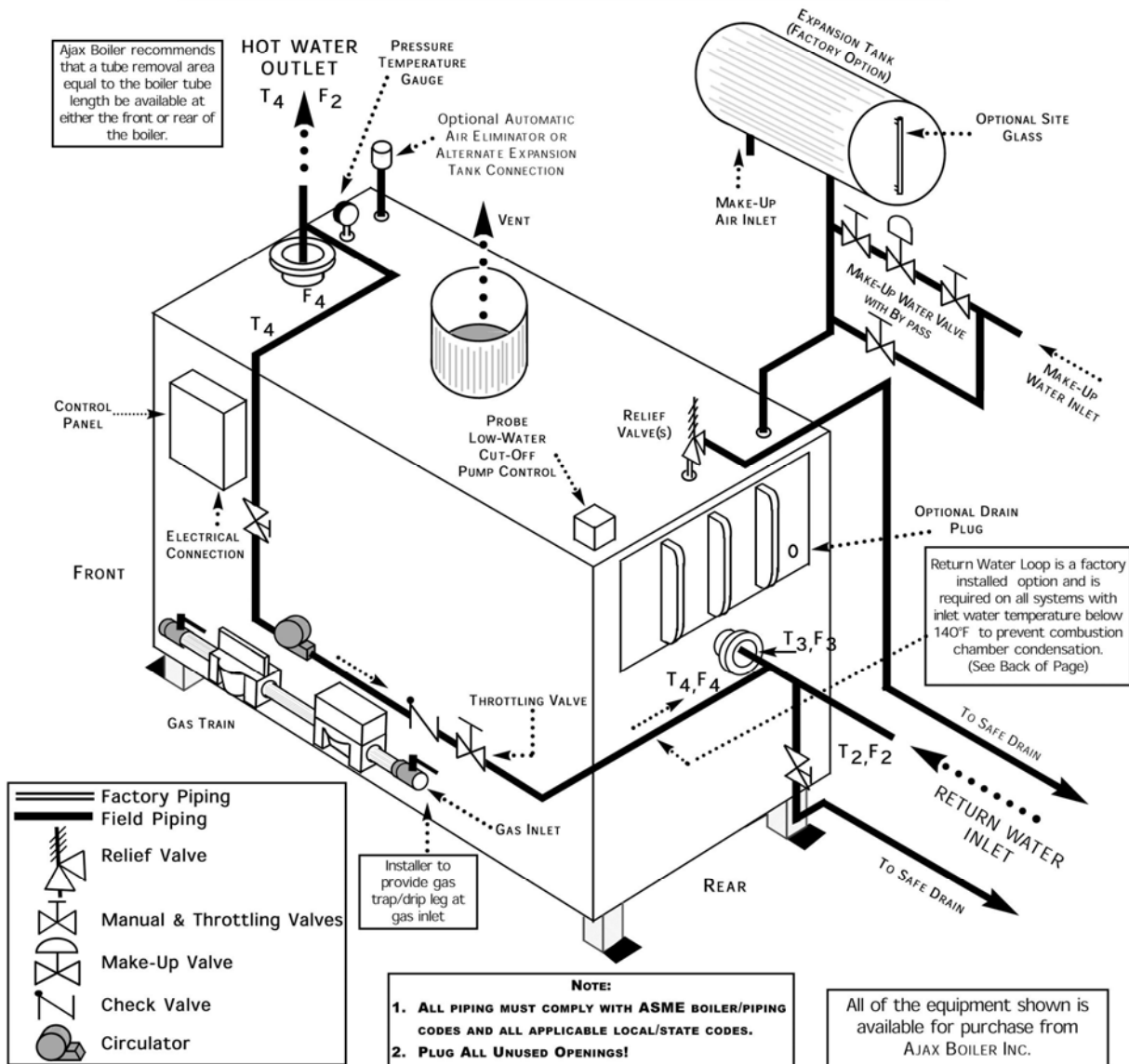

## Installation of Boiler with Refrigeration System

---

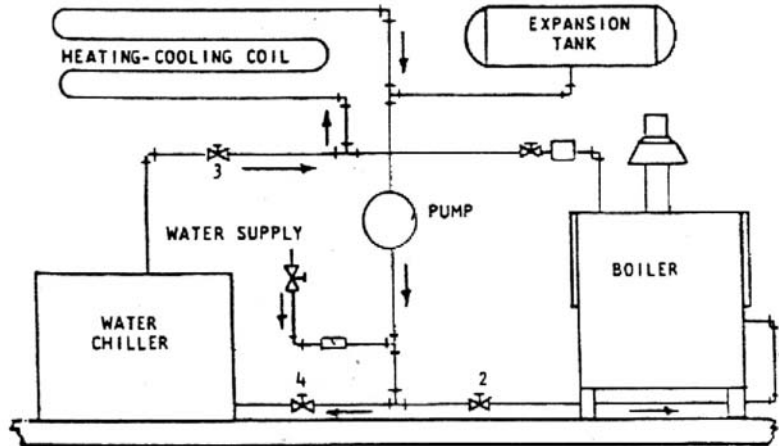

The boiler, when used in connection with a refrigeration system, must be installed so the chilled medium is piped in parallel with the boiler with appropriate valves to prevent the chilled medium from entering the boiler.

1. Install valves 1, 2, 3 and 4. Valves 1, 2, 3 and 4 may be manual or automatic.
2. Close valves 1 and 2 when operating water chiller.
3. Close valves 3 and 4 when operating boiler.
4. Water supply valve remains open at all times.

**Note:** When hot water heating boilers are connected to heating coils located in air handling units where they may be exposed to refrigerated air circulation, the boiler piping system shall be equipped with flow control valves or other automatic means to prevent gravity circulation of the boiler water during the cooling cycle.

## Water Treatment

---

We, the manufacturer of your boiler, wish to call to your attention to the necessity for a sound approach to the broad problem of boiler feed water treatment.

Boilers used for space heating purposes only, operate with a closed system of piping in which all of the boiler water is brought back to the boiler. Under these conditions, very little raw makeup water is added to the system. Unless there are system leaks, only a small amount of makeup is required and there is little need for attention to the problem of feed water treatment. Heating boilers are subject to idle periods during the warmer months of a year. Protection of such idle boilers to prevent corrosion should be considered. Such protection can be provided in several ways and can be recommended by a qualified feed water treatment service or chemical supply company in your area.

Makeup water continuously introduces contaminants; scale forming solids, corrosive minerals and oxygen, which is the primary cause of corrosion, in both water and steam boilers. The application of your boiler system, the condition of your boiler system and its operation should be carefully considered. For example, during initial operating periods of a new or a remodeled boiler system, all or a large amount of the water may be wasted. There are other reasons for water losses such as piping leaks, a faulty relief valve, blow down, summer drainage, etc. Whenever appreciable amounts of raw makeup water are continuously added to your system, we recommend that the problem be brought to the attention of a qualified water consultant.

Boiler water treatment means more than just scale prevention. It actually includes:

1. The kind and control of the chemical treatment.
2. A suitable method of regulating the preheating and pretreatment of raw water.
3. Regulating and the method of blow down of the boiler water in amounts proportionate to the raw water makeup.

The treatment program maintains the boiler water concentration within safe and acceptable limits for longer boiler life and reduced maintenance.

The feed water treatment is dependent upon the make-up water conditions. We, the manufacturer, offer the following general guidelines for water treatment. Refer to [Quick Reference Guide](#).

The analysis for and the supervision of this treatment and control can only be handled by a qualified operator, of your own or an outside chemical service that specializes in the field.

Particular care is exercised in handling the water problems in large utility central station plants. Modern industrial boilers deserve comparable attention. All modern boilers, including the smaller industrial types, are designed with lower water storage content than was used many years ago. They operate at ratings above those employed on the boilers of yesterday. This is one of the reasons we draw your attention to the importance of the proper handling of the water problem.

Water treatment is a specialized subject that we, as boiler manufacturers, are not qualified to carry on a water treatment service. We, therefore, recommend that a qualified feed water treatment service company be used to supervise all phases of the water problem that may be encountered in your installation. This service should be picked most carefully as the prevention of trouble costs far less than the cost of repairs to equipment that has been neglected.

Final proof of any feed water treatment program is in the continued observation of its effectiveness on the waterside surfaces of the boiler. Regular internal inspection of the boiler, therefore, should become part of the maintenance program.

## Before Start-up

---

1. **Clean system:** The boiler and the entire system should be cleaned and flushed prior to filling the boiler.
2. **Fill the boiler:**
  - a.) After cleaning, fill the system with a treated water mixture according to a water treatment specialist's recommendation and to the correct system pressure. Further information can be found at [www.H2Ochem.com](http://www.H2Ochem.com).
  - b.) To prevent the boiler from becoming air bound, open the relief valve located on the top rear of the boiler and leave it open until a steady flow of water is observed. On boilers equipped with a float type low water cut-off, the top cross in the low water cut-off piping should be opened to bleed off any air that may be trapped in the piping. Once this is done, close the relief valve, and low water cut-off assembly if applicable and complete filling the system to the correct pressure.
  - c.) After filling the system, inspect all piping throughout the system for leaks. If found, make necessary repairs.
3. **Fill oil tank:** Fill the oil tank with the proper grade of oil (If applicable, Models DRFO & DRFC). If the fuel tank is below the burner level, be sure to prime the pump. If the oil pump is above the tank level, the pump should be lubricated to prevent damage by running dry. In some cases, the fuel pump may become air bound. To remove the air, remove the plug on the discharge side of the pump and run the burner until oil flows freely from the discharge. Afterwards, replace the plug and restart the burner.
4. **Additional controls:** Boilers are pre-wired at the factory. If additional controls are to be installed, care should be taken not to disturb the continuity of the existing circuit. Refer to the boiler wiring diagram and control manufacturer's instructions supplied with the boiler.
5. **Venting:** The venting will include a barometric damper (draft hoods are not approved). A wind deflecting vent cap that prevents down drafts, must be securely fastened to the vent outlet. Outdoor units will be provided with a rain cap as standard.
6. **Check factory assembled joints and head bolts:** Although the boiler pressure vessel and the gas train are pressure tested prior to shipping, often times during shipment, items may work loose. These items may include head plate nuts, relief valves and gas train assemblies. These items should be checked prior to operating the boiler and tightened. Refer to [Quick Reference Guide](#).

**Important!** The boiler gas piping and all connections should be tested for leaks before starting up the boiler. *Do not use a flame test.* It is important that you check the boiler gas train as some components may shift during transport. The boiler has been furnished completely assembled at the factory and furnished to deliver the rated capacity, as designated on the boiler nameplate. The manifold pressure must be set between the specified gas pressures recommended in the burner manual. The supply pressure to the boiler regulator must be set between the minimum and maximum pressures stated on the boiler nameplate.

## Start-up Instructions – Gas

---

**Important!** When starting up your boiler for the first time, run it at low fire for 30 minutes prior to running it at high fire. The refractory panels may contain moisture from the curing process. Running the boiler at low fire will dry out the panels. If the boiler is immediately operated at high fire, there may be a chance that the refractory will crack. A "cold" boiler should be treated the same way.

**Please see the burner operation manual for complete instructions.**

1. **Read manual:** Before attempting to start-up the boiler, read this manual in its entirety and be familiar with the details contained within.
2. **Verification:** Locate the boiler nameplate and verify the voltage, type of gas, gas pressure and regulator setting. Ensure free combustion air openings to the boiler room meet the requirements on the boiler nameplate, local codes, gas industry standards and the O&M manual. The venting will include a draft hood or barometric damper (Indoor units only). A wind deflecting vent cap that prevents down drafts, must be securely fastened to the vent outlet. Outdoor units will be provided with a rain cap as standard.
3. **Inspect:** Turn off all electric power and open the main gas valve. Smell for gas, especially around the floor. **If you smell gas, shut the main gas valve to the boiler immediately and check for piping leaks!** If you do not smell gas, go on to the next step.
4. **Operating controller:** Set the operating temperature controller to its lowest setting and the hi-limit 15°F above the operating temperature control. (Figure 1.4)



Figure 1.4

5. **Main power:** Set the main power switch and the burner panel control switch to the ON position. The burner blower motor will start and after a suitable pre-purge period (this will vary based upon the control safeguard used – usually 30 to 90 seconds). If equipped, the manual firing rate potentiometer should be set at its lowest setting.
6. **Flame:** Once flame has been established, run the boiler at low fire for ½ hour. This will evaporate the moisture in the refractory panels.
7. **Low fire run time:** After running the boiler at low fire for ½ hour, open the manual gas valves fully. Make sure the boiler operating temperature control is set at the desired output temperature.
8. **Full fire:** The boiler will continue to operate at full fire until it satisfies its set operating temperature. Once satisfied, the boiler will shut down or go to low fire if equipped.



9. **Testing:** While the boiler is running, test all interlocks and safeties. Once the boiler has reached at least 150°F, test the high limit by turning the temperature dial to its lowest setting. The boiler should shut down and lock out. To put the boiler back in operation, turn the high limit temperature setting to 15°F higher than the operating temperature setting and press the reset button on the high limit. The boiler will now resume.
10. **Testing low water cut-off:** To check the low water cut-off, push the test button located on the boiler control panel, labeled LWCO. Hold it for 5 seconds. This will produce a simulated low water shutdown. Upon release on the button, the boiler will remain locked out. The boiler will remain locked out until the low water cut-off reset button, located on the control panel, is depressed.
11. **Draft:** Stack Draft Requirements (FD), -0.02" to -0.04" Water Column.
12. **Boiler Circulation:** Proper water flow is required for water boilers; low water flow may cause overheating of the water in the boiler tubes. **Prolonged operation of the boiler under this condition may cause damage to the unit.** The most common **WARNING** sign is a knocking sound, from which the water inside the boiler tubes is flashing to steam.

### After Start-up Check List

- Has air been purged from the system?
- Has the gas line piping been checked for gas leaks?
- Have the operating and high limit temperature controls been set?
- Is the boiler inlet water temperature above 140°F?
- Is the blow fan rotating in the appropriate direction?
- Flue gas spillage and soot:** Check for spillage at the draft hood. Check for soot around the sheet metal joints. Use the smoke from a match to detect flue gas spillage. If spillage is present, determine the cause of the problem and correct it.
- Leaks:** Look for water on the floor. Check for water leaks from any part of the boiler, valves or piping.
- Supports:** Check for proper supports on the water piping and gas lines.
- Caution:** Keep flammable materials away from the boiler. In the event of the boiler overheating – shut the boiler down by (1) turning off the manual gas valve located in the gas controls manifold adjacent to the boiler and (2) turn off the electricity to the boiler.

### Shutting Down the Boiler

1. **Operating controller:** Set the operating temperature controller to its lowest setting.
2. **Burner:** Follow the instruction in the burner manual for proper shutdown.
3. **Power:** Turn off the boiler by switching the toggle switch on the control panel into the OFF position.
4. **Gas valves and oil line:** Close the main gas valve and/or oil lines.

## Start-up Instructions – oil

---

**Important!** When starting up your boiler for the first time, run it at low fire for 30 minutes prior to running it at high fire. The refractory panels may contain moisture from the curing process. Running the boiler at low fire will dry out the panels. If the boiler is immediately operated at high fire, there may be a chance that the refractory will crack. A "cold" boiler should be treated the same way.

**Please see the burner operation manual for complete instructions.**

1. **Read manual:** Before attempting to start-up the boiler, read this manual in its entirety and be familiar with the details contained within.
2. **Verification:** Locate the boiler nameplate and verify the voltage, type of gas, gas pressure and regulator setting. Ensure free combustion air openings to the boiler room meet the requirements on the boiler nameplate, local codes, gas industry standards and the O&M manual. The venting will include a draft hood or barometric damper (Indoor units only). A wind deflecting vent cap that prevents down drafts, must be securely fastened to the vent outlet. Outdoor units will be provided with a rain cap as standard.
3. **Valves:** Open all valves in the oil lines.
4. **Operating controller:** Set the operating temperature controller to its lowest setting and the hi-limit 15°F above the operating temperature control. (Figure 1.4)



Figure 1.4

5. **Main power:** Set the main power switch and the burner panel control switch to the ON position. The burner blower motor will start and after a suitable pre-purge period (this will vary based upon the control safeguard used – usually 30 to 90 seconds). If equipped, the manual firing rate potentiometer should be set at its lowest setting.
6. **Flame:** Once flame has been established, run the boiler at low fire for ½ hour. This will evaporate the moisture in the refractory panels.
7. **Low fire run time:** After running the boiler at low fire for ½ hour, open the manual gas valves fully. Make sure the boiler operating control is set at the desired output temperature.
8. **Full fire:** The boiler will continue to operate at full fire until it satisfies its set operating temperature. Once satisfied, the boiler will shut down or go to low fire if equipped.
9. **Testing:** While the boiler is running, test all interlocks and safeties. Once the boiler has reached at least 150°F, test the high limit by turning the temperature dial to its lowest setting. The boiler should shut down and lock out. To put the boiler back in operation, turn the high limit temperature

setting to 15°F higher than the operating temperature setting and press the reset button on the high limit. The boiler will now resume.

10. **Testing low water cut-off:** To check the low water cut-off, push the test button located on the boiler control panel, labeled LWCO. Hold it for 5 seconds. This will produce a simulated low water shutdown. Upon release on the button, the boiler will remain locked out. The boiler will remain locked out until the low water cut-off reset button, located on the control panel, is depressed.
11. **Draft:** Stack Draft Requirements (FD), -0.02" to -0.04" Water Column.

### After Start-up Check List

- Has air been purged from the system?
- Has the gas line piping been checked for gas leaks?
- Have the operating and high limit temperature controls been set?
- Is the boiler inlet water temperature above 140°F?
- Flue gas spillage and soot:** Check for spillage at the draft hood. Check for soot around the sheet metal joints. Use the smoke from a match to detect flue gas spillage. If spillage is present, determine the cause of the problem and correct it.
- Leaks:** Look for water on the floor. Check for water leaks from any part of the boiler, valves or piping.
- Supports:** Check for proper supports on the water piping and gas lines.
- Caution:** Keep flammable materials away from the boiler. In the event of the boiler overheating – shut the boiler down by (1) turning off the manual gas valve located in the gas controls manifold adjacent to the boiler and (2) turn off the electricity to the boiler.

### Shutting Down the Boiler

1. **Operating controller:** Set the operating temperature controller to its lowest setting.
2. **Burner:** Follow the instruction in the burner manual for proper shutdown.
3. **Power:** Turn off the boiler by switching the toggle switch on the control panel into the OFF position.
4. **Gas valves and oil line:** Close the main gas valve and/or oil lines.

## Maintenance Instructions

---

1. **Keep tubes clean:** In order to maintain high boiler efficiency and boiler life, the boiler tubes should be cleaned periodically, both inside and outside. The frequency of cleaning the inside of the boiler tubes depends on the characteristics of the water and the type of installation. When a large amount of makeup water is used, it is good practice to inspect and clean, if necessary, the inside of the tubes after 30 days. The accumulation of lime and other solids within this time will establish the criterion for how often the boiler tubes should be cleaned. On closed systems, where only a small amount of makeup water is used, the insides the boiler tubes should be examined and if necessary, cleaned at the end of the heating season. When makeup water is negligible, such as boilers connected to unit heaters or radiators, the boiler should be flushed at the end of each heating season. All water boilers should have a tee installed at the boiler inlet for draining the boiler. Clean tubes will not only ensure higher boiler efficiency but will also prevent possible damage to the boiler. The boiler should never be fired unless it is full of water.
2. **Gaskets:** Tighten gaskets during start up and periodically thereafter. Leaky gaskets will cause the use of excessive makeup water and could cause corrosion of the stud bolts. It is good practice to use a new gasket; however, if the gasket is not damaged, it may be reused. Use a soft gasket compound on both sides of the gasket. Specify boiler model number and the height and width of the boiler head plate when ordering new gaskets.
3. **Studs:** Keep studs protected from corrosion with paint or oil. Keep stud bolts tight to prevent leaky gaskets. Stud bolts will not corrode if they are kept dry and protected. Use caution in removing and reinstalling head plates. The boiler must be shut down and drained. Before removing the nuts, apply penetrating oil and allow it to set for a few minutes. Tap the head plate lightly around each stud bolt before trying to break the nut loose. Forcing the nut off could cause breakage. Use a torch to heat the nut and it will come off easier. If a torch is not available, take a cold chisel, place it across the flat of the nut, and strike several sharp blows with a heavy hammer. This should loosen the nut. If necessary, it is better to split the nut open and replace it than to break the stud off.

Should, for any reason, a stud bolt on a boiler head be broken, it can be replaced as follows: without removing the heat plate, use a slow speed drill to drill out the remaining portion of the stud. Re-drill the header and tap using a standard thread tap. Spare studs may be obtained from the factory.

4. **Controls:** Under normal conditions, controls furnished with the Ajax Boiler require very little service. It is important, however, that the controls be protected from moisture and dirt. All controls should be checked frequently to make sure that they are working properly. Turn both the operating controls and the safety controls up and down to verify that they will operate satisfactorily. The high limit control furnished with the boiler should only be used as a safety control.
5. **Power burner:** Reference the maintenance and service instruction in the burner manual.
6. **Relief valve:** Boilers are equipped with a lever type relief valve of "ASME" rated capacity. To maintain the valve in good working condition, it should be manually opened once a month on "closed" systems and once a week on "open" systems. The relief valve outlet should be piped directly to an open drain and the drain checked frequently for discharge. If the relief valve is leaking or does not operate freely, it should be replaced.

7. **Low water cut-off:** A low water cutoff is furnished to protect the boiler against damage by preventing it from operating without water. This is particularly important when the boiler is installed above the water level, i.e., on a roof. Low water level cutoffs should be checked periodically by lowering the water level in the boiler and verifying that the safety circuit opens. Float type low water cutoffs should be flushed at least once a week on "open" systems and once a month on "closed" systems (if applicable). If neglected, accumulation of sediment within the low water cutoff casing may render the control inoperative and thereby become a safety hazard. Probe low water cutoffs may accumulate deposits on the grounding element. These should be carefully cleaned.
8. **Operating control:** The operating temperature control sets the desired boiler water temperature output. To adjust the water temperature, insert a small straight screwdriver into the slotted screw hole at the front of the controller. This controller has an adjustable differential wheel under its casing.
9. **High limit manual reset:** The boiler is equipped with a manual reset high limit temperature safety designed to shut down the boiler in the event the boiler water temperature exceeds the high limit set point. The high limit should be set 15°F above the operating temperature controller.
10. **Gas pressure switches (Optional, where applicable):** The low gas pressure switch is designed to shut down the boiler if the gas supply drops below its set point. The high gas pressure switch is designed to shut the boiler down if the gas pressure exceeds its set point. Both switches will lock out and must be manually reset if tripped.
11. **Anodes:** Magnesium anodes are standard on all copper tube boilers. They will extend the life of the boiler, and must be replaced periodically. The replacement frequency can vary from six months to several years. Higher temperatures and/or higher total dissolved solid contents in the boiler water will speed electrolysis and decrease the life of the anodes. Normally, two anodes in each header are adequate for header protection. Under adverse conditions, it may be necessary to install as many as three or four anodes in each header. New anodes may be purchased from your Ajax Boiler representative.
12. **Venting system (indoor boilers):** Examine the venting system externally at least once a year for:
  - a.) Tightness of all joints and connections including the draft hood to the boiler and the vent connection from the draft hood to the stack.
  - b.) Corrosion of metal in the vent ducting.
14. **Flue gas passageways:** Inspect and clean, if necessary, at least once every five years.
  - a.) Shut off gas and turn off electric power to boiler.
  - b.) Disconnect vent pipe and remove draft hood(s) or vent cap on outdoor boilers.
  - c.) Examine flue gas passageways and the inside of the venting system for soot and corrosion.
  - d.) If cleaning is needed, open front door, remove main burners, and cover burner orifices and pilot burner with a waterproof covering.
  - e.) Protect controls, electrical, etc. with waterproof covering.
  - f.) Clean tube bundle through vent opening(s) at top of boiler using a water or steam hose. Clean out and reassemble boiler after cleaning.

**Note:** If any parts need tightening or replacement, consult a qualified serviceman.

*It is highly recommended that an operator's log be kept as a record of boiler readings as a way of tracking operational changes that may affect warranty and/or boiler reliability.*

## Maintenance Intervals

### Daily Maintenance

1. **Check water level:** An unstable water level can indicate several problems such as excessive solids or water treatment, contamination from oil, overload or control malfunction. Ensure there is water in the gauge glass (if applicable) every time you enter the boiler room.
2. **Check combustion visually:** Look at the flame to see if anything has changed. Changes may be an indication that a problem is developing.
3. **Treat water according to the established program:** Add chemicals and take tests as outlined by your chemical feed water consultant.
4. **Record boiler operating pressure and temperature:** An excessive steam or water temperature drop will alert you to excessive loading on the boiler.
5. **Record feed water pressure and temperature:** A change in pressure or temperature may indicate a problem is developing with your feed pump(s), deaerator or packaged feed system.
6. **Record stack temperatures:** Changes in stack temperatures could indicate the boiler is sooting, scaling or there is a problem with baffles or refractory.
7. **Record oil-atomizing pressure (if applicable):** Changes in pressure could have an effect on combustion in the boiler.
8. **Record gas pressure:** Changes in pressure could have an effect on combustion in the boiler and indicate a problem in the gas delivery system.
9. **Check with general boiler/burner operation personnel:** Has anything changed from the day before? If so, why?
10. **Record boiler water supply and return temperatures:** On hot water boilers, record these temperatures to assist in detecting system changes. Return temperatures below 140°F will cause the boiler to condense.
11. **Record makeup water usage:** Excessive makeup water could be an indication of system problems (leaks) in both steam and hot water systems.
12. **Check auxiliary equipment:** There is a vast difference between "is it running" and "is it running properly." Take nothing for granted, as auxiliary equipment can shut down your operation.

### Weekly Maintenance

1. **Check for tight closing fuel valves:** Check to ensure fuel does not flow through the fuel valve(s) when the burner is shut off.
2. **Check fuel and air linkage:** Check to ensure that all set-screws on linkages are tight and securely holding the linkage in place (Forced Draft boilers).
3. **Check indicating lights and alarms:** Check for burned out or loose light bulbs. In addition, check to ensure the alarm bell sounds on the appropriate shut down condition.
4. **Check operation of water level controls:** Stop the boiler feed pump and allow the control to stop the boiler under normal low fire conditions.
5. **Check for leaks, noise, vibration, unusual conditions, etc.:** Checking for these items, is a cost-effective way to detect system operational changes. Small problems can be corrected before they become large problems.
6. **Check operation of all motors:** By developing a routine, any change in operation or bearing temperature will usually be caught in time to avoid a failure.
7. **Check the flame scanner assembly (if applicable):** Using the appropriate meter, check the flame signal strength at the program relay flame amplifier. Ensure the scanner assembly is clean and dry.

8. **Check gauge glass:** Ensure there are no scratches or etching in the glass or leakage around the package.

### Monthly Maintenance

1. **Inspect burner operation:** Do a visual inspection of the pilot flame and main burner flame throughout the firing range.
2. **Analyze combustion:** Take the flue gas analysis over the entire firing range, comparing the combustion analysis and stack temperature reading with the previous month.
3. **Check cams (Power burners):** Inspect the cam springs for scoring, tightness of set-screws, free movement, alignment of cam followers and other related parts.
4. **Check for flue gas leaks:** Ensure something hasn't changed in the breaching, stack or overall system that allows flue gas to be drawn into the boiler room.
5. **Check boiler blow down:** Review boiler blow down to determine that a waste of treated water is not occurring. Check water treatment and testing procedures with your feed water consultant.
6. **Check all combustion air supply inlets:** Ensure sufficient combustion air is being supplied to the boiler room and burner.
7. **Check all filter elements (oil, gas and air):** Clean or replace as needed. On "self-cleaning" filters, make certain that impurities are flushed or discharged from filter body.
8. **Check the fuel system:** Make sure certain strainers, vacuum gauges, pressure gauges and pumps are properly cared for.
9. **Check lubrication:** Verify lubrication requirements of all bearing supported equipment. Do not over-lubricate electric motors.

### Semi-Annual Maintenance

1. **Clean low water cut-off(s):** Remove the head assembly or probes, inspect and clean out any sediment or contamination in the column or piping. Determine why sediment or contamination condition exists.
2. **Pre-heaters:** Check oil pre-heaters by removing the heating element and inspect for sludge or scale.
3. **Repair refractory:** Repair all cracks and fill in gaps.
4. **Clean oil pump strainer and filter:** Ensure they are not plugged, thus reducing the flow of the required oil to the burner.
5. **Reset combustion:** The entire combustion process should be carefully checked, O<sub>2</sub> readings taken and necessary burner adjustments made. Make certain readings are recorded and used as a basis of comparison for future tests. Combustion adjustments should only be made by those thoroughly familiar with all aspects of burner adjustments and combustion.

### Annual Maintenance

1. **Clean fireside surfaces:** Clean fireside surfaces by brush or use a powerful vacuum cleaner to remove soot. After the cleaning process, and if the boiler is to be left open, it is advisable to spray all fireside surfaces with some type of corrosion preventative.
2. **Clean breaching:** Inspect breaching, stack, and remove any soot build-up.
3. **Clean waterside surfaces:** Remove all head plates and inspect tubes. Inspect water columns, tee and float assemblies from water columns. Thoroughly wash all waterside surfaces.
4. **Check gauge glass for possible replacement:** If internal erosion at water level is noted, replace with new glass and gaskets.
5. **Remove and recondition safety valves:** Have them reconditioned by an authorized safety valve facility. The safety valve is an important device yet possibly receives less attention than any other device.

6. **Boiler feed pumps:** Strainers should be reconditioned. Feed-pump elements wear and must be replaced. Sometimes a review of the condensate return system and chemical feed arrangement will reveal causes of short pump life.
7. **Chemical feed systems:** Chemical feed systems should be completely emptied, flushed and reconditioned. Metering valves or pumps should be reconditioned at this time.
8. **Tighten all electrical terminals:** All terminals should be checked for tightness, particularly on starters and moveable relays.
9. **Check linkages:** Check to ensure the linkage ball connectors have not worn out. Worn connectors can cause inconstancy in the linkage movement and result in unrepeatability of excess air levels in the combustion process.

## Removing and Sealing The Manway Access Door

Every Ajax Boiler, size 50HP and up, includes a bricked access door to the combustion chamber on the left side of the boiler. This manway entrance provides access to the combustion chamber, the burner nozzle and the first row of boiler tubes for ease of maintenance. Boilers under 50HP will have front-hinged door access.

### Opening The Manway

1. Remove the sheet metal plate covering the manway access. The plate is sheet metal screwed to the side of the boiler.
2. Remove the fiberglass insulation, the Fibrex board (if applicable) and the fitted refractory panel. These items have been laid in the access hole. Once these items have been removed, this will give access to the refractory brick set and mortared in place.



3. Use a chisel and hammer or a saber saw to carefully break the brick from the pre-cast refractory panels. **Do not** hit the bricks with a hammer, as this may damage the surrounding refractory panels.





### **Closing The Manway**

1. Remove all loose debris around the manway opening.
2. Using a high temperature refractory brick, fill in the opening. Some of the bricks will require cutting in order to fit. Set the bricks in loosely first to guarantee a perfect fit. The bricklayers must be staggered.
3. Once the bricks have been arranged so they fit, remove them and reinstall each brick with a high temperature mortar. Install each brick until the manway hole is covered.
4. After the bricks have been placed, trowel a ½" layer of mortar to the backside of the bricks to seal.
5. Reinstall the refractory panel, Fibrex board (if applicable), the fiberglass insulation and the sheet metal panel.

## Adjusting Gas Pilots On Power Flame C & J Burners

---

### Scanner Pilot

1. Ensure gas pressure does not exceed pilot regulator specifications
2. Set pilot gas pressure at 1 ½" to 4" WC. Best flame signal at test tee on pilot.
3. Ensure there is an adequate earth ground.
4. Check for proper electrode gap and depth in pilot head. See [Burner Manual](#).
5. Check for strong blue spark from ignition transformer.
6. Ensure air holes in pilot body are unobstructed.
7. Clean pilot electrode of soot.
8. Check for pilot pressure at main flame light off. If pilot pressure drops at the point when the main gas valve opens, check for proper gas supply. Gas line may be undersized or under-pressured.
9. Adjust pilot to improve signal.
10. Check boiler draft. High draft may affect pilot reliability.

### Flame Rod Pilot

1. Ensure flame rod is clean.
2. Make sure all grounding points on pilot are clean.
3. Check for proper electrode gap and depth in pilot head. See [Power Flame Manual](#).
4. Check for strong blue spark from ignition transformer.
5. Flame sensing wire resistance should be near 0 ohms.
6. Ensure static inlet gas pressure does not exceed pilot regulator.
7. Set pilot gas pressure at 1 ½" to 4" WC. Best flame signal at test tee on pilot.
8. Check for pilot pressure at main flame light off. If pilot pressure drops at the point when the main gas valve opens, check for proper gas supply. Gas line may be undersized or under-pressured.
9. Ensure air holes in pilot body are unobstructed.
10. Check the draft through the boiler in the off-cycle, pre-purge and pilot flame establishing pressure. High draft will affect pilot reliability and can cause pilot failures. Reduce draft via barometric damper or other draft control device.

## Trouble Shooting Guide

---

The following is a list of items that can cause boiler performance problems if not installed correctly.

**Available combustion air:** Normal Conditions: 1 sq. in. open area per 1000 Btu/hr. Note: This must be open area between louvers.

**Stack draft:** Normal Conditions: Forced Draft: Balanced draft, -0.02" to -0.04" WC.

**Combustion Chamber Pressure:** The combustion chamber pressure should not exceed 0.25" WC on "DRF" boilers and should not exceed +0.50" WC on "DRF" boilers with lox NOx burners installed by factory.

**Fuel pressure:** See [Burner Manual](#).

**Inlet water treatment, flow, and/or temperature:** Minimum inlet water temperature without boiler recirculator line = 140°F

The following are common problems with possible causes and solutions.

1. **Nuisance flame failures:** See [Burner Manual](#).
  
2. **Boiler not putting out enough heat:** The main reason a boiler will not put out enough heat is usually due to there not being enough gas reaching the burners. Check the following:
  - a.) Have you been able to accurately measure the gas flow (oil) rate at the meter?
  - b.) What is the gas pressure at the burner manifold?
  - c.) What is the inlet gas pressure, while the burner is firing? This number will be lower than when the burner is not firing?
  - d.) Review combustion report, if the boiler is under fired, there should be too much Oxygen in the stack gases?
  - e.) Is the boiler at altitude? If yes, has it been derated?
  
4. **Boiler is sooting up:**
  - a.) **Condensate:** Check the boiler's flue gas using a combustion analyzer and compare those to the ideal combustion list. Refer to [Ideal Combustion Rate](#). A high percentage of CO in the combustibles is an indication of a sooting problem.  
  
Running the boiler in a condensing mode with inlet water temperatures below 140°F. When this happens, it will "rain" down on the burners and appear to be leaking. The boiler will subsequently soot up.
  - b.) **Insufficient gas/air ratios:** See [Burner Manual](#).
  - c.) **Check Start-up or Combustion report:**
  - d.) **Combustion:** Open a door to the boiler room. Any improvement? If so, there is not enough combustion air in the boiler room.
  - e.) **Pressurization:** Is the room pressurized? Is there other equipment in the room? Is there an extractor fan in the room?
  
5. **My boiler is leaking:** Sometimes boilers appear to be leaking when they are actually operating in a condensing mode. To prevent condensing, inlet water temperature should be 140°F or higher.

## Condensation

During startup conditions, when the boiler water temperature is below 140°F, condensation will occur. Condensation will stop when the return boiler water temperature exceeds 140°F. **Water tube boilers, including the Ajax Boiler, should not be operated at water inlet temperatures below 140°F.** Prolonged operation of the boiler under condensation conditions will cause damage to the boiler. If the boiler application requires inlet water temperatures below 140°F, a boiler recirculation system must be installed so that the cold inlet water is mixed with hot boiler water in a ratio to ensure that condensation does not occur.

## Cold Start-ups

Too many cold startups will be evidenced by rust stains on the refractory inside the boiler and around the boiler doors. If condensation occurs regularly, eventually the boiler tubes and firebox area may rust apart and collapse. Frequent shutdowns of the heating system can endanger the boiler life expectancy. With a water boiler, maintain at least the minimum inlet water temperature recommended (140°F). If an outdoor reset control is used, the controls must be arranged so that the boiler never falls below the recommended water temperature.

## Soot

No matter what kind of fuel is used (gas, oil, LPG), soot and scale deposits will accumulate on the outside of the boiler tubes. If the tubes aren't cleaned regularly, boiler efficiency will be sacrificed and fuel will be wasted. Soot has excellent insulating properties, which can result in a tremendous heat loss and increased fuel consumption.

### CAUTION:

1. Check daily to be sure that boiler area is free and clear of combustible materials, gasoline, solvents, and other flammable vapors, liquids or materials.
2. Check daily to be sure that the flow of combustion and ventilating air to the boiler is not obstructed.
3. If the boiler overheats, shut it down immediately by (1) turning off the manual gas valve located on the boiler and (2) turning off the electric power to the boiler.

For other trouble shooting issues, please reference the specific control sheets included in this manual.

## Quick Reference Guide

---

Head Plate Torque Requirement	
5/8" studs	90ft.lbs
3/4" studs	150ft.lbs
7/8" studs	240ft.lbs
Stack Draft Requirements (FD)*	-0.02" to -0.04" Water Column
Manifold gas pressure (Nat. Gas)	3.5" to 4" Water Column
Manifold gas pressure (LPG)	11" Water Column
Minimum Inlet Water Temperature	140°F
Water Treatment	
Hardness	Less than 0.3 ppm
PH Value	7.2 to 9.5
Suspended solids	Less than 10 ppm
Dissolved solids	Less than 3000 ppm
Oxygen before scavenger addition	Less than 0.2 ppm
Oxygen after scavenger addition	Less than 0.007 ppm
Total alkalinity	Less than 350 ppm

\* Draft range is provided as a guide. Adjustment of Forced Draft burners for smooth operation, burner performance and proper combustion is one of the primary start up and maintenance requirements for a successful installation

### Replacement Parts

Ajax Boilers have been manufactured since 1924. In the course of these years, many improvements have been incorporated in the design of our boilers. Information on the Ajax Boiler is subject to change without notice as design improvements continue. Ajax Boiler maintains a complete equipment list for each boiler filed by boiler serial number. In order for us to give prompt service and to ensure that correct parts are supplied, please be sure and supply the boiler model and serial number.

1. **Head Plate Gaskets:** Specify the height and width of the boiler head plate with the model and serial number when ordering.
2. **Anodes:** Give boiler model and serial number when ordering.
3. **Burners:** When ordering burner parts advise boiler model, serial number of both boiler and burner.
4. **Boiler Tubes:** All Ajax Boilers are equipped with 2" O.D. steel or copper tubes. These tubes are rolled and flared into a tube sheet with a minimum thickness of 1/2". Furnish overall boiler length, taken at the top of the jacket, with the model and serial numbers when ordering boiler tubes.
5. **Studs:** If a stud on a boiler header should break, see stud replacement in the service instructions.

### Material Safety Data Sheets

Some of Ajax Boiler products contain materials that have been recognized as posing health risks. Material Safety Data Sheets for these materials are available from your local Manufacturer's rep. When requesting this information, be sure to have the model number and serial number available.

If you do not know who your local Manufacturer's Rep is, you can find out by logging into the [www.ajaxboiler.com](http://www.ajaxboiler.com) website, and clicking on the Representative tab found in the table of contents.

© Ajax Boiler Inc.  
2701 S. Harbor Blvd.  
Santa Ana, CA 92704  
Parts: 714.437.9050  
[www.ajaxboiler.com](http://www.ajaxboiler.com)  
email: [info@ajaxboiler.com](mailto:info@ajaxboiler.com)



## AJAX BOILER INC. - ACE BOILER INC. FACTORY LIMITED WARRANTY POLICY

The Ajax Boiler Factory limited warranty provides assurance that all products are free from manufacturer's defects at the time of shipment and meet specifications and performance described in the product literature.

It is important to understand the difference between a factory warranty and an installed warranty. There are many factors that can occur to the products after they are shipped that the company has no control over and can not fully verify. These include:

1. Hidden damage during the shipping.
2. Handling damage.
3. Damage during storage.
4. Installation conditions.
5. Other unknown variables in the system design: maintenance, pulsation and vibrations.

The installed warranty is the responsibility of the architect, specifying engineer, contractor and/or owner who jointly have control over the application, installation, location, operating and maintenance conditions.

The Ajax Boiler Inc. warranty excludes extended liabilities. Extended liability typically occurs when products are installed without proper drainage, flooding containment or when safety devices are not tested and repaired or replaced when needed.

Product problems are often caused by the condition of the water, the lack of water treatment and/or the improper treatment of the water, insufficient combustion air, improper draft conditions, bolts not re-tightened, pipes not flushed and cleaned of oil, metal chips, rags, vibration and pulsation etc. These are installation, operating and/or maintenance conditions that are beyond the seller's responsibility and are not covered by the factory warranty, but may be covered by the installer's warranty.

The factory warranty covering company products is based upon extensive product development and testing. Combustion products under go certification testing and approvals to Underwriters Laboratory (UL) standards. Auditing of the production of combustion products is conducted by a nationally recognized testing laboratory.

Pressure vessel products are designed and manufactured to American Society of Mechanical Engineering (ASME) and National Board (NB) Design standards. Design reviews, factory product manufacturing quality inspections and testing are carried out by a third party National Board authorized inspection agency.

Ajax Boiler Inc. products have proven themselves in service for over 85 years which indicates that the company products perform exceedingly well when normal installation, operating and maintenance conditions exist.

The following is a review from the terms and conditions of sale. Also included in paragraph two, below, is the Ajax Boiler Inc. non-conformance policy.

1. Ajax Boiler Inc. warrants its products against defective material and/or workmanship only. The warranty does not apply to operational failures, electrical failures, gasket leaks, and/or other malfunctions caused by improper application, installation and/or maintenance.
2. It is the buyer's responsibility to inspect and accept the product, when received, as conforming to their purchase order, specifications and approved drawings. All claims for non-conformance, errors, shortages, etc. must be made within 10 days after receipt of the shipment.
3. Ajax Boiler Inc. do not provide a warranty or guarantee, express or implied, in any manner, form, usage of trade, merchant-ability or fitness which extend beyond the product description and quotation.
4. Ajax Boiler Inc. liability is limited to the factory repair or replacement of warranty failures, or non-conformance, upon the return of the product to the factory.
5. Ajax Boiler Inc. is not liable for any direct or consequential damages.
6. The Ajax Boiler Inc. warranty is based upon section 23161(2) of the uniform commercial code and is printed in the terms and conditions of sale which is referenced in every quotation, on the back of sales order acknowledgements and invoices. It is legally correct and is an industry standard policy.

**AJAX BOILER INC. - ACE BOILER INC.**

# **WARRANTY**

## **LIMITED THERMAL SHOCK**

In addition to our standard one (1) year warranty against defective parts and workmanship, Ajax Boiler Inc. provides the following guarantee with all commercial hot water, forced circulation, space heating boilers:

Ajax Boiler Inc. guarantees this new boiler pressure vessel for twenty (20) years after date of installation from damage due to thermal shock. Thermal shock occurs when cold makeup water, up to 150°F less than the boiler water outlet temperature, is added directly into the boiler while the boiler is operating within the normal temperature range from 140°F to 250°F with a temperature rise from 20°F to 40°F. This guarantee shall cover damage to the boiler tubes, tube headers, and tube sheets when such damage is attributed to unequal expansion, poor circulation and/or other causes quite often described as "thermal shock". This guarantee does not cover damage or failures that can be attributed to corrosion, condensation, scale, boiler treatment chemicals, dirt accumulation, low water conditions, or any other abnormal operating conditions.

**The liability of Ajax Boiler Inc. is limited solely to the replacement of the complete pressure vessel, with tubes, if found by our inspection to be damaged by thermal shock. In no event shall Ajax Boiler Inc. be held liable for replacement labor charges or for freight or handling charges.**



2701 South Harbor Blvd.  
Santa Ana, California 92704  
United States  
Tel. (714) 437-9050  
Fax (714) 437-9060  
<http://www.ajaxboiler.com>  
[mail@ajaxboiler.com](mailto:mail@ajaxboiler.com)

AJAX BOILER INC. - ACE BOILER INC.  
LIMITED

# WARRANTY

Ajax Boiler Inc. provides a limited warranty on its products against **defective material and/or workmanship only**. This limited warranty is not applicable to operational failures, electrical failures, gasket leaks, wear or malfunctions caused by improper application, installation, and/or maintenance.

Product Period - The following Limited Warranty period are from date of shipment:

**Boiler Pressure Vessels:** One year.

**Carbon Steel Tank and Heat Exchanger Pressure Vessels:** One year.

**Stainless Steel Tanks:** Three years.

**Boiler Copper Fin Coils:** Three years.

**Single-wall or Double-wall Tank/Exchanger Coils:** One year.

**Single-wall or Double-wall Mini-Packs™:** One year.

**Atlas Series Condensing Boiler:** One year.

**Linings:** (Pro-rated Warranty)

In Section VIII Tanks: Glass 30" dia. and above (Five years).

Glass 24" dia. and under (One year).

Cement (Five years).

Pre-Krete (Ten years).

In Section IV Tanks: Glass (One year).

**Controls:** Components manufactured by other than Ajax Boiler Inc. such as controls, instruments, forced draft burner, etc., provided with the boilers and packaged products are not covered by the Ajax Boiler Inc. Warranty. However, Ajax Boiler Inc. extends to the customer the same warranty provided by the manufacturer to Ajax Boiler Inc. The customer shall receive the full benefits of adjustments made to Ajax Boiler Inc. by the manufacturer.

Any claim for adjustment under this limited warranty must be made within the warranty period. Ajax Boiler Inc.'s liability shall be limited to factory repair or, at Ajax Boiler Inc.'s option, replacement of all parts which, upon test and examination by Ajax Boiler Inc., prove to be defective material and/or workmanship and within the above limited warranty. If required by Ajax Boiler Inc., parts which are claimed to be defective must be promptly delivered to the Ajax Boiler Inc. facility, transportation charges prepaid. This warranty does not cover the cost of labor, removal, or installation of the warranted item during the limited period.

This warranty is limited to the above and applies only for the period set forth. Ajax Boiler Inc. will not be liable for any loss damage, direct, incidental or consequential damages of any kind, whether based upon warranty, contract, negligence or strict liability and arising in connection with the sale, use or repair of the products. Ajax Boiler Inc.'s maximum liability shall exceed the contract price for the product's merchantability or fitness for any particular purpose and in no event shall be held responsible for any consequential damages.

For complete Limited Warranty conditions see Section G and H under terms and condition of sale.

Ajax Boiler Inc., also doing business as Ace Boiler Inc., is referred to herein as Ajax Boiler Inc.



2701 South Harbor Blvd.  
Santa Ana, California 92704  
United States  
Tel. (714) 437-9050  
Fax (714) 437-9060  
<http://www.ajaxboiler.com>  
[mail@ajaxboiler.com](mailto:mail@ajaxboiler.com)



**AJAX BOILER INC. - ACE BOILER INC.**

# **WARNING**

## **PRODUCT SAFETY NOTICE**

**AJAX BOILER AND WATER HEATER PRODUCTS OPERATE AT HIGH TEMPERATURE AND PRESSURES  
AND NOT FOR INSTALLATION ON COMBUSTIBLE FLOORING.**

- Before using this product, read and understand instructions. Save these instructions for future use.
- Before servicing, to prevent serious burns or injury, the boiler and water heater products must be cooled to less than 80°F (27°C) and the pressure must be 0 psi (0 bar).
- Turn off the electrical power before making electrical connections to prevent electrical shock.
- These products must be placed in a controlled location where untrained or unqualified personnel cannot access the operating or safety controls, must not be able to come in contact with high temperature or high pressure parts and must not perform maintenance or demolition work.
- All work performed must be by qualified properly equipped personnel trained in the proper application, installation, and maintenance or demolition of plumbing, steam, and electrical equipment and/or systems in accordance with all applicable codes and ordinances.
- Ajax Boilers and Water Heaters are complete package units with safety and operating controls and are constructed with non ASBESTOS materials. Any replacement gaskets, refractory, insulation, etc used must not contain Asbestos.
- No additional insulation is required on the Boilers and Water Heaters.
- Additions or replacement of insulation on any connecting pipes or accessories to the Boilers and/or Water Heaters must be of "NON-ASBESTOS" and contain only non-hazardous materials.
- Crystalline Silica, a material known to cause cancer, may be encapsulated in some refractory or insulation materials and must be handled only by authorized trained personnel. Crystalline Silica as used is encapsulated and is not harm full in this form. Care must be taken during removal or replacement of refractory or insulation to remove it in bulk form and avoid generation or inhalation of dust. Removal must be properly performed by trained, qualified and equipped personnel. This is also true of Asbestos not contained in Ajax products but may be otherwise contained in replacement materials or parts, in connecting piping or other nearby products.
- All safety and operating controls must be set within the specified operating limits and tested periodically to assure proper operation. All limit and operating controls must be installed in series on the boiler.
- Connect drain pipes to a safe drain to prevent serious personal injury from relief valve discharge and or from boiler blow down discharge.
- After installation, check for proper operation of all limit and operating controls before leaving the site.
- Perform scheduled and annual inspections including checking Controls for proper calibration and performance.

**Failure to follow these warnings, to allow access by unauthorized persons and the use of non-properly trained and equipped personnel in the operation, service, modification, removal or demolition of these products or replacement of parts with non-authorized factory non-asbestos materials could cause damage, personal injury or death.**



2701 South Harbor Blvd.  
Santa Ana, California 92704  
United States  
Tel. (714) 437-9050  
Fax (714) 437-9060  
<http://www.ajaxboiler.com>  
[mail@ajaxboiler.com](mailto:mail@ajaxboiler.com)

**For Hot Water Boiler Applications**

Job Name \_\_\_\_\_ Contractor \_\_\_\_\_  
 Job Location \_\_\_\_\_ Approval \_\_\_\_\_  
 Engineer \_\_\_\_\_ Contractor's P.O. No. \_\_\_\_\_  
 Approval \_\_\_\_\_ Representative \_\_\_\_\_

**Series 174A-740**  
**ASME Water Pressure Relief Valves**  
**for Pressure Protection of Hot Water Heating Boilers**  
**Sizes: 3/4" through 2" (20 - 50mm)**

**Series 174A**  
 Bronze body safety relief valves for pressure protection only of all types of hot water heating boiler equipment. Pressure range 30 to 150 psi (2 - 10 bars) with corresponding high ratings from 650,000 to 14,370,000 BTU/hr. Female inlet and outlet connections. Sizes 3/4" to 2" (20 to 50mm).

**Series 374A**  
 Iron body with forged bronze inlet, 550,000 BTU/hr rating. Size 3/4" (20mm) only.

**Series 740**  
 Iron body with expanded outlets for hot water space heating boilers. Pressure range 30 to 75 psi (2 to 5 bars) with corresponding high ratings from 925,000 to 10,700,000 BTU/hr.

**FEATURES**

- Seat located above drain; water can't be trapped and sediment can't foul seat.
- Non-mechanical seat-to-disc alignment will not stick or freeze.
- Water seal of high temperature resisting material isolates spring working parts from water during relief.

**SPECIFICATIONS**

**Boiler Relief Valves**  
 An ASME Section IV certified pressure relief valve shall be installed on each boiler as noted. The valve shall have a BTU rating in excess of the BTU rating of the boiler's heating output. Each hot water space heating boiler shall be equipped with a pressure relief valve set to relieve below the maximum boiler pressure. The valve shall feature a raised seat and non-mechanical disc alignment. Working parts and spring shall be isolated from any discharge by a high temperature resistant material. Valve shall be a Watts 174A or 740 Series.



Series 740

Series 174A

**OPERATION**

As thermal expansion conditions develop, pressure builds up to the setting of the relief valve. This will cause discharging of small quantity of water.

Should operating controls fail, permitting runaway firing, the boiler water may reach steam temperatures. The valve will then open to discharge steam at the rate or faster than the boiler can generate it, thus restoring system pressure to a safer level.

**Important:** The discharge line must be the same size as the valve outlet, and must pitch downward from the valve to a safe place for disposal.

Valve lever must be tripped at least once a year to insure that waterways are clear. This device is designed for emergency safety relief and shall not be used as an operating control.

Watts product specifications in U.S. customary units and metric are approximate and are provided for reference only. Watts reserves the right to change or modify product design, construction, specifications, or materials without prior notice and without incurring any obligations to make such changes or modifications on Watts products previously or subsequently sold.



Water Products Division • Safety & Control Valves

**MATERIALS**

Series 174A

- Bronze body construction
- Nonmetallic disc-to-metal seating

Series 740

- Iron body construction
- Nonmetallic disc-to-metal seating

**PRESSURE - TEMPERATURE**

**Series 174A**  
 Pressure range: 30 psi to 150 psi (2 to 10 bars) with corresponding high BTU/hr ratings from 650,000 to 14,370,000 BTU/hr.  
 Maximum Temperature: 250°F (121°C).

**No. 374A**  
 Pressure range: rated up to 550,000 BTU/hr at a 30 psi (2 bars) setting only.

Series 740

Pressure range: 30 PSI to 75 psi (2 to 5 bars) with corresponding high ratings from 925,000 to 10,700,000 BTU/hr.  
 Maximum Temperature: 250°F (121°C).

**STANDARDS**



Tested and rated by A.S.M.E. National Board of Boiler and Pressure Vessel Inspectors.  
 Meets Military Spec. MIL-V-18634B, Type I, Class 3A, Style A (Bronze Body), Style B (Iron Body).

**CAPACITY**

BTU/hr Steam Pressure Discharge Capacities  
 As tested and rated by the National Board of Boiler and Pressure Vessel Inspectors

Series 174A

Set Pressure psi	3/4" x 3/4" Model M3	1" x 1" Model M1	1 1/2" x 1 1/2" Model M1	1 1/2" x 1 1/4" Model M1	1 1/2" x 1" Model M1	2" x 2" Model M
30	2,07	650,000	1,005,000	1,682,000	1,788,000	2,020,000
33	2,27	695,000	1,075,000	1,788,000	1,916,000	2,150,000
35	2,41	725,000	1,125,000	1,877,000	2,010,000	2,250,000
36	2,48	740,000	1,145,000	1,916,000	2,071,000	2,310,000
40	2,76	800,000	1,240,000	2,071,000	2,249,000	2,490,000
45	3,10	875,000	1,365,000	2,265,000	2,459,000	2,720,000
50	3,45	950,000	1,470,000	2,459,000	2,690,000	2,950,000
55	3,79	1,025,000	1,560,000	2,653,000	2,930,000	3,190,000
60	4,13	1,100,000	1,620,000	2,847,000	3,175,000	3,435,000
65	4,58	1,175,000	1,695,000	3,041,000	3,425,000	3,680,000
70	4,82	1,245,000	1,855,000	3,235,000	3,680,000	3,930,000
75	5,17	1,320,000	2,065,000	3,429,000	4,125,000	4,170,000
80	5,51	1,400,000	2,165,000	3,605,000	4,360,000	4,625,000
85	5,86	1,470,000	2,285,000	3,817,000	4,590,000	4,980,000
90	6,60	1,540,000	2,400,000	4,055,000	5,060,000	5,330,000
95	6,55	1,620,000	2,520,000	4,295,000	5,525,000	5,970,000
100	6,89	1,695,000	2,635,000	4,595,000	6,000,000	6,600,000
105	7,23	1,770,000	2,825,000	4,787,000	6,480,000	7,230,000
110	7,58	1,845,000	2,965,000	4,981,000	6,965,000	7,860,000
115	7,92	1,920,000	3,100,000	5,175,000	7,450,000	8,490,000
120	8,27	1,995,000	3,270,000	5,370,000	7,940,000	9,120,000
125	8,61	2,070,000	3,415,000	5,564,000	8,430,000	9,750,000
130	8,96	2,145,000	3,530,000	5,764,000	8,920,000	10,380,000
135	9,30	2,220,000	3,645,000	5,958,000	9,410,000	11,010,000
140	9,65	2,295,000	3,855,000	6,146,000	9,900,000	11,640,000
145	9,99	2,370,000	3,860,000	6,146,000	9,900,000	11,640,000
150	10,34	2,445,000	3,795,000	6,340,000	7,630,000	14,370,000

Series 740

Set Pressure psi	3/4" x 1" Model M3	1 1/2" x 1 1/2" Model M1	1 1/2" x 1 1/4" Model M1	1 1/2" x 1" Model M1	2" x 2 1/2" Model M
30	2,07	925,000	1,300,000	2,105,000	2,900,000
33	2,27	989,000	1,390,000	2,250,000	3,100,000
35	2,41	1,027,000	1,450,000	2,345,000	3,235,000
36	2,48	1,053,000	1,480,000	2,395,000	3,300,000
40	2,76	1,135,000	1,600,000	2,590,000	3,569,000
45	3,10	1,245,000	1,750,000	2,830,000	3,903,000
50	3,45	1,362,000	1,895,000	3,075,000	4,237,000
55	3,79	1,465,000	2,049,000	3,315,000	4,572,000
60	4,13	1,566,000	2,203,000	3,560,000	4,907,000
65	4,58	1,672,000	2,349,000	3,800,000	5,241,000
70	4,82	1,775,000	2,469,000	4,045,000	5,575,000
75	5,17	1,886,000	2,649,000	4,285,000	5,909,000

Series 174A

No.	Size (In)	Model	Height in.	Length in.	Weight lbs.
374A	3/4" x 3/4"	20 x 20	92	2 1/2"	1.13
174A	1" x 1"	25 x 25	130	3"	1.50
174A	1 1/2" x 1 1/2"	32 x 32	146	3 3/8"	2.14
174A	1 1/2" x 1 1/4"	32 x 25	111	3 1/8"	1.44
174A	2" x 2"	50 x 50	229	4 1/2"	7.25
174A	2" x 2"	50 x 50	235	6"	13.75

Series 740

No.	Size (In)	Model	Height in.	Length in.	Weight lbs.
740	3/4" x 1"	20 x 25	143	3"	1.88
740	1" x 1 1/4"	25 x 32	184	3 3/8"	3.13
740	1 1/2" x 2"	32 x 40	222	4 1/8"	6.13
740	1 1/2" x 2"	32 x 40	235	5 1/8"	7.50
740	2" x 2 1/2"	50 x 65	295	6 1/2"	16.50



Water Products Division • Safety & Control Valves

## T991A Proportional Temperature Controllers

### GENERAL

T991A Proportional Temperature Controllers provide modulating control of water or air temperatures in ducts, tanks, and similar applications. Standard models have a sensing bulb and capillary; fast response models have a coiled sensing element that operates at least four times faster than standard controllers, depending upon operating conditions.

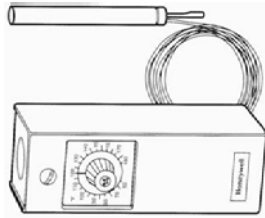

### FEATURES

- All models compensate for effects of ambient temperature on the case and tubing.
- Controls temperature of air or liquid.
- Sensing element capillary tubing allows remote mounting of sensing element.
- Set point may be read and adjusted through cover.
- Throttling dial inside case adjust proportioning range.

### INSTALLATION INSTRUCTION

#### CAUTION

Disconnect power supply.

Installation should be made only by a qualified serviceman. Follow instruction of system manufacturer, if available.

#### LOCATION

The T991A may be mounted in any convenient position on a flat surface where the ambient temperature does not exceed 125°F. When mounting on a hot or cold surface, mount the case on a wood board or other insulating material. The capillary tube provides for remote mounting.

#### MOUNTING

On replacement applications, mount the T991A in place of old control if requirements under LOCATION above, are met. Mount case according to instructions below. Use old sensing bulb hole, bulb holder, immersion well, or compression fitting if these are suitable; otherwise, follow the instructions below for new applications.

#### Mounting the Controller Case

- 1 Remove cover. Using the case as a template, mark three screw hole locations on mounting surface, then punch or drill holes.
- 2 Fasten T991A securely to mounting surface with the furnished mounting screws.

#### To Install Sensing Bulb in Air Duct

Locate the sensing bulb where duct air of average temperature can circulate freely around it. Avoid mounting the bulb close to hot pipes, cooling coils, and other places where air temperatures are not representative.

To support the bulb in the duct, use bulb holder accessory (see Fig. 2).

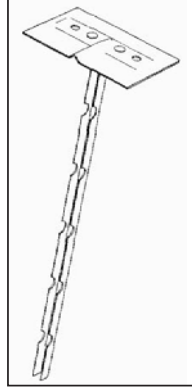

FIG. 2-BULB HOLDER

- 1 Drill a 3/4 inch hole in the duct wall to admit the sensing bulb and holder.
- 2 Using the holder as a template, mark and drill holes for bulb holder mounting screws.

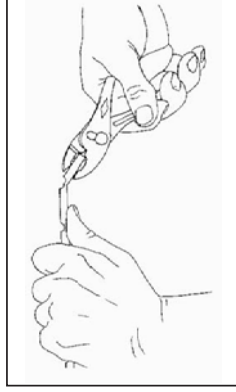

FIG. 3-SHORTENING THE BULB HOLDER.

- 3 Break off bulb holder to desired length, as shown in Fig. 3. NOTE: Holder should be long enough to hold sensing bulb in freely circulating air, away from duct wall. Neatly coil any excess capillary tubing at controller case or at bulb holder.

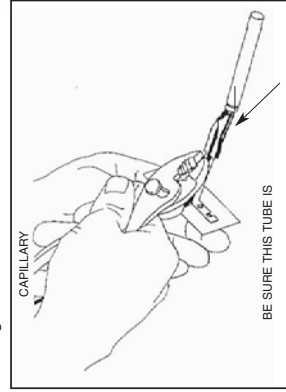

FIG. 4-INSERTING CAPILLARY TUBING IN HOLDER

- 4 Place capillary tubing in bulb holder channel, and pinch top edges of holder together at each segment, as shown in Fig. 4.

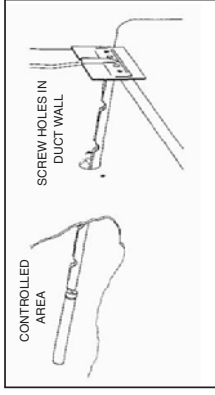

FIG. 5-INSERTION INTO DUCT

- 5 Insert bulb and holder into controlled area through hole prepared in Step 1 (Fig. 5).

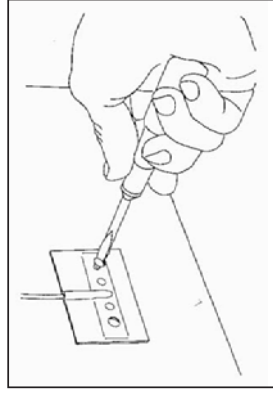

FIG. 6-FASTENING HOLDER TO DUCT WALL.

- 6 Fasten bulb holder to duct wall with screws furnished, as shown in Fig. 6.

#### To Install A Fast Response Model

Use duct holder assembly for the sensing coil. Drill a 1-5/8 inch hole in the duct wall to receive the whole coil, and then use the mounting procedure for the standard model. WARNING: Do not stretch the coil more than eight inches on the holder.

#### To Install Sensing Bulb in Tank Or Boiler

The bulb may be inserted directly into a tank or boiler tapping by means of a pressure fitting, or the bulb may be inserted into an immersion well that is screwed into the tank or boiler.

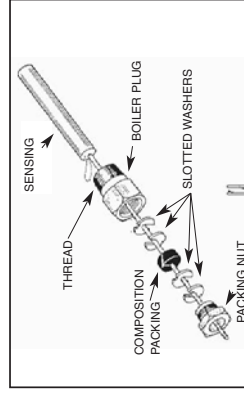
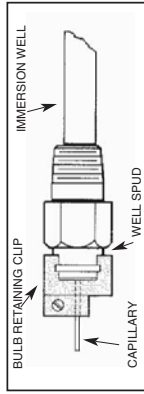

FIG. 7-PRESSURE FITTING ASSEMBLY.



**To install pressure fitting:**

- 1 Drain system, and screw boiler plug into properly sized and threaded boiler or pipe tapping (1/2-14 NPT).
- 2 Place packing nut on T991A capillary tube.
- 3 Slide sensing bulb completely through boiler plug.
- 4 Place composition disc and the four slotted brass washers on tubing in the order shown in Fig. 7.
- 5 Slide the assembly into the boiler plug, and tighten the packing nut.
- 6 Refill the system and check for leaks. Neatly coil excess capillary tubing at T991A case.



**FIG. 8-IMMERSION WELL ASSEMBLY**

**To install immersion well:**

- 1 Drain system. Screw the well into properly sized and threaded boiler tapping or pipe fitting.
- 2 Refill the system and check for leaks.
- 3 Insert sensing bulb into well until it bottoms.
- 4 Fit bulb retaining clamp over immersion well flange and capillary tubing, and tighten screw, as shown in Fig. 8.

Coil excess capillary tubing at T991A case.

**WIRING**

All wiring must comply with local codes.

Two knockouts are provided at top and bottom of case for 1/2 inch conduit. Follow any wiring instructions furnished with heating or cooling system. In replacement applications, make certain the T991A is wired in the system to operate the same way as old control. Fig. 9 shows typical wiring.

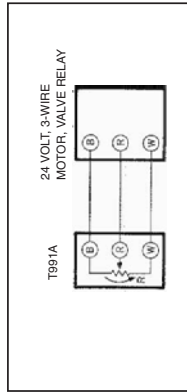

**FIG. 9-TYPICAL HOOKUP**

**ADJUSTMENTS AND CHECKOUT**

**Temperature Setting:** Turn knob on front of case until pointer indicates desired set point temperature. This is the center point of the proportional range.

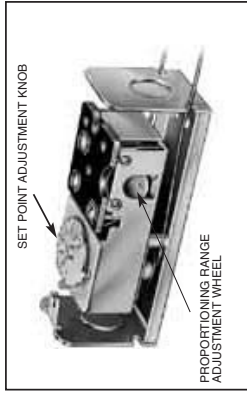

**FIG. 10-PROPORTIONING RANGE ADJUSTMENT**

**Range Adjustment:** The T991A may be adjusted to vary the temperature range within which proportional action is desired. With cover off, turn adjustment wheel until pointer indicates desired range.

**Example:** If the temperature of the controlled medium is to be maintained at 130°F, and proportional action from 125°F to 135°F ( a range of 10 degrees) is desired - turn the temperature set point indicator to 130°F and the proportional range adjustment wheel to 10.

**CHECKOUT**

After mounting and wiring have been completed, let the controlled equipment operate until system temperature stabilizes (from 1 to 3 hours). Observe the motor action to see if it stabilizes. If the motor shaft constantly moves back and forth, widen the T991A proportional range (about five degrees at a time) until the system is stable.

## L4008A,B,E,L; L6008A,G,H Aquastat® Controllers

### INSTALLATION INSTRUCTIONS

L6008G—is used as a 2-stage Aquastat® controller to cycle 2-stage gas valve.  
L6008H—is used as a low fire Aquastat® controller.

If immersion well or capillary compression fitting must be ordered, refer to form 88-0040, Wells and Fittings for Temperature Controllers, for part numbers and ordering information.

### INSTALLATION

#### When Installing this Product...

1. Read these instructions carefully. Failure to follow them could damage the product or cause a hazardous condition.
2. Check the ratings given in the instructions and on the product to make sure the product is suitable for your application.
3. Installer must be a trained, experienced service technician.
4. After installation is complete, check out product operation as provided in these instructions.

#### CAUTION

Disconnect power supply before installation to prevent electrical shock or equipment damage.

Depending on model and installation requirements, install the temperature sensing bulb either in an immersion well (see Fig. 2) that extends into the boiler or tank, or directly immerse the temperature sensing bulb in the liquid. For installations not using a well, secure the bulb with a bulb compression fitting (see Fig. 3), or a capillary compression fitting (see Fig. 4). Order the well or the fitting separately.

The boiler manufacturer generally provides a tapping for inserting the Aquastat® controller sensing element. Locate this tapping in a representative point where typical water temperature can be measured. Never locate the bulb or protecting immersion well close to a hot or cold water inlet or steam coil. Install the bulb in the supply line of an indirect water heater, in the indirect water heater itself, or in the feed riser about 6 in. (152 mm) above the boiler. If the riser is valved, install the bulb between the boiler and the valve.

### APPLICATION

These remote bulb (see Fig. 7), immersion type (see Fig. 1) controllers operate in response to temperature changes in hydronic heating systems and other heated liquids.

#### Electrical Ratings:

Switch ratings are shown on the inside cover of each device. The electrical requirements on controlled equipment must not exceed this rating.

L4008A—breaks the burner circuit on a rise in water temperature. It is normally used as a limit controller. When used as an operating controller or low limit, a separate high limit control must be used.

L4008B—makes a control circuit on a rise in water temperature. It is normally used as a circulator controller to prevent circulator operation until boiler water temperature is at or above the control setting.

L4008E—breaks the burner circuit and locks out on a rise in water temperature. It is used as a high limit controller where manual reset is desirable.

L4008L—is used as a 2-stage Aquastat® controller. L6008A—makes the burner circuit on a drop in water temperature. It is normally used as a circulator and low limit cooling controller.

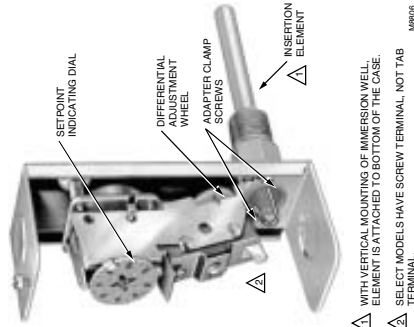

Fig. 1. Internal view.

- △ WITH VERTICAL MOUNTING OF IMMERSION WELL, ELEMENT IS ATTACHED TO BOTTOM OF THE CASE.
- △ SELECT MODELS HAVE SCREW TERMINAL, NOT TAB TERMINAL.

The Aquastat® controller can be remotely mounted—either vertically on a wall or panel, or directly on the boiler, tank, or vessel.

If the system is filled, drain the system to a point below the boiler tapping, or to wherever the sensing bulb is to be installed.

#### Mounting the Case

1. Remove the cover and fasten the case to the wall or panel using the three mounting holes in the back of the case.
2. When mounting the remote bulb, if desirable, route the tubing to run through any of the other three corner notches in the case. Be careful not to kink or bend tubing sharply. Be sure bends have at least 1 in. (25.4 mm) radius.

#### Installing Remote Bulb with Immersion Well

Fit well, if used, to sensing bulb snugly for good thermal response. Insert bulb until it rests against the bottom of the well; then hold it there while tightening the tubing clamp.

1. Screw the well into the boiler, tank or pipe tapping.
2. Insert the bulb into the well, pushing the tubing until the bulb bottoms in the well.
3. Attach the retainer clamp to the end of the well spud. Loosen the draw nut and spread the jaws of the clamp with the screwdriver if necessary.
4. With the retainer clamp attached to the well spud (be sure jaws of clamp hook over ridge at end of the spud, as shown in Fig. 2, points A), adjust tubing to fit through retainer clamp groove, as shown at point B. Tighten the draw nut so the retainer clamp is firmly attached to the well spud and the tubing is held by the clamp.

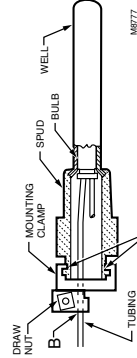
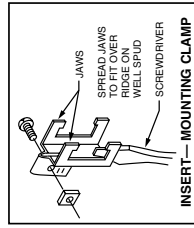

Fig. 2. Immersion well fitting.

**IMPORTANT**  
Do not secure draw nut so tightly that retainer clamp could cut or collapse tubing.

#### Mounting with Bulb Compression Fitting

1. Screw the fitting into the boiler or pipe tapping.
2. Slide sealing washer onto the bulb.
3. Insert the bulb into the fitting until bulb bottoms.
4. Slide split sleeve into fitting.
5. Place clamps A and B on assembly so that sleeve is drawn into fitting when screws are tightened.

**NOTE:** Make sure that the nub on clamp A engages space between sleeve and clamp.

6. Tighten clamp screws evenly.

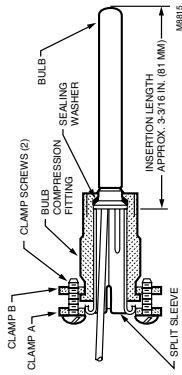

Fig. 3. Bulb compression fitting.

#### Mounting with Capillary Compression Fitting

1. Screw fitting into the boiler or pipe tapping.
2. Place packing nut on tubing.
3. Slide bulb completely through fitting.
4. Place composition disc and 4 slotted brass washers on tubing in the order shown in Fig. 4. Turn brass washers so that slots are 180 degrees to each other.
5. Slide seal assembly into fitting and tighten packing nut.

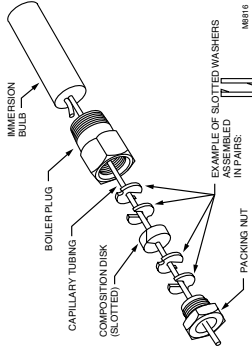

Fig. 4. Capillary compression fitting.

### WIRING

All wiring must agree with applicable codes and ordinances and regulations in such matters as wire size, type of insulation, and enclosure. The controllers are provided with conduit knockouts in the top and bottom of case.

Refer to Fig. 5 or 6 for a typical connection diagram.



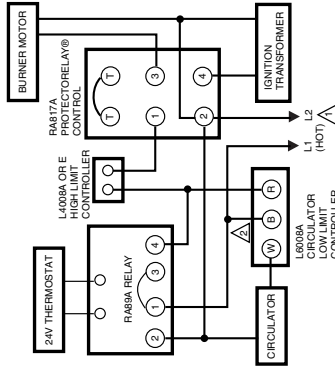

△ POWER SUPPLY PROVIDE DISCONNECT MEANS AND OVERLOAD PROTECTION AS REQUIRED.  
 △ SELECT MODELS HAVE 1/4 IN. TAB TERMINAL FOR W TERMINAL.  
 M878

Fig. 5. Typical oil-fired hydronic heating system with domestic hot water.

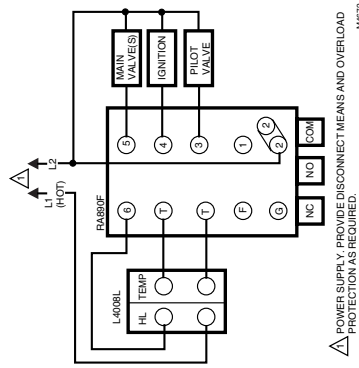

△ POWER SUPPLY PROVIDE DISCONNECT MEANS AND OVERLOAD PROTECTION AS REQUIRED.  
 M872

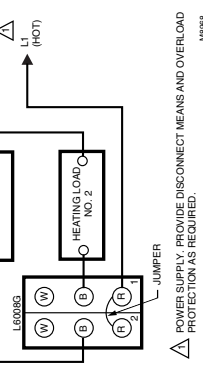

△ SELECT MODELS HAVE A SCREW TERMINAL INSTEAD OF TAB TERMINAL.  
 M889

Fig. 7. Adjusting the differential.

## SETTING

**Control Point:** Insert a screwdriver in the slotted head visible through the cover, and turn the indicating dial to the control point. Temperature settings should be according to boiler manufacturer's recommendations.

**Differential (on adjustable differential models):** Remove cover and move the differential adjustment wheel (Fig. 1 or 7) to a point on the scale corresponding to the desired differential. Replace cover.

**Manual Reset (L4008E):** After boiler water temperature has dropped to a point below the high limit setting, the reset button at the front of the case must be pushed before the burner can operate.

## ADJUSTMENTS

**Adjusting Differential**  
 Set the differential to correspond with the boiler manufacturer recommendations. To adjust models with adjustable differential, rotate the wheel on the back of the snap switch, see Fig. 7, until the desired reading is aligned with the V notch in the frame. The wheel provides as adjustment from 5° to 30°F (3° to 17°C). Replace the cover on the Aquastat® controller.

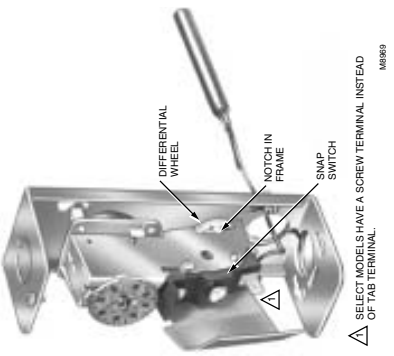

△ SELECT MODELS HAVE FOUR TERMINALS.  
 M892

Fig. 8. Interstage differential adjustment on an L4008L or L6008G.

## CHECKOUT

**Adjusting L6008G Interstage Differential**  
 The L6008G Controller has an adjustable interstage differential. The setpoint adjustment knob determines the temperature at which the right switch operates. The left switch can be adjusted to operate from 3° to 10°F (1.7° to 5.6°C) above the point of operation of the right switch. The interstage differential is adjusted by turning the star wheel with a narrow screwdriver inserted into the rectangular hole in the chassis. See Fig. 8

**WARNING**  
**CAN CAUSE PROPERTY DAMAGE, SEVERE INJURY OR DEATH.**  
 This product is intended for use only in systems with a pressure relief valve.

Check to be sure the Aquastat® controller is properly installed and adjusted. Put the system into operation and observe the action of the control through several cycles to make sure that it provides proper control of the system as described in the Operation section. Make any additional adjustments necessary to assure comfort requirements.

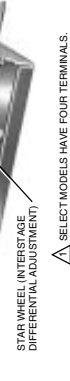

△ SELECT MODELS HAVE FOUR TERMINALS.  
 M892

Fig. 8. Interstage differential adjustment on an L4008L or L6008G.

## Honeywell

Helping You Control Your World



**Home and Building Control**  
 Honeywell Inc.  
 1985 Douglas Drive North  
 Golden Valley, MN 55422

**Home and Building Control**  
 Honeywell Limited-Hongywell Limitée  
 740 Ellesmere Road  
 Scarborough, Ontario  
 M1P 2Y9

## Series 26/26H – Low Water Cutoff

- ▶ Meets CSD1 Requirements
- ▶ Snap-Thru Standoff Mounting
- ▶ Non Powered Contacts
- ▶ Compact Size
- ▶ Power Outage Feature
- ▶ Time Delays Available
- ▶ LED Monitoring
- ▶ CSA Approved
- ▶ U.L. "Limit Control"

Designed for boiler low-water cutoff protection. A snap-through standoff mounting device is available for Series 26 units. Optional Power Outage feature resets after nuisance outages. Optional reset button is used when device has been deactivated because of low water condition. Reset is functional only if water has returned to normal level. Built-in 3 second time delay, 6 second delay available.

### Specifications

<b>Contact Design</b>	1 N.O. & 1 N.C. (1 form C)
<b>Contact Rating (120, 240 VAC)</b>	10 amp Resistive 1/3 hp
<b>Mode of Operation</b>	Direct
<b>Sensitivity</b>	0-26K ohm, factory set
<b>Primary Voltage</b>	120 VAC, 240 VAC*, 24 VAC, 208/240 VAC (+10%/-15%) 50/60 Hz
<b>Secondary Voltage</b>	12 VAC, 1.5 mA
<b>Approvals</b>	UL 353, UL 508 File # MP1430, CSA
<b>Terminal Strip</b>	Spade connection
<b>Options</b>	Time Delays, Power Outage, Retrofit Plate

Notes:  
1. For applications requiring higher contact ratings, request information on 26P (16 amp contact rated).  
2. 240 volt is not U.L.

### How to Order

Use the **Bold** characters from the chart below to construct a product code.

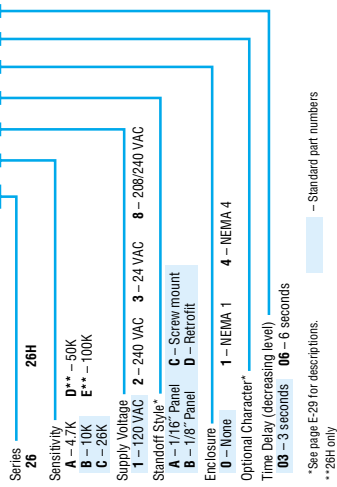

## Warrick® Series 26 Controls Installation and Operation Bulletin

This bulletin should be used by experienced personnel as a guide to the installation of Series 26 controls. Selection or installation of equipment should always be accompanied by competent technical assistance. We encourage you to contact Gems Sensors Inc., or its local representative if further information is required.

### Specifications

**Control Design:** Open circuit board design  
**Contact Design:** SPDT (1 form C); one normally open (N.O.) and one normally closed (N.C.), non-powered contacts.  
**Contact Ratings:** 10A @ 120 or 240 VAC resistive (120°F), 1 A @ 120, 240 VAC resistive (150°F), 1/3 H.P. @ 120, 240 VAC (120°F)  
**Contact Life:** Mechanical: 5 million operations. Electrical: 100,000 operations minimum at rated load.  
**Supply Voltage:** 120, 240 or 24 VAC models: +10% - 15%, 50/60 Hz. 208/240 Model: 187 Vmin to 255 Vmax. VAC 50/60 Hz  
**Supply Current:** Relay energized 4.4 VA. 1.5 milli-amp current.  
**Secondary Circuit:** 12 VAC RMS voltage on probes, 1.5 millivolt current.  
**Sensitivity:** Models operate from 4.7K to 26K maximum specific resistance  
**Temperatures:** -40 to 150° F. ambient.  
**Terminals:** Probe connections 3/16" spade; Line and power connections 1/4" space  
**Time Delays:** Standard - L.L.C.O probe, 3 seconds on lowering level  
**Listing:** UL limit control recognition (353). 240 and 208/240 volt units are not U.L. limit control recognized.

### Installation

1. Drill three .187 dia. holes in customer supplied backplate using stick on template supplied with control. Standard standoffs are designed for backplate thickness of .062 (1/16"), Standoffs are available for backplates of .125 (1/8") nominal thickness. If retrofit plate standoffs are used, drill three .250 dia. holes in proper location.
  2. Install three standoffs onto backplate. Install circuit board onto standoffs by pushing down on circuit board at outer edges of all four corners. Use both hands to slide board onto standoffs until standoffs lock.
- CAUTION:** Do not overflex circuit board during installation. Do not push down on transformer or relay during installation. See sketch for proper installation. Install control in appropriate enclosure.
3. Wire control per diagram, following N.E.C. and local codes. Use appropriately sized spade terminals.

### Standoffs

We have four different types of standoffs, designed to connect circuit boards to panels

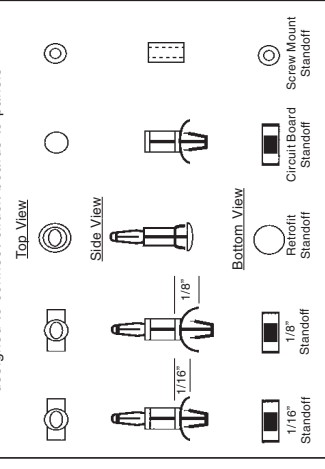

### Sensitivities vs Maximum Probe Wire Distance\*

SENSITIVITY CHARACTER	SENSITIVITY (KOHMS)	DISTANCE (FT)
A	4.7	900
B	10	600
C	26	250

\* Based on type MTW or THHN wire, # 14 or # 16 AWG

### Dimensions

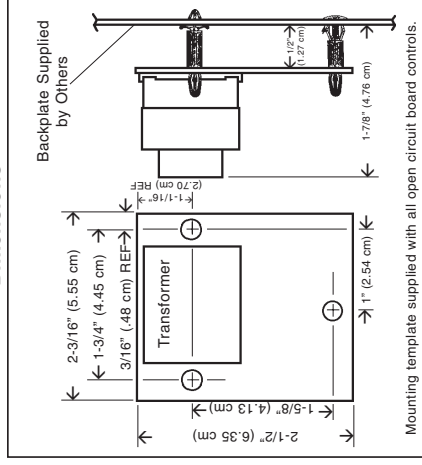

### Notes

- If panel mount stand-off is to be used, thru-holes to be drilled in back plate should be .187" Dia.
- If retrofit stand-off is to be used, thru-holes to be drilled in back plate should be .250" Dia.

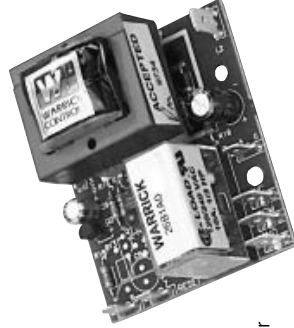

### Applications

- Low-Water Cutoff
- Point Level
- Valve Control
- Single-Level Service
- Alarms
- Pump Control

### Dimensions

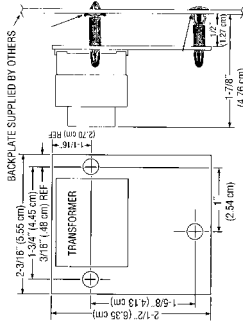

### Wiring

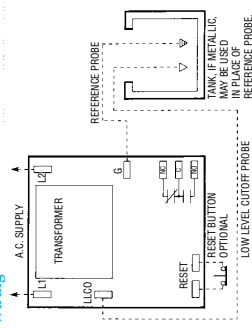

### Wiring Diagram

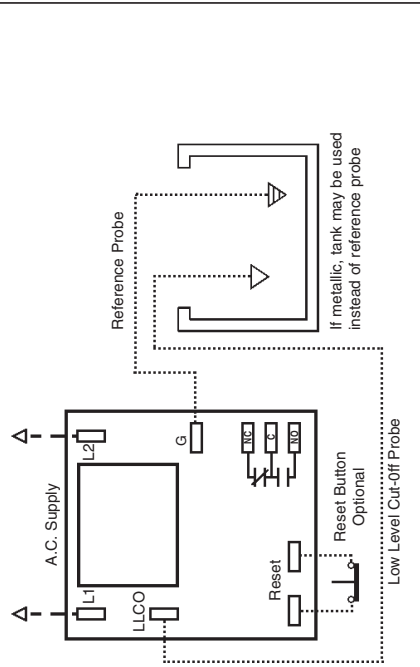

**AUTOMATIC RESET** (Reset terminals not used) When the liquid rises to the electrode on terminal LLCO, the control energizes, changing state of the load contacts. (LED will be lit) The control remains energized until the liquid level recedes below electrode on terminal LLCO. The control then de-energizes. (LED will not be lit) returning load contacts to original state. Unless otherwise specified, there is a three second time delay on decreasing level. Liquid must be below probe on terminal LLCO for a full three seconds before control de-energizes.

**MANUAL RESET** (Normally closed pushbutton installed across reset terminals) When the liquid rises to the electrode on terminal LLCO, the control will remain de-energized until the pushbutton is depressed. The control will then energize. (LED will be lit) changing the state of the contacts. The control remains energized until the liquid level recedes below electrode on terminal LLCO. The control then de-energizes. (LED will not be lit) returning load contacts to their original state. Unless otherwise specified, there is a three second time delay on decreasing level. Liquid must be below probe on terminal LLCO for full three seconds before control de-energizes.

**MANUAL RESET OPTIONAL POWER OUTAGE FEATURE** (Normally closed pushbutton across reset terminals) Control will ignore power loss to control. With liquid above electrode on terminal LLCO, a power outage will cause the control to de-energize, but will automatically energize upon return of power. However, loss of liquid will cause control to de-energize and remain so until liquid again rises to electrode and pushbutton is depressed.

## Series DF – Dual Function Controls

- ▶ Solid State Reliability
- ▶ Compact Size
- ▶ Meets CSD1 Requirements
- ▶ CSA Approved
- ▶ U.L. "Limit Control"
- ▶ Spade Terminals for Easy Wiring
- ▶ Manual Reset (optional)
- ▶ Power Outage Feature (optional)
- ▶ U.L. "Motor Control"

Dual function Series DF models are designed to control two independent level functions, one single-level control operation and one differential-level operation.

Optional Power Outage feature resets after nuisance outages. Optional Reset Button is used when device has been deactivated due to low water condition. Reset is activated only after water has returned to normal level. This control is ideal in applications on boilers, food service equipment, and chemical delivery systems.

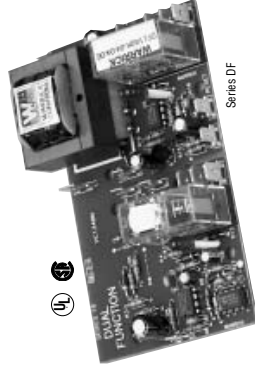

### Applications

- Dual Function
- Single-Level Service
- Differential Service
- Feedwater Control / Low-Water Cutoff
- High Level / Low Level
- Pump Down / High Level

### Dimensions

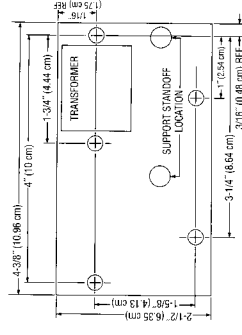

### Wiring

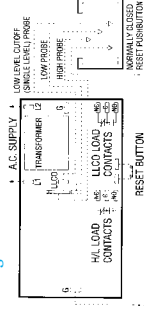

Note: For single level service, use "H" and "G" connections.

### Specifications

<b>Contact Design</b>	1 N.O. & 1 N.C. (1 form C) extra function
<b>Contact Rating (120-240 VAC)</b>	10 amp Resistive 1/3 hp
<b>Mode of Operation</b>	H/L Direct/Inverse, LLCO – factory set
<b>Sensitivity</b>	0-26K ohm, factory set
<b>Primary Voltage</b>	120 VAC, 240 VAC, 24 VAC (+10%/-15%), 50/60 Hz
<b>Secondary Voltage</b>	12 VAC
<b>Temperature</b>	-40°F to 150°F
<b>Approvals</b>	U.L. 508 File # MP1430, U.L. 353 File # E44426, CSA
<b>Terminal Style</b>	Spade connection
<b>Options</b>	Time Delays, Manual Reset, Power Outage, Retrofit Plate

Note: 1. 240 VAC unit does not carry U.L. Limit Control recognition.

### How to Order

Use the **Bold** characters from the chart below to construct a product code.

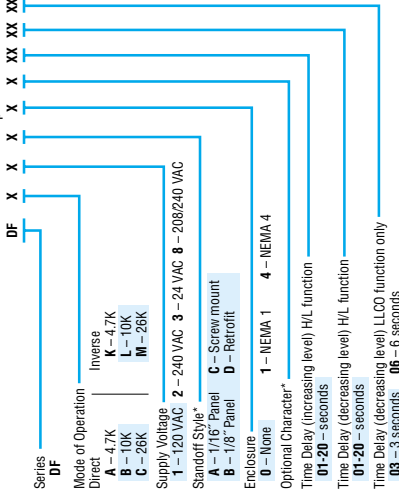

\*See page E-29 for descriptions. — Standard part numbers

## CONDUCTIVITY

### Optional Character Chart

	N.C. Pushbutton	Power Outage	Retrofit Plate
C	X		
E		X	
F	X		
N		X	X
P	X	X	X
R			X

Gems Sensors Inc.  
One Cowles Road  
Plainville, CT 06062-1198  
Tel: 860-793-4579  
Fax: 860-793-4580





## Warrick® Dual Function Controls Installation and Operation Bulletin



This bulletin should be used by experienced personnel as a guide to the installation of Dual Function Controls. Selection or installation of equipment should always be accompanied by competent technical assistance. We encourage you to contact Gems Sensors or its representative if further information is required.

### Specifications

**Control Design:** Open circuit board design  
**Contact Design:** SPDT (1 form C); one normally open (N.O.) and one normally closed (N.C.); non powered contacts for limit control and SPDT (1 form C); one normally open (N.O.) and one normally closed (N.C.); non powered contacts for level control

**Contact Ratings:** 10A @ 120, 208/240, 240 VAC resistive (120°F), 1A @ 120, 208/240, 240 resistive (150°F), 1/3 Hp @ 120, 208/240, 240 VAC  
**Contact Life:** Mechanical - 5 million operations Electrical - 100,000 operations minimum at rated load

**Supply Voltage:** 120, 240, or 24 VAC models, +10%, -15%, 50/60 Hz. 208/240 Model: 187V Min to 255V Max, VAC 50/60 Hz  
**Power Consumption:** 120, 208/240, 240, or 24 VAC both relays energized - 4 VA.  
**Secondary Circuit:** 12 VAC RMS voltage on probes; 1.5 milli-amp current.

**Sensitivity:** Models operate from 0-26K ohms maximum specific resistance (factory set)  
**Temperature:** -40° to 150° F ambient  
**Terminals:** Probe connections 3/16" male quick connects, Line and Power connections 1/4" male quick connects

**Time Delays:** Standard, 0.5 seconds rising level, LLCO probe, 3 seconds lowering level.  
**Listings:** Entire control carries U.L., motor controller recognition (UL 508) and U.L. Limit controller recognition (UL 353). 208/240 and 240 VAC models carry only motor controller recognition (UL 508)

**Installation**  
 1. Drill five .187 holes in customer supplied back plate using stick on template supplied with control. Standard standoffs are designed for back plate thickness of 0.062 (1/16"). Standoffs are available for back plates of 0.125 (1/8") nominal thickness. If retrofit plate standoffs are used, drill 5 (five) 0.250 dia. Holes in proper locations. Install five standoffs into back plate. Install two support standoffs into circuit board. Snap circuit board onto standoffs. See sketch for proper installation. Install control in an appropriate enclosure.

2. Wire control per wiring diagram, following N.E.C. and local codes. Use appropriately sized spade terminals.

### Standoffs

We have four different types of standoffs designed to connect circuit boards to panels

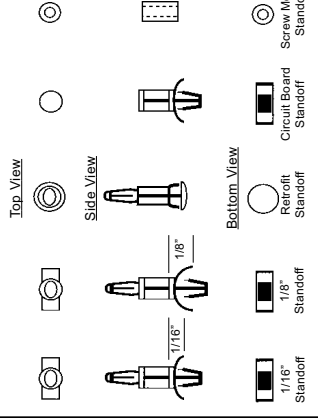

### Dimensional Drawing

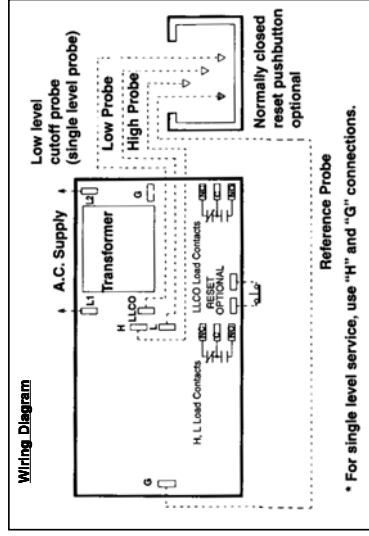
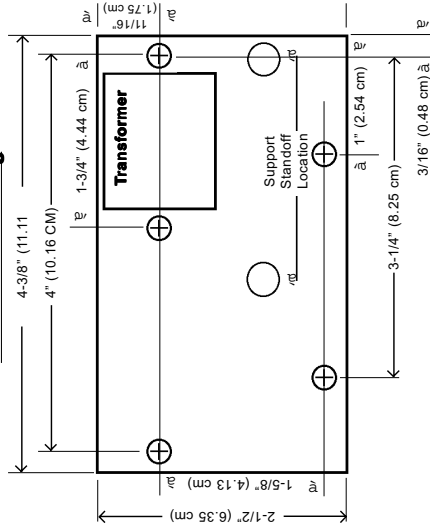

\* For single level service, use "H" and "G" connections.

### Operation

#### DIRECT MODE BOTH FUNCTIONS

**LLCO Function:** When the liquid rises to the electrode on terminal LLCO, the relay associated with terminal LLCO energizes, changing state of the load contacts. (LED will be lit). The relay remains energized until the liquid level recedes below electrode on terminal LLCO. The associated relay then de-energizes. (LED will not be lit) returning load contacts to original state. Unless otherwise specified, there is a three-second time delay on decreasing level. Liquid must be below probe on terminal LLCO for full three seconds before control de-energizes.

**H, L Function:** When the liquid rises to the electrode on terminal H, the associated relay energizes, changing the state of the load contacts. (LED will be lit). The relay remains energized until the liquid level recedes below electrode on terminal L. The associated relay then de-energizes. (LED will not be lit) returning load contacts to original state. Unless otherwise specified, there is a one half second time delay on increasing level. Liquid must be in contact with probe on terminal H for a full half second before control energizes. This function can be wired for single level service by using only the H terminal.

#### INVERSE MODE

**LLCO Function:** LLCO always functions in direct mode only see above for operation.  
**H, L Function:** Associated relay energizes with power, (LED will be lit) changing the

state of the load contacts. When the liquid rises to the electrode on terminal H, the relay de-energizes, returning load contacts to shelf state. (LED will not be lit). The associated relay remains de-energized until the liquid level recedes below electrode on terminal L. The relay then energizes.

### Optional

**Optional Manual Reset:** (Normally closed pushbutton across reset terminals. Pushbutton ordered separately). Manual reset only applies to the function associated with terminal LLCO. When the liquid rises to the electrode on terminal LLCO, the control will remain de-energized (load contacts in original state) until the pushbutton is depressed. The control will then energize. (LED will be lit) changing the state of the contacts. The control remains energized until the liquid level recedes below electrode on terminal LLCO. The control then de-energizes. (LED will go off) returning load contacts to their original state. Unless otherwise specified, there is a three second time delay on decreasing level. Liquid must be below probe on terminal LLCO for full three seconds before control de-energizes.

**Manual Reset with optional Power Outage Feature:** Reset (Normally closed pushbutton across reset terminals. Pushbutton ordered separately) Control will ignore power loss to control. With liquid in contact with electrode on terminal LLCO, a power outage of less than 250 m sec. Will cause the control to de-energize, but will automatically energize upon return of power. However, loss of liquid will cause control to de-energize and remain so until liquid again rises to electrode and de-energizes.

**Time Delays associated with terminals H and L:** With time delay on increasing level, the liquid must be in contact with the high electrode for the full duration of the time delay before the control will operate. With delay on decreasing level, the liquid must be below the low electrode for the full duration of the time delay before control will operate. In single level service, terminals 3 and 4 must be jumpered together to achieve time delays on both increasing and decreasing levels or just decreasing level.

**Time Delays associated with terminal LLCO:** 3 Second time delay on decreasing level is standard. A 6 second time delay can be specified and would act in the same manner as listed above.

### Optional Character Chart

	Reset Function	N.C. Pushbutton	Power Retrofit Outage
D	x		
G	x	x	x
J	x	x	x
K	x		x
L	x		x
R		x	x
S	x	x	
T	x	x	x
W	x		x

Gems Sensors Inc.  
 One Cowles Road  
 Plainville, CT 06062-1198  
 Tel: 860-793-4579  
 Fax: 860-793-4580



## Series 3E – Pipe Thread Attachment Series 3N – Flat Surface Mounting

- ▶ Up to 7 Probes
  - ▶ Flat Mounting (3N)
- ▶ Threaded Attachment (3E)
  - ▶ Available in Various Body Metals
  - ▶ U.L. Recognized (3E)
- ▶ CSA Approved
- ▶ FM Approved (3E)

Series 3E fittings are cast metal, pressure-tight assemblies capable of handling 1-7 probes. Attachment to vessels is accomplished with external pipe threading. 3E fittings require the use of 3R rigid or 3W wire suspended electrodes.

Series 3N fittings accommodate 1-3 probes operating at atmospheric pressure. The assembly mounts on a flat surface atop open tanks or closed vessels. 3N fittings require the use of 3R rigid or 3W wire suspended electrodes.

### Specifications

<b>Type of Connection</b>	Threaded
<b>Series 3E</b>	Bracket
<b>Series 3N</b>	Bracket
<b>Probes</b>	
<b>Series 3E</b>	1 thru 7
<b>Series 3N</b>	1 thru 3
<b>Terminal Housing</b>	Die cast aluminum, epoxy coated
<b>Body Material</b>	
<b>Series 3E</b>	Cast iron, red brass, 316 stainless steel
<b>Series 3N</b>	PVC, red brass, 316 stainless steel
<b>Pressure/Temperature</b>	
<b>Series 3E</b>	125 psig @ 353°F (cast iron); 250 psig @ 406°F (brass, 316 s.s.)
<b>Series 3N</b>	0 psig @ 150°F (PVC); 0 psig @ 500°F (brass, 316 s.s.)
<b>Approvals</b>	
<b>Series 3E</b>	U.L. File # MP2489, Vol. 1, Sec. 2, CSA; FM
<b>Series 3N</b>	CSA File # LR11644

### Dimensions

Series	No. of Probes	Attachment to Vessel	Conduit Boss Thread Size	Terminal Housing Size (W x D x H)
3E	1	1" NPT	1/2" NPT	2-1/4 x 2-1/4 x 2-1/4
	2	2" NPT	1/2" NPT	3-1/4 x 3-1/4 x 2-3/8
	3	2" NPT	1/2" NPT	3-1/4 x 3-1/4 x 2-3/8
	4	2-1/2" NPT	1/2" NPT	3-1/4 x 3-1/4 x 2-3/8
	5	3" NPT	3/4" NPT	4 x 4 x 2-1/2
	6	3" NPT	3/4" NPT	4 x 4 x 2-1/2
3N	7	3" NPT	3/4" NPT	4 x 4 x 2-1/2
	1	2-1/4" square flat pad, 1-1/2" dia. hole in top of vessel secured	1/2" NPT	2-1/4 x 2-1/4 x 2-1/4
	2	with #10 machine screws at the corners of a 1-1/2" square	1/2" NPT	3-1/4 x 3-1/4 x 2-3/8
3		1/2" NPT	3-1/4 x 3-1/4 x 2-3/8	



### Applications

- Open Tanks
- Closed Vessels
- Water
- Diluted Corrosive Liquids

### How to Order

Use the **Bold** characters from the chart below to construct a product code.

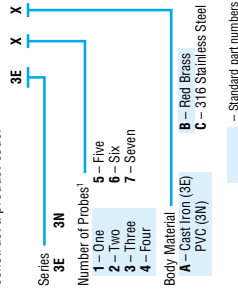

Note:  
1. 3N features up to three probes only.



Installation & Maintenance  
Instructions MM-217(E)

McDonnell & Miller



ITT Industries



**Series 150 and 157**  
(Mercury Switch)

**Series 150S and 157S**  
(Snap Switch, All Models except 157S-RB-P)

**Low Water Cut-Off/Pump Controllers**  
For Steam Boilers and Other Level Control Applications

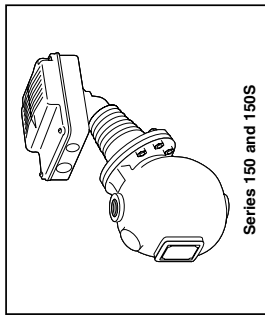

Series 150 and 150S

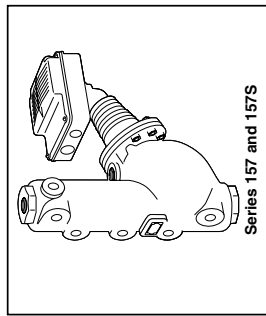

Series 157 and 157S

**Typical Applications:**

- Primary or secondary pump controller/ low water fuel cut-off for steam boilers
- Motorized valve controller
- Low water cut-off
- High water cut-off
- Alarm actuator

**WARNING**

- Before using this product read and understand instructions.
  - Save these instructions for future reference
  - All work must be performed by qualified personnel trained in the proper application, installation, and maintenance of plumbing, steam, and electrical equipment and/or systems in accordance with all applicable codes and ordinances.
  - To prevent serious burns, the boiler must be cooled to 80° F (27° C) and the pressure must be 0 psi (0 bar) before servicing.
  - To prevent electrical shock, turn off the electrical power before making electrical connections.
  - This low water cut-off must be installed in series with all other limit and operating controls installed on the boiler. After installation, check for proper operation of all of the limit and operating controls, before leaving the site.
  - To prevent serious personal injury from steam blow down, connect a drain pipe to the control opening to avoid exposure to steam discharge.
  - To prevent a fire, do not use this low water cut-off to switch currents over 7.4A, 1/3 Hp at 120 VAC or 3.7A, 1/3 Hp at 240 VAC, unless a starter or relay is used in conjunction with it.
- Failure to follow this warning could cause property damage, personal injury or death.

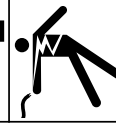

**OPERATION**

Maximum Pressure: 150 psi (10.5 kg/cm<sup>2</sup>)

**Electrical Ratings**

Voltage	Pump or Motorized Valve Circuit Rating (Amperes)		Pilot Duty
	Full Load	Locked Rotor	
120 VAC	7.4	44.4	345 VA at 120 or 240 VAC
240 VAC	3.7	22.2	

Alarm Circuit Rating Voltage	Amperes
120 VAC	1
240 VAC	1/2

Motor Horsepower	Voltage	Hp
120 VAC	1	1/3
240 VAC	1/2	1/3

**Settings and Differential Pressures**

Values are ± 1/8" (3.2mm).

**Series 150/157 and 150S/157S**

Pressure	Setting	Approximate Distance Above Cast Line In. (mm)	Differential In. (mm)
0 psi (0 kg/cm <sup>2</sup> )	Pump Off	15/16 (24)	5/16 (8)
	Pump On	5/8 (16)	
	Burner On	5/8 (16)	3/8 (16)
150 psi (10.5 kg/cm <sup>2</sup> )	Pump Off	1 3/8 (41)	3/4 (19)
	Pump On	5/8 (16)	
	Burner On	7/8 (22)	7/8 (22)
	Burner Off	0 (0)	

**150 psi (10.5 kg/cm<sup>2</sup>) Levels**

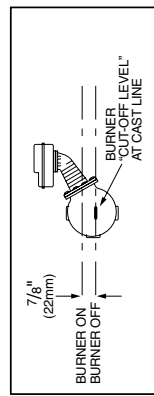
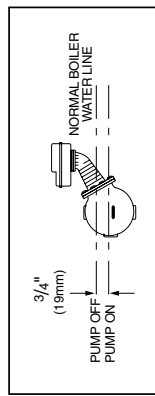
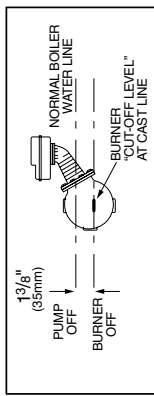

**Models 150-MD/157-MD and 150S-MD/157S-MD**

Pressure	Setting	Approximate Distance Above Cast Line In. (mm)	Differential In. (mm)
0 psi (0 kg/cm <sup>2</sup> )	Pump Off	15/16 (24)	3/8 (16)
	Pump On	9/16 (14)	
	Burner Off	0 (0)	N/A
150 psi (10.5 kg/cm <sup>2</sup> )	Pump Off	1 7/16 (37)	3/4 (19)
	Pump On	1 1/16 (17)	
	Burner Off	- 3/8 (-16)	N/A

**150 psi (10.5 kg/cm<sup>2</sup>) Levels**

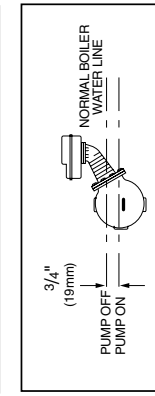
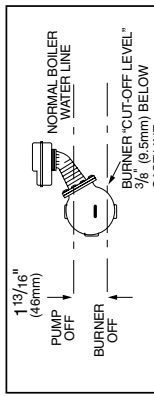

### Settings and Differential Pressures (continued)

Values are  $\pm 1/8"$  (3.2mm).

Models 158 and 158S		Approximate Distance Above Cast Line (mm)	Differential In. (mm)
Pressure	Motorized	15/16 (24)	5/16 (8)
	Valve Closed	5/8 (16)	
0 psi (0 kg/cm <sup>2</sup> )	Motorized	5/8 (16)	3/8 (16)
	Valve Open	1/4 (6.4)	
150 psi (10.5 kg/cm <sup>2</sup> )	Burner On	13/8 (41)	3/4 (19)
	Burner Off	5/8 (16)	
150 psi (10.5 kg/cm <sup>2</sup> )	Motorized	5/8 (16)	7/8 (22)
	Valve Open	0 (0)	
		7/8 (22)	
		0 (0)	

#### 150 psi (10.5 kg/cm<sup>2</sup>) Levels

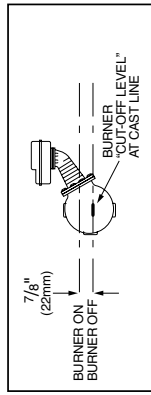
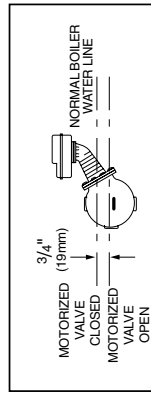
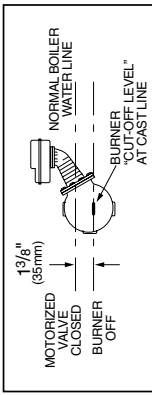

**Note:** Due to the slower operation of some motorized valves, complete valve opening or closing will occur at slightly different levels than indicated above.

#### Models 159 and 159S

Pressure	Setting	Approximate Distance Above Cast Line (mm)	Differential In. (mm)
0 psi (0 kg/cm <sup>2</sup> )	Pump #1 Off	15/16 (24)	5/16 (8)
	Pump #1 On	5/8 (16)	
	Pump #2 Off	5/8 (16)	
	Pump #2 On	1/4 (6.4)	
150 psi (10.5 kg/cm <sup>2</sup> )	Pump #1 Off	13/8 (41)	3/4 (19)
	Pump #1 On	5/8 (16)	
	Pump #2 Off	7/8 (22)	
	Pump #2 On	0 (0)	

#### 150 psi (10.5 kg/cm<sup>2</sup>) Levels

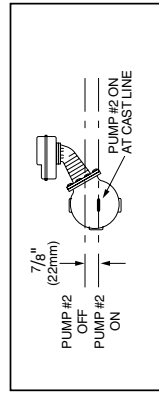
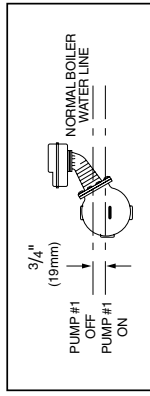
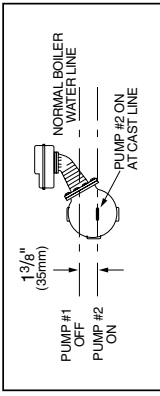

## INSTALLATION –

### TOOLS NEEDED:

Two (2) pipe wrenches, one (1) flathead screw driver, and pipe sealing compound.

**IMPORTANT:** Follow the boiler manufacturer's instructions along with all applicable codes and ordinances for piping, blow down valve and water gauge glass requirements.

### STEP 1 - Determine the Elevation at Which the Low Water Cut-Off/Pump Controller Must be Installed

If the control will be the primary low water fuel cut-off, size the steam (top) and water (bottom) equalizing pipe lengths so that the horizontal cast line on the body is 1 3/8" (35mm) below the boiler's normal water level, but not lower than the lowest, safe permissible water level, as determined by the boiler manufacturer.

OR

If the control will be the secondary low water fuel cut-off, size the steam (top) and water (bottom) equalizing pipe lengths so that the horizontal cast line on the body is at or above, the lowest, safe permissible water level, as determined by the boiler manufacturer.

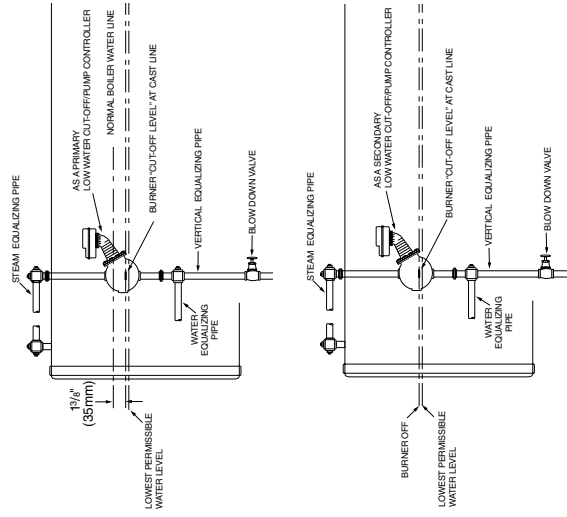

### STEP 2 - Installing the Low Water Cut-Off

- Using a pipe wrench, unscrew the plastic float blocking plug (A) from the low water cut-off body (B).

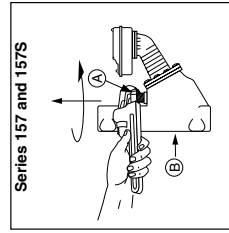
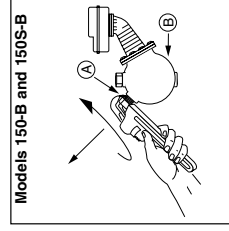
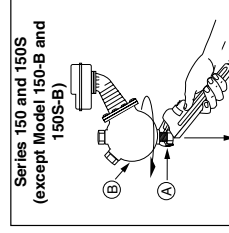

**b. For Models 150-B and 150S-B and Series 157 and 157S** (For all other models, proceed to Step 3).

Screw the 3/4" NPT steel plug (C) (provided) in tapping (A).

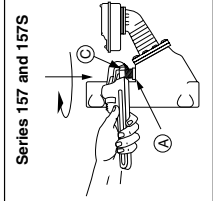
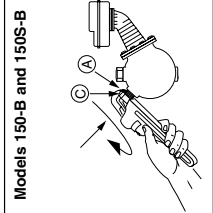

**c. Mount and pipe the low water cut-off (D) on a vertical equalizing pipe (E) at the required elevation level, as determined in Step 1.**

Install a full ported blow down valve (G) directly below the lower cross of the water equalizing pipe (F).

**Note:** 1" NPT tappings are provided, with the exception of some 157 and 157S models which are 1/4" NPT.

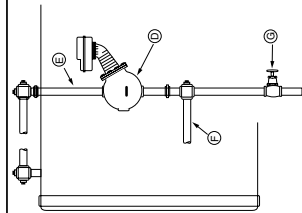

**STEP 3 - Installing a Water Gauge Glass (Required on all steam boilers)**

**a. Install a water column (H) (not included with product) for all models except Series 157 and 157S (with integral water column).**

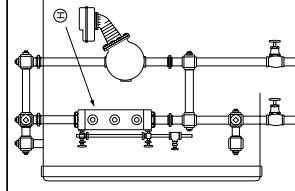

**b. Install a water gauge glass (J).**  
**Note:** Gauge glass and tri-cocks not included with product.

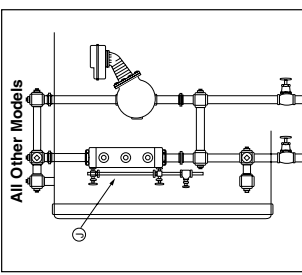
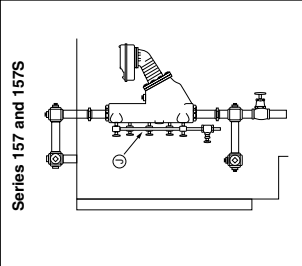

**STEP 4 - Electrical Wiring**

**WARNING**

- To prevent electrical shock, turn off the electrical power before making electrical connections.
  - This low water cut-off must be installed in series with all other limit and operating controls installed on the boiler. After installation, check for proper operation of all of the limit and operating controls, before leaving the site.
  - Modification of the switch assembly before or after installation could cause damage to the boiler and/or boiler system.
- Failure to follow this warning could cause electrical shock, an explosion and/or a fire, which could result in property damage, personal injury or death.



**Switch Operation**

**For all Models except 158/158S and 159/159S**

Boiler feed pump off, burner on, alarm off.

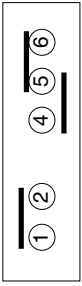

Boiler feed pump on, burner on, alarm off.

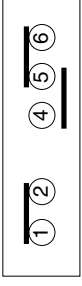

Boiler feed pump on, burner off, alarm on.

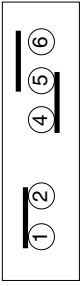

**For Models 158 and 158S**

Motorized valve closed, burner on, alarm off.

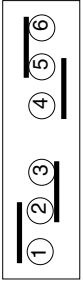

Motorized valve open, burner on, alarm off.

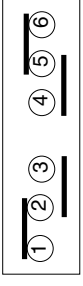

Motorized valve open, burner off, alarm on.

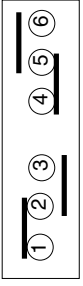

**For Models 159 and 159S**

Pump #1 off, pump #2 off.



Pump #1 on, pump #2 off.

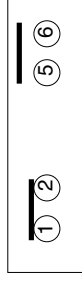

Pump #1 on, pump #2 on.



**a. Using a flathead screwdriver, remove the junction box cover (K).**

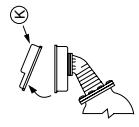

- b. Following the appropriate wiring diagram, (refer to page 9) based on your application requirements, and using BX armored cable or Thinwall electrical metal tubing connector fittings, make electrical connections to the junction box (L).

**Snap Switches (Series 150S and 157S)**

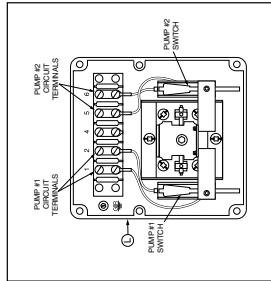
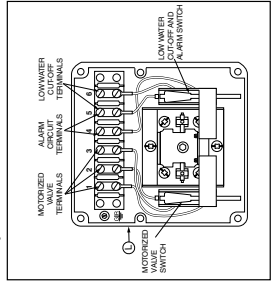
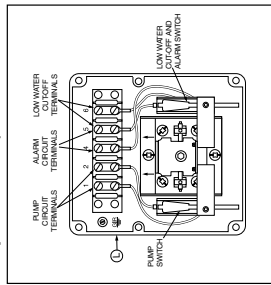

**Automatic Reset  
(All models except 158S and 159S)**

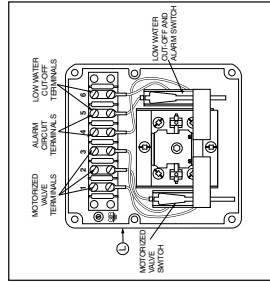
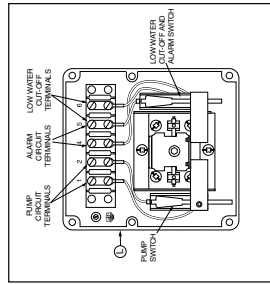

**Automatic Reset  
Model 159S**

**Manual Reset  
(All models except 158S)**

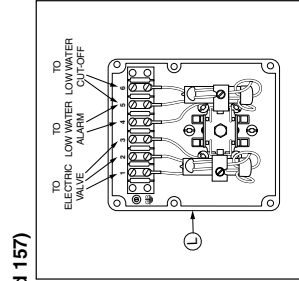
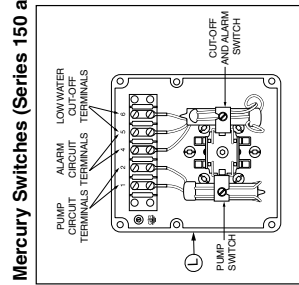

**Manual Reset  
Model 158S-M**

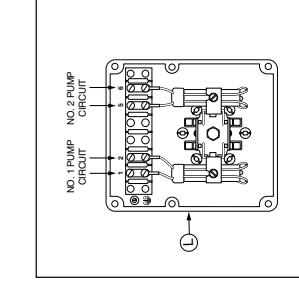

**(All models except 158 and 159)**

**Model 158**

**Model 159**

**WIRING DIAGRAMS**

For Motorized Valves, refer to the valve manufacturer's wiring instructions.

**Low Water Cut-Off Only**

1. Main Line Switch - For burner circuits within the switch's electrical rating.
2. Pilot Switch - To holding coil of a starter when the burner circuit exceeds the switch's electrical rating.

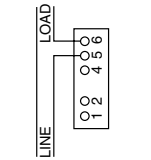

OR

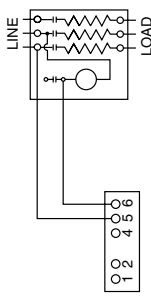

**Pump Control Only**

1. Main Line Switch - For pump motors within the switch's electrical rating.
2. Pilot Switch - To holding coil of a starter when the pump circuit exceeds the switch's electrical rating.

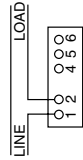

OR

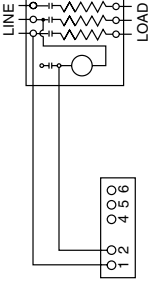

**Note:** For Models 159 and 159S, use terminals 5 and 6 for pump #2.

**Alarm Circuit Only**

1. Low Water Alarm
2. High Water Alarm

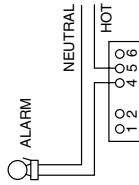

OR

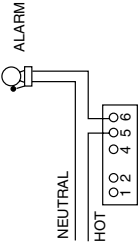

**Combination Pump Control, Low Water Cut-Off and Alarm**

1. Main Line Switch - For burner circuits within the switch's electrical rating.
2. Pilot Switch - To holding coil of a starter when the burner circuit exceeds the switch's electrical rating.

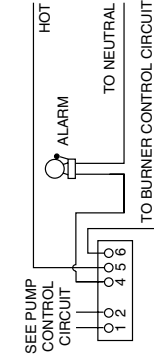

OR

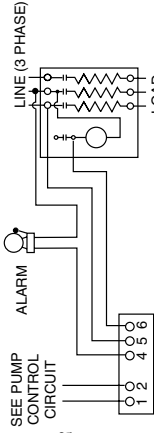

- c. Re-attach the junction box cover (K).

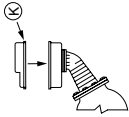

### STEP 5 - Testing

This control is factory calibrated for specific applications. The following testing procedure is only meant to serve as a verification of proper operating sequence. Dimensions provided are typical for a boiler not being fired and/or not at pressure. Actual operating ranges are shown on page 2 in the "Operation" section.

**IMPORTANT:** Follow the boiler manufacturer's start-up and operating instructions along with all applicable codes and ordinances. **Note:** Water levels stated below are only for 150 psi (10.5 kg/cm<sup>2</sup>) operation.

- a. Turn on the electric power to the boiler. With the boiler empty the pump should go on and the burner must remain off.

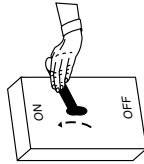

### WARNING

If the burner comes on, immediately turn the boiler off and make the necessary corrections.  
Failure to follow this warning could cause an explosion or fire and result in property damage, personal injury or death.



- b. The boiler should begin to fill with water. Watch the gauge glass (J) until the water level reaches approximately 7/8" (22mm) above the horizontal cast line (M) on the low water cut-off.

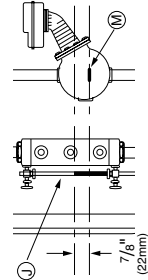

**IMPORTANT:** If water does not start filling the boiler, immediately turn off the boiler and make the necessary corrections.

- c. **For automatic reset models only.** When the water level reaches approximately 7/8" (22mm) above the horizontal cast line (lower for MD models) the burner should come on (pump #2 should shut off with Models 159 and 159S).

#### Snap Switch Models

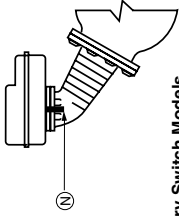

OR

- For manual reset models only.** When the water level reaches approximately 7/8" (22mm) above the horizontal cast line press the reset button (N). The burner should then come on.

#### Mercury Switch Models

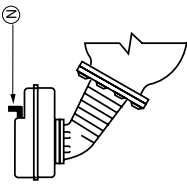

- d. Continue watching the gauge glass (J) to see that the water continues to rise to approximately 1 3/8" (35mm) (1 7/16" (37mm) for MD models) above the horizontal cast line (M). The pump should shut off (the motorized valve should close with Models 158 and 158S, or with Models 159 and 159S, pump #1 should shut off).

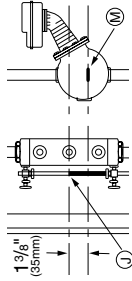

e.

### CAUTION

To prevent serious personal injury from steam pipe blow down, connect a pipe to avoid exposure to steam discharge.



Failure to follow this caution could cause personal injury.

When the water level is at its normal level and the burner is on, **Slowly** open the blow down valve (G) until it is fully open. Watch the gauge glass (H) to see that the water level drops. Close the valve after verifying that the pump comes on and the burner shuts off. For Models 158 and 158S, close the blow down valve after the motorized valve opens and the burner shuts off. For Models 159 and 159S, close the blow down valve after both pumps come on. If this does not occur, immediately shut off the boiler and correct the problem and retest.

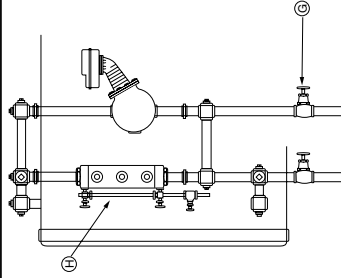

**INSTALLATION COMPLETE**

## MAINTENANCE

### SCHEDULE:

- Blow down control as follows when boiler is in operation.
  - Daily if operating pressure is above 15 psi.
  - Weekly if operating pressure is below 15 psi.

### NOTE

More frequent blow-down may be necessary due to dirty boiler water and/or local codes.

- Disassemble and inspect annually. Replace the low water cut-off/pump controller if it is worn, corroded, or if components no longer operate properly.
- Inspect the float chamber and equalizing piping annually. Remove all sediment and debris.
- Replace head mechanism every 5 years.  
More frequent replacement may be required when severe conditions exist such as rapid switch cycling, surging water levels, and use of water treatment chemicals.
- We recommend head mechanism replacement when the switch(es) no longer operate properly. If you choose to replace the switch(es), order the proper McDonnell & Miller replacement switch or switch assembly and follow the Repair Procedure provided.

### PROCEDURE:

#### CAUTION

To prevent serious personal injury from steam pipe blow down, connect a drain pipe to the control opening to avoid exposure to steam discharge.

Failure to follow this caution could cause personal injury.

1. Blow down the low water cut-off when the water level is at its normal level and the burner is on. **Slowly** open the blow down valve until it is fully open and observe the water level fall in the gauge glass. Close the valve after verifying that the pump contacts have closed and the burner shuts off. For Models 158 and 158S, close the blow down valve after the motorized valve opens and the burner shuts off. For Models 159 and 159S, close the blow down valve after both pumps come on. If this does not happen, immediately shut off the boiler and correct the problem.

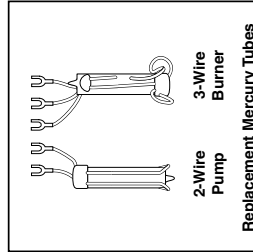
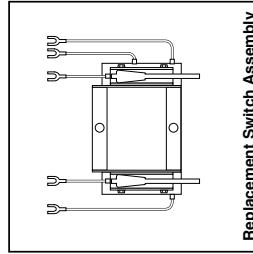

McDonnell & Miller



3500 N. Spaulding Avenue  
Chicago, Illinois 60618  
tel: 773 267-1600  
fax: 773 267-0991  
www.mcdonnellmiller.com

©2001 ITT Industries, Inc.  
Printed in U.S.A. 4-01 210341





Replacement Instructions  
MM-711

McDonnell & Miller



## Series 150, 150S, 157, 157S Bellows Replacement

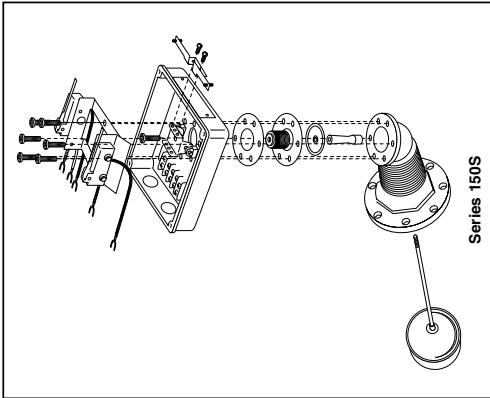

Series 150S

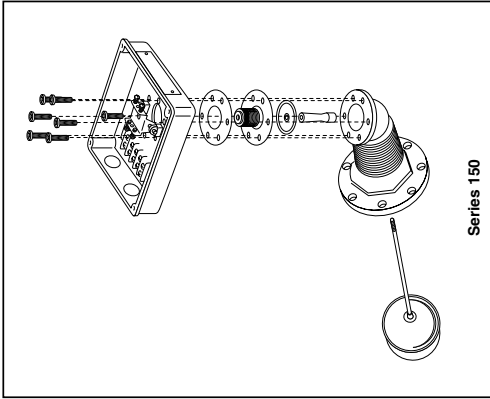

Series 150

### **WARNING**

- Before using product, read and understand instructions.
  - Save these instructions for future reference.
  - All work must be performed by qualified personnel trained in the proper application, installation, and maintenance of plumbing, steam, and electrical equipment and/or systems in accordance with all applicable codes and ordinances.
  - To prevent electrical shock, turn off the electrical power before making electrical connections.
  - To prevent serious burns release all pressure and let boiler cool down to 80°F (27°C).
  - Drain water level down below the float bowl chamber before taking the head mechanism out of the body.
- Failure to follow this warning could cause property damage, personal injury or death.



### STEP 1 - Preparation

- To prevent electrical shock turn off all electrical power to the boiler.  
**CAUTION:** There may be more than one source of power to the boiler.

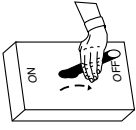

- Release all pressure from the boiler and let it cool down to 80°F (27°C). Drain the water level down below the float chamber.

- Remove the four screws that hold the cover on the switch housing (A) and remove the cover. Mark all electrical supply wires so they can be returned to the proper terminals. Remove the wires and conduit connections from switch housing (A).
- Remove eight hex head bolts holding head mechanism (B) to float chamber. Carefully remove head mechanism (B) from float chamber and place in a vise.

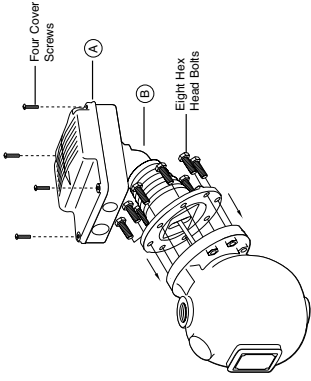

- Hold float (C) firmly, unscrew Allen® or Torx® fastener (D). (Units with date codes of E99 or earlier will have Allen® head fasteners. Those with codes of F99 or later will have Torx® fastener). Unscrew float and float rod (C). For snap switch units see Step 3a. For mercury switch units remove the two mercury switches. Remove six (6) Allen® or Torx® screws (E).

- Remove switch housing (A) from head casting (B). The bellows assembly (F) may stick to the switch housing (A). Remove bellows assembly (F) and clean gasket surfaces on both head casting (B) and switch housing (A).

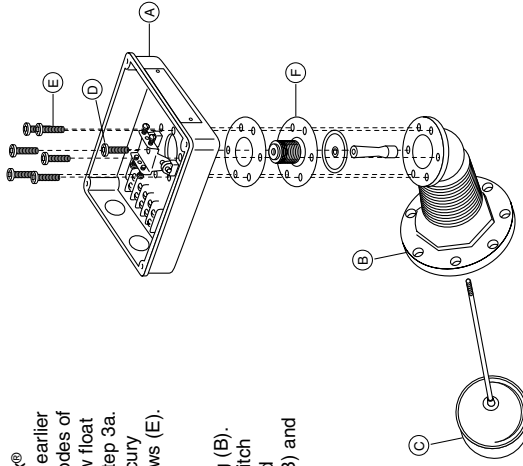

### STEP 2 - Changing the Bellows for Mercury Switch Units (For Snap Switch See STEP 3)

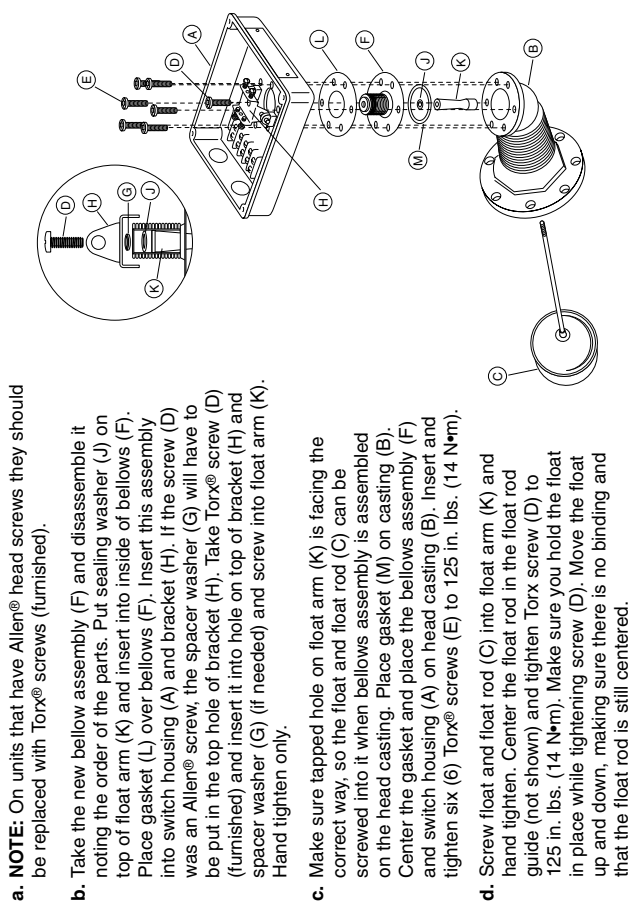

**a. NOTE:** On units that have Allen® head screws they should be replaced with Torx® screws (furnished).

**b.** Take the new bellow assembly (F) and disassemble it noting the order of the parts. Put sealing washer (J) on top of float arm (K) and insert into inside of bellows (F). Place gasket (L) over bellows (F). Insert this assembly into switch housing (A) and bracket (H). If the screw (D) was an Allen® screw, the spacer washer (G) will have to be put in the top hole of bracket (H). Take Torx® screw (D) (furnished) and insert it into hole on top of bracket (H) and spacer washer (G) (if needed) and screw into float arm (K). Hand tighten only.

**c.** Make sure tapped hole on float arm (K) is facing the correct way, so the float and float rod (C) can be screwed into it when bellows assembly is assembled on the head casting. Place gasket (M) on casting (B). Center the gasket and place the bellows assembly (F) and switch housing (A) on head casting (B). Insert and tighten six (6) Torx® screws (E) to 125 in. lbs. (14 N•m).

**d.** Screw float and float rod (C) into float arm (K) and hand tighten. Center the float rod in the float rod guide (not shown) and tighten Torx® screw (D) to 125 in. lbs. (14 N•m). Make sure you hold the float in place while tightening screw (D). Move the float up and down, making sure there is no binding and that the float rod is still centered.

### Step 3 - Changing the Bellows for Snap Switch Units

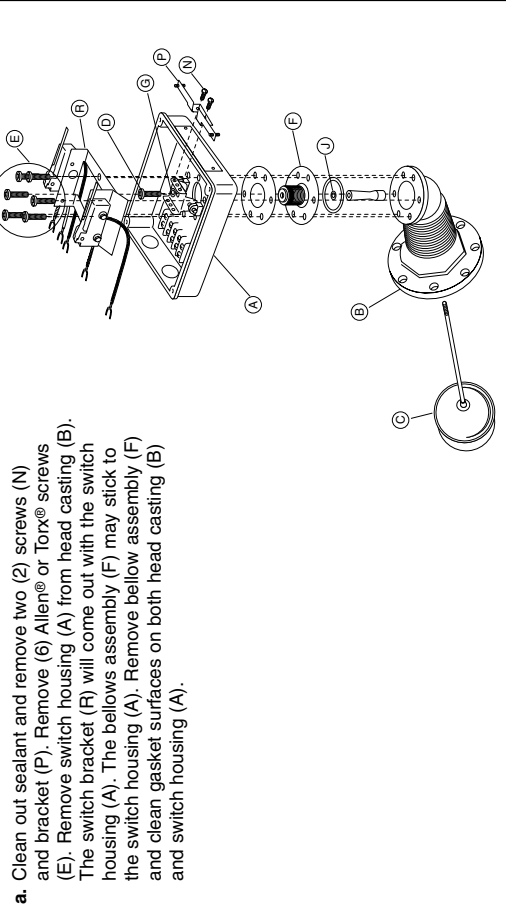

**a.** Clean out sealant and remove two (2) screws (N) and bracket (P). Remove (6) Allen® or Torx® screws (E). Remove switch housing (A) from head casting (B). The switch bracket (R) will come out with the switch housing (A). The bellows assembly (F) may stick to the switch housing (A). Remove bellow assembly (F) and clean gasket surfaces on both head casting (B) and switch housing (A).

### Step 3 - Changing the Bellows for Snap Switch Units (cont'd)

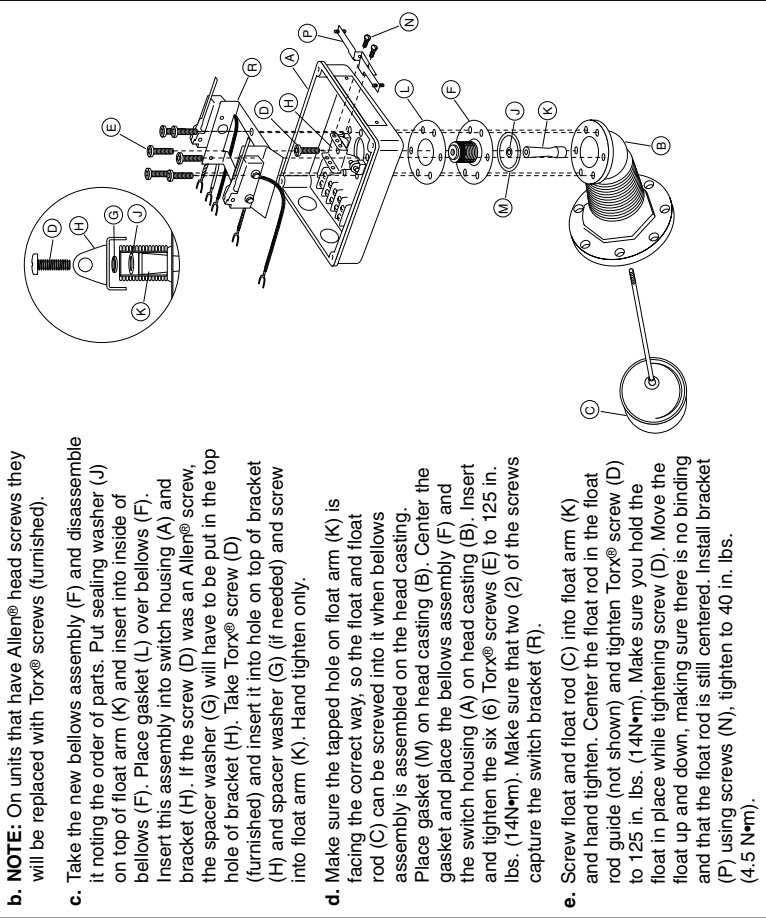

**b. NOTE:** On units that have Allen® head screws they will be replaced with Torx® screws (furnished).

**c.** Take the new bellows assembly (F) and disassemble it noting the order of parts. Put sealing washer (J) on top of float arm (K) and insert into inside of bellows (F). Place gasket (L) over bellows (F). Insert this assembly into switch housing (A) and bracket (H). If the screw (D) was an Allen® screw, the spacer washer (G) will have to be put in the top hole of bracket (H). Take Torx® screw (D) (furnished) and insert it into hole on top of bracket (H) and spacer washer (G) (if needed) and screw into float arm (K). Hand tighten only.

**d.** Make sure the tapped hole on float arm (K) is facing the correct way, so the float and float rod (C) can be screwed into it when bellows assembly is assembled on the head casting. Place gasket (M) on head casting (B). Center the gasket and place the bellows assembly (F) and switch housing (A) on head casting (B). Insert and tighten the six (6) Torx® screws (E) to 125 in. lbs. (14 N•m). Make sure that two (2) of the screws capture the switch bracket (R).

**e.** Screw float and float rod (C) into float arm (K) and hand tighten. Center the float rod in the float rod guide (not shown) and tighten Torx® screw (D) to 125 in. lbs. (14 N•m). Make sure you hold the float in place while tightening screw (D). Move the float up and down, making sure there is no binding and that the float rod is still centered. Install bracket (P) using screws (N), tighten to 40 in. lbs. (4.5 N•m).

### STEP 4 - Assembling the Head to the Body and Test for Proper Operation

**a.** Clean the gasket surface on head casting (B) and the body casting. Using a new gasket (furnished) mount the head mechanism to the body casting. Tighten the eight (8) bolts to 18 ft. lbs. (24 N•m). Reattach conduit connectors and connect wires to the proper terminals. Turn on electrical power to the boiler.

**b.** Run the unit through several cycles of operation, noting the operating points. On the snap switch controls it may be necessary to readjust the switches. If this is necessary follow the enclosed instructions. (See attached for reference only, MM-235).

McDonnell & Miller



3500 N. Spaulding Avenue  
Chicago, Illinois 60616  
Tel: 773 267-1600  
Fax: 773 267-0991  
www.mcdonnellmiller.com

©1989 ITT Industries Inc.  
Printed in U.S.A. 7-99 246765



## Wiring connections for a Series 150E/157E when used as a replacement for a Series 150/157 (mercury) or 150S/157S (snap) switch unit.

### NOTE

Read and follow installation instructions included with 150E/157E control.

- A. Connect 'Hot' (L-1) wire from power supply to Terminal 'H'.
- B. Connect 'Neutral' (L2) wire from power supply to Terminal 'N'.

**NOTE:** Power wires connected to Terminals 'H' and 'N' on 150E should be from the boiler's control transformer connections which are usually designated 'L1' and 'L2'. The 150E **SHOULD NOT** be powered as part of any operating or safety circuit.

- C. Remove wire from Terminal '1' and connect to Terminal 'PCOM'.
- D. Remove wire from Terminal '2' and connect to Terminal 'PNO'.
- E. Remove wire from Terminal '4' and connect to Terminal 'BNO'.
- F. Remove wire from Terminal '5' and connect to Terminal 'BCOM'.
- G. Remove wire from Terminal '6' and connect to Terminal 'BNO'.

Snap Switches (Series 150S and 157S)

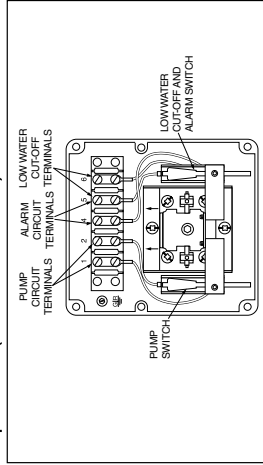

Mercury Switches (Series 150 and 157)

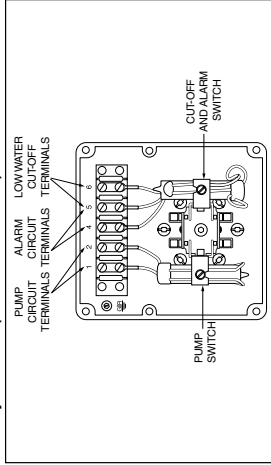

Electronic Relays (Series 150E and 157E)

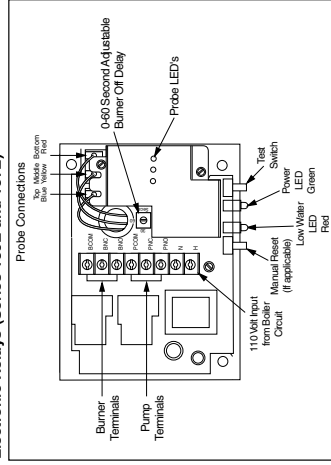

# INSTRUCTIONS FOR TUBE REMOVAL & REPLACEMENT

## TOOLS NEEDED

Current Boiler Size	Socket Size
100-750	1-1/16" socket
850-5000	1-1/4" socket
5550-9500	1-5/16" socket
10,000 + larger	1-1/16" socket
Steam Models	
5-40 HP	7/8" socket
50-70 HP	1-1/16" socket

## MATERIAL REQUIRED

2 - Replacement Head Gaskets  
 Boiler Tubes:  
 SA178 Grade A 2" Dia - 0.95" Wall  
 By Boiler Req. Length

Small pinch bar to pry head plate loose  
 Small sledge hammer (approx. 4#)  
 1" chisel 8" to 10" long

Tube cutting tool  
 1" Socket for square end of tube cutting tool (if used)  
 12" OAL ratchet for use with tube cutting tool or expander  
 Extension handle for leverage  
 Tube expander/roller-3/4" socket  
 Large drill motor for expanding/rolling of tubes  
 Test pump (if required)

## PROCEDURE

Apply WD-40 or similar oil on the studs before removing nuts.  
 Remove the head plate nuts.  
 Remove the head plates & gaskets.  
 Open the combustion chamber (fire box) door.  
 Remove or cover the burner heads (we feel that it is better to remove & clean the burner heads at this time for proper maintenance of your boiler).



Gaskets, tube rollers (expanders) & tube cutters are available for sale or rental from the factory. Please call the parts department for details.



**NOTE: DO NOT REMOVE THE FOUR "CORNER" TUBES AS THEY ARE NEEDED TO HOLD THE SHAPE OF THE BOILER.**

1. Begin by cutting the bottom row of boiler tubes.
2. Cut all other tubes from both ends of the boiler. The tubes will fall into the fire box. Do not damage the burner/gas orifices.
3. Using a dull chisel and sledge hammer, crimp down the flared end of the tube that is left in the tube sheet after cutting.
4. Using the same chisel and hammer, knock the remaining piece of tube into the fire box.
5. After removing the tube ends, clean all tube sheet holes with a grinding stone using caution not to remove too much surface or cause holes to become out of round.
6. Install four tubes into the tube sheet nearest to the remaining four corner tubes and roll (expand) those tubes using your expanding tool, socket and drill motor. Now remove the four "corner" tubes, & tube ends and clean the tube holes as per the above instructions.
7. The remaining tubes can now be installed into the tube sheet at this time.
8. Use a flat ended nail on one end to hold the tube and keep them from spinning while rolling.
9. Lightly grease the inside of the tube before rolling for lubrication of the roller (expander).
10. Expand (roll) all tubes.
11. After expanding wipe inside of tube to remove excess grease.
12. Clean inside of header and head plate.
13. Replace magnesium anode rods (if included with boiler).
14. Install new gaskets (no gasket compound is needed).
15. Install head plates and nuts.
16. Using a 12" OAL ratchet and socket, tighten the head plate nuts.
17. Refill boiler with water.
18. **Pump boiler pressure not to exceed relief valve pressure.**
19. Using a flash light, look into the fire box area and check tubes for leaks.
20. If leaks are found, drain boiler and follow above procedure to re-expand tubes(it is not necessary to remove leaking tube, only to re-roll).
21. Continue procedure until leaks are stopped.

Gaskets, tube rollers (expanders) & tube cutters are available for sale or rental from the factory. Please call the parts department for details.

## AJAX BOILER INC.

2701 SOUTH HARBOR BLVD. • SANTA ANA, CA 92704  
 PHONE: (714) 437-9050 • FAX: (714) 437-9060  
<http://www.ajoilerinc.com> • EMail: [Info@ajoilerinc.com](mailto:Info@ajoilerinc.com)

**YOUR LOCAL REPRESENTATIVE IS:**

AJAX Boiler Inc. maintains a policy of continuous improvements and therefore reserves the right to change specifications without notice.







## **N O T I C E**

This owners & operation manual provides warnings of risk of harm from improper installation, operation and/or maintenance of Ajax Products. Ajax Boiler, Inc. used ordinary care and complied with UL and ASME Standards in the design and manufacture of Ajax Products. Proper installation, operation and maintenance are covered in the manual supplied with the product. All equipment must comply with local codes.

## **W A R N I N G**

**THIS PRODUCT CONTAINS CRYSTALLINE SILICA, A CHEMICAL KNOWN TO CAUSE CANCER. CONTAINS NO ASBESTOS.**

### **AJAX BOILER INC.**

2701 S. Harbor Blvd. • Santa Ana, CA 92704

714.437.9050 • Fax 714.437-9060

[www.ajaxboiler.com](http://www.ajaxboiler.com)

[mail@ajaxboiler.com](mailto:mail@ajaxboiler.com)

SO # \_\_\_\_\_

Serial No. \_\_\_\_\_

Model No. \_\_\_\_\_