

DS Series

Ultraqua Autoclean®

Oil/Water Separators



Donaldson Ultrafilter offers two types of oil/water separators. The **DS Series** utilizes gravity to separate oil/water mixtures and purify the condensate to a residual oil content of 20 *ppm* or lower. The **Ultraqua Autoclean UFA-AC Separators**, with membrane technology, are designed to purify oil/water emulsions and oil/water mixtures to a residual oil content of 5 *ppm* or lower.

The Need for Condensate Management

Liquid condensate is generated at several points throughout a compressed air system, including the outlet of the compressor itself, within accumulator tanks, cyclone separators, coalescing filters and refrigerated air dryers. Wherever condensate forms, it must be removed from the compressed air system and discharged in a manner that is both environmentally sound and economical.

When oil is present, as with oil lubricated compressors, the condensate must be purified to legal levels of residual oil content before it can be discharged to public water treatment systems. Typically, condensate will contain on the order of 5% oil.

That level must be reduced to 20 *ppm* or lower, depending on local ordinances. Our DS Series and Ultraqua Autoclean UFA-AC oil/water separators are designed to meet or exceed those discharge levels as efficiently and economically as possible.



DS Series

The Source of Liquid Condensate

Ambient air, in addition to other substances, holds water vapor. The actual amount of water vapor present depends on many factors, including ambient temperature and relative humidity. As that air gets compressed, the water vapor gets concentrated in a smaller volume of air. A given volume of air, regardless of pressure, can hold only so much water vapor. Although temperature plays a role, the air eventually becomes saturated. Any additional water vapor present will condense out as a liquid.

The resulting liquid gets further contaminated with concentrated particles that came in with the ambient air and with oil from the compressor itself. The condensate is no longer just water and must be purified before it can be discharged to public drain systems.

The amount of condensate generated within a compressed air system can be surprising. As an example, a 500 *scfm* system operating in ambient conditions of 60°F and 65% relative humidity can generate nearly 2 gallons of liquid condensate per hour. That condensate, however, will be generated at a number of points within the system.

Condensate Collection

Within the compressed air system, and after the air has reached its saturation point, condensation will occur whenever the temperature of that air drops below the lowest temperature it has experienced after compression. For example, as the air passes through the aftercooler, condensation will begin. Although the air might exit the aftercooler at 100°F, it will continue to cool as it flows on to the accumulator tank. Condensation will occur in the pipes and in the accumulator. After the accumulator tank the air might be directed to a refrigerated air dryer. That air will carry liquid aerosols that were not collected in the accumulator tank. A coalescing prefilter will capture and concentrate those aerosols into bulk liquid that collects in the bottom of the filter housing. The refrigerated air dryer will reduce the temperature of the air to 38°F, during which time even more condensate is generated. All of this condensate must be removed from the compressed air system. This is accomplished with the use of drain valves.

Types of Drain Valves

Drain valves can be manual or automatic. Manual drains are generally ball valves or simple thumbscrew valves, while automatic drain valves can be float, timer operated or zero-air-loss type.



Donaldson Ultrafilter Ultramat UFM-T zero-air-loss drain valves prove outstanding for two reasons:

- (1) Manual and timer-operated drain valves will vent compressed air every time they open, and float style drain valves can also vent air if not properly seated. Ultramat zero-air-loss valves prevent the loss of compressed air by allowing only liquid condensate to pass.
- (2) Ultramat drain valves prevent emulsification of the condensate, which can seriously hinder the oil/water separators ability to purify the condensate.



Types of Condensate

Oil-laden condensate can exist as either a mixture or as an emulsion. In the case of a mixture, oil will separate relatively easily and quickly from water if left undisturbed.

In the case of an emulsion, the oil either already exists as, or has formed into, tiny droplets in suspension within the surrounding water.

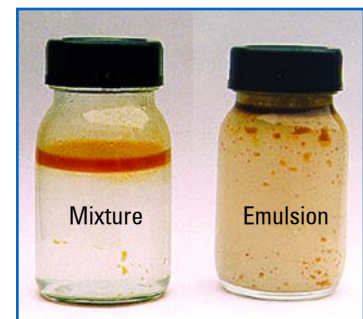

Emulsions will not separate quickly or easily as compared to mixtures.

Whether you have a mixture or an emulsion will depend on what type of oil is in the condensate or how aggressively the condensate has been handled. If overly agitated, as can occur with manual drain valves, even an oil/water mixture can become emulsified to a level where it takes a long time to settle and separate. This emulsification will reduce the efficiency of gravity type separators and significantly reduce the service life of the activated carbon bags.

A simple visual test can reveal if you have a mixture or an emulsion. Using a glass container, take a fresh sample of your condensate in the evening and let it set undisturbed overnight. In the morning, the condensate will look like one of the samples above and you will know what you're dealing with.

DS Series Oil/Water Separators



DS units are easy to install, operate and maintain. They require no power, unless fitted with an optional heater, and operate without intervention between maintenance intervals.

Features & Benefits

Optimal Sizing to Specific Installations

Seven models are available to optimally size DS separators to the requirements of the operation.

Removable Pre-sedimentation Tank

Before liquid condensate enters the large settling tank, where oil separation will take place, it first passes through a removable pre-sedimentation tank. This allows solids to separate out before they can foul the larger tank. The pre-sedimentation tank is small enough to be removed easily for cleaning.



Tapered Carbon Bag Chambers

DS Series separators utilize integrated carbon adsorbers to further purify condensate as it exits the settling tank. The chambers that hold these carbon bags are tapered for easier removal of the bags from the unit.

Pre-adsorber Protects Carbon Adsorbers

To lengthen the life of the integral carbon adsorbers, DS separators are equipped with pre-adsorbers that protect the carbon adsorbers from liquid oil and other contaminants. This prefiltration greatly enhances the life of the adsorbers.

Multiple Condensate Connection Ports

Each Donaldson DS separator allows for up to four condensate sources to be connected.

Unique Knob-adjustable Oil Drain Tray

Because oil content of condensate is not consistent from one plant to the next, DS separators incorporate an adjustable oil drain tray so that each unit can be fine-tuned to the needs of the specific facility where it is in operation. The unique design of this oil drain tray assures that the operator's hands do not come into contact with condensate while adjusting the unit.

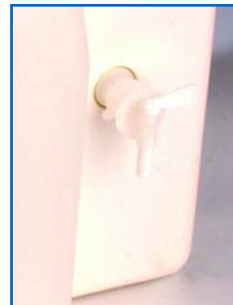

Water Purity Sample Port and Test Kit

A sample port built into DS separators allows operators to draw a small sample of purified condensate into a clear jar for comparison against an etched reference glass, all of which are included with each unit.

Optional Accessories

Thermostat Controlled Heater

If the DS separator is installed in an area where the ambient temperature might go below 34°F, use the optional thermostat-controlled heating unit to prevent freezing of the condensate.

Condensate Distribution Manifolds

Often more than one separator will be required to meet the needs of a given operation. In those instances, distribution manifolds are available to assure that condensate is evenly distributed among the connected oil/water separators.

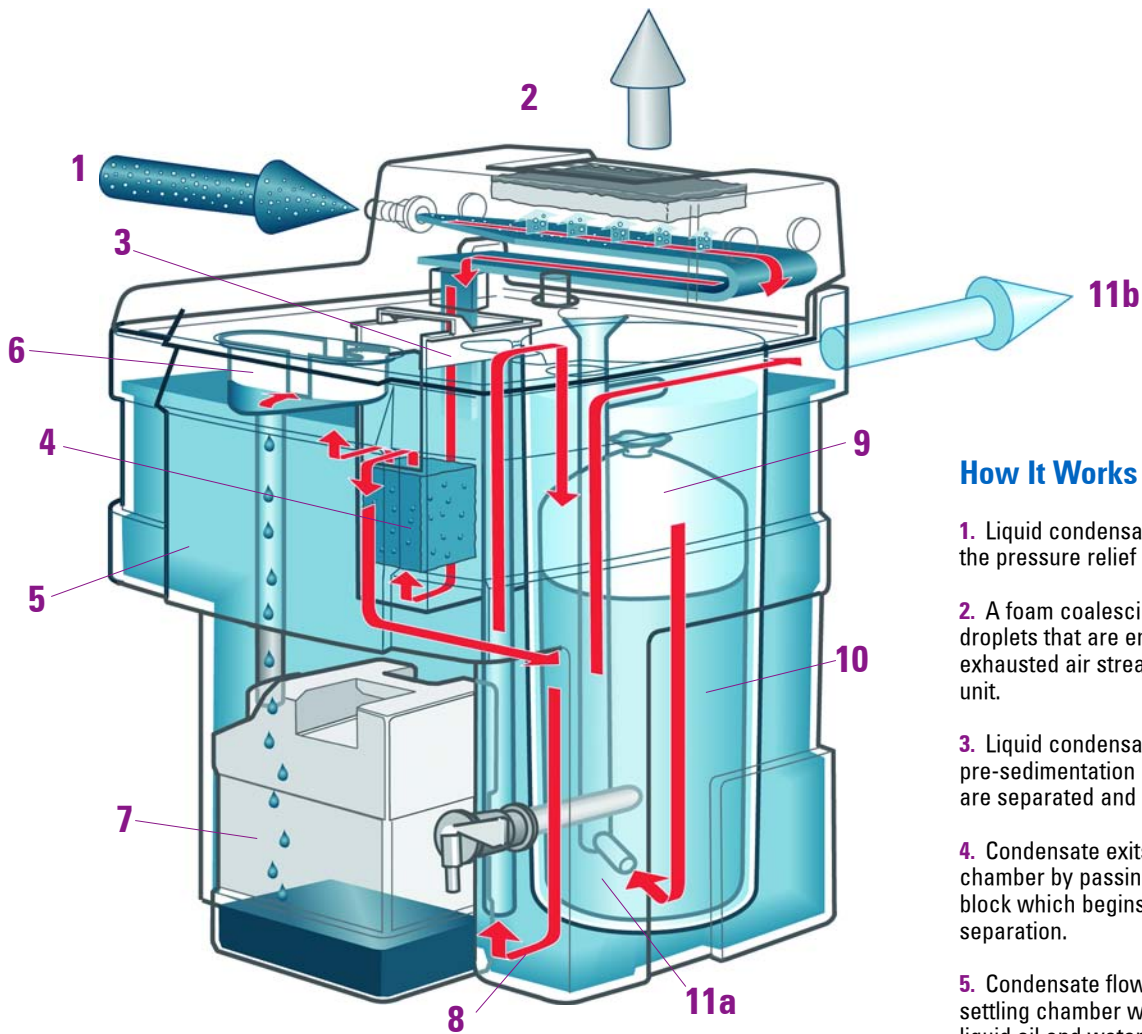

How It Works

1. Liquid condensate and compressed air enter the pressure relief chamber at the top of the unit.
2. A foam coalescing pad captures condensate droplets that are entrained in the expanding and exhausted air stream, which exits the top of the unit.
3. Liquid condensate enters a removable pre-sedimentation chamber where solid particles are separated and captured.
4. Condensate exits the pre-sedimentation chamber by passing through a coalescing foam block which begins the process of oil-water separation.
5. Condensate flows into and fills the primary settling chamber where gravity separation of liquid oil and water takes place.
6. Separated oil is skimmed from the surface of the settling chamber through an adjustable oil drain tray.
7. Oil is captured in a removable container and held for proper disposal.
8. Separated water is drawn from the bottom of the settling chamber for final purification.
9. Separated water flows downward through a pre-adsorber that captures additional oil and protects the carbon bag(s) that follow.
10. Activated carbon removes oil to a residual level of 20 ppm or lower. Depending on the size of the unit, one or two carbon adsorption chambers will be present.
- 11a. Purified water is drawn from the bottom of the carbon adsorption chamber and then either exits the unit (11b) or passes into the second carbon adsorption chamber if present.

Sizing

Consider these factors when sizing an oil/water separator:

- The capacity of the compressed air system itself
- The type of compressor in use
- The type of lubricant used by the compressor
- Whether or not a refrigerated air dryer is in use
- Ambient temperature
- Relative humidity

The risk from over-sizing an oil/water separator is that a little more money will have been spent when not necessary. The risk from under-sizing an oil/water separator is more significant: without enough residence time in the unit, oil will not separate to the required purity levels and/or the unit will have to be serviced too frequently.

See model selection guidelines on page 8.



Ultraaqua Autoclean® UFA-AC



Using membrane technology, Ultraaqua systems purify oil/water emulsions and oil/water mixtures to a residual oil content of 5 ppm or lower.

If your process requires purification of an emulsion, or if your condensate mixture must be purified to lower levels of residual oil content than achievable by the Donaldson DS oil/water separator, choose an Ultraaqua Autoclean UFA-AC membrane-based oil/water separator. These units have been designed to purify condensate to a guaranteed residual oil content of 5 ppm or less.

Features & Benefits

- Residual oil content of 5 ppm or less from oil/water emulsions or mixtures
- Separates emulsions without the use of chemicals
- Autoclean automatic regeneration minimizes operating costs by delaying regeneration until required
- Durable ceramic membrane
- Viton® seals throughout
(Viton® is a registered trademark of DuPont Dow Elastomers)
- Continuous monitoring of system temperature to minimize energy consumption and provide frost protection of membrane.
- 8 models allow optimal sizing of Ultraaqua separators to the requirements of any operation.



Ultraaqua Autoclean® UFA-AC Oil/Water Separators						
Model Number	Compressor Size Match		Dimensions in Inches			Power kW
	HP/cfm (Moderate)	HP/cfm (Tropical)	Height	Width	Depth	
0008	100/500	50/250	59	30	31	0.75
0016	200/1000	100/500	59	30	31	0.75
0032	400/2000	200/1000	63	59	31	1.5
0064	800/4000	400/2000	68	59	31	1.85
0096	1200/6000	600/3000	47	63	35	2.2
0128	1800/8000	900/4000	73	78	43	5.5
0192	2600/12000	1300/6000	73	78	43	7.5
0256	3600/16000	1800/8000	76	78	47	11

How It Works

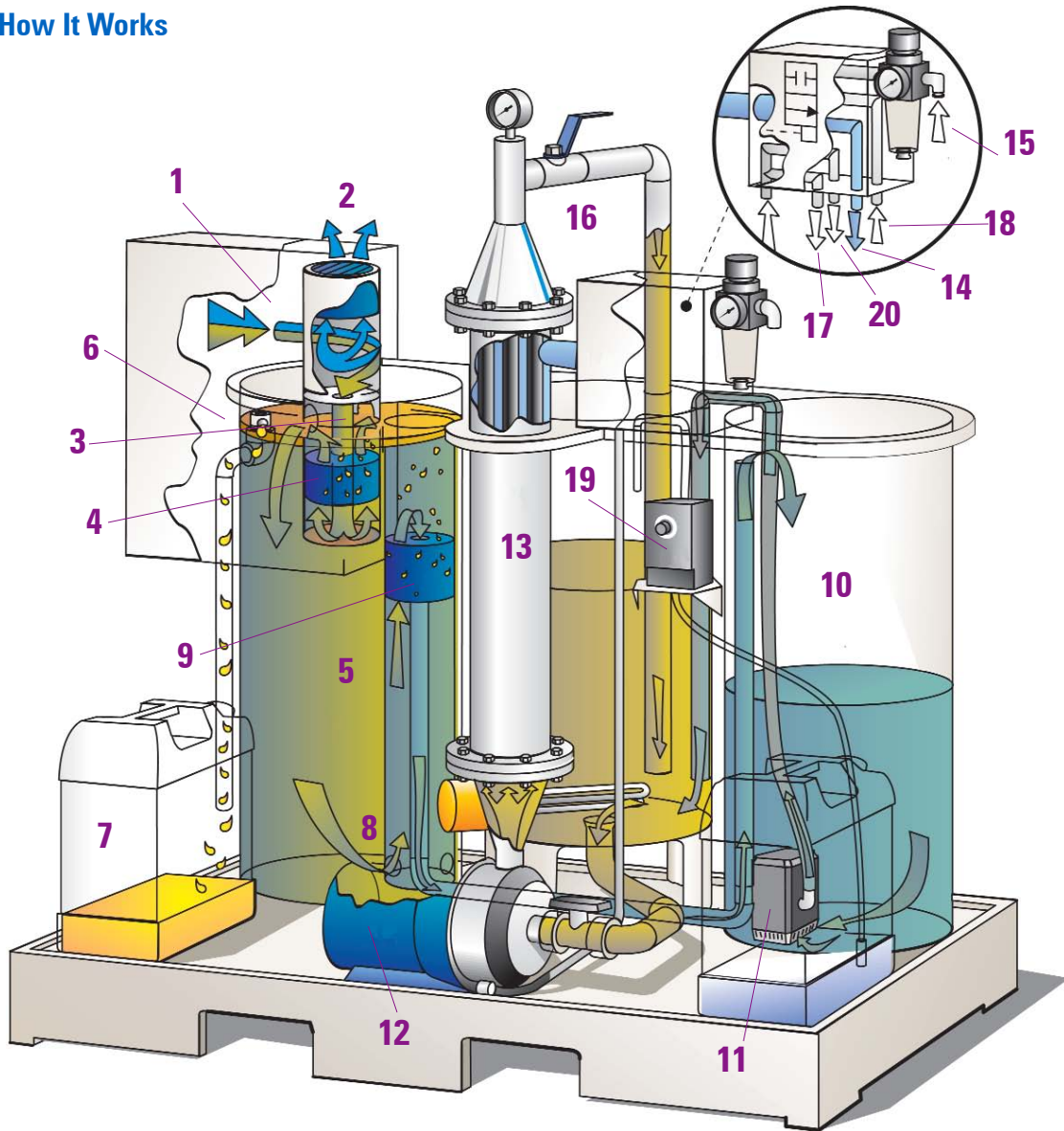

1. Liquid condensate and compressed air enter the pressure relief chamber at the top of the unit.
2. A foam coalescing pad captures condensate droplets that are entrained in the expanding and exhausted air stream, which exits the top of the unit.
3. Liquid condensate enters a removable pre-sedimentation chamber where solid particles are separated and captured.
4. Condensate exits the pre-sedimentation chamber by passing through a coalescing foam block which begins the process of oil-water separation.
5. Condensate flows into and fills the secondary settling chamber where gravity separation of liquid oil and water takes place.
6. Separated oil is skimmed from the surface of the settling chamber.
7. Oil is captured in a removable container and held for proper disposal.
8. Pre-separated condensate that remains emulsified flows from the bottom of the secondary settling chamber.

9. Condensate passes through a secondary coalescing filter to assist in further separation of oil and water before the final separation stage.
10. Condensate flows into and fills a buffer tank.
11. A pump within the buffer tank transfers pre-separated condensate into the process tank.
12. The process pump draws emulsified condensate from the process tank and pumps it into the membrane separation module.
13. Water passes through the membrane, leaving behind condensate with a higher concentration of oil.
14. Purified water with a residual oil content of 5 ppm or lower exits the system.
15. Periodically, a valve opens to allow compressed air to force purified water back through the membrane module. This back-flushing significantly increases the interval between regeneration cycles.

16. Concentrated oil/water emulsion exits the top of the membrane module and flows back down into the process chamber. The concentration of oil within the process chamber steadily increases, reducing the separation of water through the membrane.
17. Based on predetermined settings, a valve opens to drain concentrate from the process tank prior to an automatic regeneration cycle. The concentrate is pumped into a separate container for storage and proper disposal.
18. A valve opens to allow clean water to flow into the empty process tank.
19. A metering pump mixes a cleaning agent with the water flowing into the process tank. This cleaning fluid is then circulated through the membrane module.
20. At the end of the cleaning cycle, the cleaning fluid is discharged from the system through a valve. The unit is ready to begin another cycle of oil-water separation.

DS Series Oil/Water Separators Model Selection Tables

DS Model	Dimensions in Inches			Volume in Gallons				Ship Weight Lbs.
	Height	Width	Depth	Vessel	Pre-adsorber	Activated Carbon	Oil Container	
DS0070	22	14	13	6.6	0.24	0.8	0.7	19
DS0145	26	18	17	13.2	0.85	2.1	1.3	43
DS0265	29	20	18	19.8	1	3.2	2.6	52
DS0530	33	27	20	39.6	1.3	2 x 2.9	5.3	77
DS1060	39	31	26	79.2	1.5	2 x 4	5.3	150
DS2120	39	70	26	159	2 x 1.5	4 x 4	2 x 5.3	300
DS4240	39	148	26	317	4 x 1.5	8 x 4	4 x 5.3	600



Maximum Compressor Capacity -- CFM								
DS Model	Screw & Rotary Compressors with Oil Injection Cooling				Piston Compressors			
	Moderate Climates		Tropical Climates		Moderate Climates		Tropical Climates	
	Mineral Oil	Synthetic Oil	Mineral Oil	Synthetic Oil	Mineral Oil	Synthetic Oil	Mineral Oil	Synthetic Oil
DS0070	71	71	35	35	71	71	35	35
DS0145	147	147	106	71	147	106	71	71
DS0265	282	212	176	176	212	177	106	106
DS0530	565	424	389	283	424	353	247	247
DS1060	1131	848	742	495	848	707	495	459
DS2120	2262	1696	1519	1131	1696	1413	954	954
DS4240	4523	3392	3004	2262	3392	2827	1943	1873



Donaldson Company, Inc.
Compressed Air & Gas
3070 Business Park Drive
Suite 3070-B
Norcross, GA 30071 USA

©2005 Bulletin No. UFSB0129
6-2005

Toll free: 800.543.3634
Telephone: 770.448.3363
Telefax: 770.448.3854
E-mail: ultrafilterinfo@mail.donaldson.com
Web: www.donaldson.com



Mexico 01-800-343-3639; Brazil 0-800-891-9145; Puerto Rico 1-888-621-0206