

The registration card at the bottom of this page must be completed by the Amvic Representative prior to the presentation of this binder. If you move, please complete the remaining card and mail it to Amvic Head Office.

We've Moved

Please Update my address in your files.



Please Print

Name: _____ Title: _____

Company: _____

Address: _____

City: _____ State/Province: _____ Zip / Postal Code: _____

Telephone: _____ Fax: _____

Email: _____

Registration Information



Please Print

Name: _____ Title: _____

Company: _____

Address: _____

City: _____ State/Province: _____ Zip / Postal Code: _____

Telephone: _____ Fax: _____

Email: _____





Amvic Inc.
501 McNicoll Ave.
Toronto, ON
M2H 2E2



Amvic Inc.
501 McNicoll Ave.
Toronto, ON
M2H 2E2



Preface

Amvic recognizes and appreciates the important role Architects and Specifiers play in transforming ideas into real projects. This manual has been created to help you meet your unique needs during this process.

If any of your questions or concerns are not completely addressed, please attend one of Amvic's training seminars, AIA/CES programs (check your local area for schedule) or feel free to contact us and our staff will be happy to answer your questions. At Amvic, we pride ourselves in offering an exceptional level of customer service.

Technical Support

Please contact us for any inquiries pertaining to information included in this manual or if you require other technical assistance.

Technical Support 1-877-470-9991 (toll free)
1- 416-410-5674 ext. 129

Amvic Website

The Amvic website is updated regularly with the most current news including testing reports, technical bulletins and evaluation reports. This technical and installation manual is posted on the website.

Amvic website – www.amvicsystem.com



Disclaimer

This document is provided for informational purposes only. The information contained in this document represents the current view of Amvic Inc. on the issues discussed as of the date of publication. These opinions as expressed, should not be interpreted to be a commitment on the part of Amvic Inc. and cannot guarantee the accuracy of any information presented after the date of publication. The user assumes the entire risk as to the accuracy and use of this document.

This manual is intended to supplement rather than replace the basic construction knowledge of the construction professional. All structures built with the Amvic Building System must be designed and erected in accordance with all applicable building codes and/or guidance of a licensed professional engineer. In all cases, applicable building code regulations take precedence over this manual.

INFORMATION CONTAINED IN THIS DOCUMENT IS PROVIDED “AS IS” WITHOUT ANY WARRANTY OF ANY KIND, EITHER EXPRESSED OR IMPLIED, INCLUDING BUT NOT LIMITED TO THE IMPLIED WARRANTIES OF MERCHANTABILITY, FITNESS FOR A PARTICULAR PURPOSE AND FREEDOM OF INFRINGEMENT.



Table of Contents

	PAGE
Part 1 – Introduction	1
1.1 – Amvic Insulated Concrete Forms (ICFs)	1
Part 2 – Construction Overview	5
2.1 – Amvic ICF 10 Step Construction Guide	5
Part 3 – Designing with Amvic	11
3.1 – Introduction to Designing with Amvic ICF	11
3.2 – Amvic Design Software	11
3.3 – Applications	12
3.4 – Design Flexibility	13
3.5 – Design Constraints	15
3.6 – Block Sizes	15
3.7 – Wall Dimensions	16
3.8 – Combining Materials	17
3.9 – Foundations	17
3.10 – Windows & Doors	20
3.11 – Plumbing & Electrical	22
3.12 – Attachment to Walls	24
3.13 – Floors & Roofs	27
3.14 – Special Applications	29
3.15 – Concrete Specification	30
3.16 – Steel Reinforcement for Walls	30
3.17 – Lapped Splices for Multiple Concrete Pours	35
3.18 – Designing Reinforcing Steel for Walls	36
3.19 – Steel Reinforcing Bars and Jobsite Safety	38
3.20 – Preferred Coursing & Corner Dimensions	40
Part 4 – Product Specifications	49



Part 5 – CSI Specifications	51
Part 6 – Engineering	65
6.1 – ICF Engineering	65
6.1.0 – Canada	65
6.2.0 – USA	74
Part 7 – Approvals & Evaluations	95
7.1 – Amvic ICF – Technical Testing	95
7.2 – List of Code Approvals	96
7.3 – CCMC Report	97
7.4 – ICC Report	111
Part 8 – Special Topics	117
8.1 – Utility Service Installations	117
8.2 – Below Grade Moisture Protection	123
8.3 – Termites and ICF Construction	129
Part 9 – ICF FAQs	145
9.1 – Amvic ICF	145
9.2 – Why Amvic is Better	145
9.3 – Construction	146
9.4 – How To	148
9.5 – External Finishes	150
9.6 – Architectural/Engineering	150
9.7 – Cost & Performance	151
9.8 – Health & Safety	152
Part 10 - Warranty	153
Appendix A – CAD Drawings	155



Part 1 – Introduction

1.1 – Amvic Insulated Concrete Forms (ICFs)

Amvic insulated concrete forms (ICFs) are hollow, lightweight forms manufactured using two 2½ inch (63.5mm), 1.5lbs/cu.ft density expanded polystyrene (EPS) panels which are connected by uniquely designed, high impact polypropylene webs. During construction, the forms are stacked then filled with concrete making stable, durable and sustainable walls.

Amvic ICFs combine the insulating effectiveness of EPS with the thermal mass and structural strength of a reinforced concrete wall. They also offer a “5 in 1” solution that provides structure, insulation, vapor barrier, sound barrier and attachments for drywall and exterior siding in one easy step.

Walls constructed with Amvic ICFs can provide a fire rating of 3+ hours [6, 8 and 10 inch (150mm, 203mm and 254mm) walls], a sound transmission class (STC) of 50 (some wall assemblies exceed this value) and an insulation value of R-22+. By combining the performance R-value of EPS, the stabilizing effects of concrete thermal mass and the reduced air infiltration rates, Amvic ICF walls can perform up to an equivalent insulation value of R-50.



Figure 1.1 – Amvic ICF products



Figure 1.2 – Typical Amvic reversible ICF block

The webs used in Amvic ICF eliminate the need for tie downs and place reinforcing steel most effectively to ensure superior structural strength. The webs are manufactured using more raw material than competing products allowing for superior finishing capabilities and 198 lbs pull out strength for drywall screws. They are also spaced 6 inch (152mm) on center compared to 8 inch (200mm) on center resulting in greater rigidity, which keeps walls straight and plumb during stacking and the pouring of concrete.



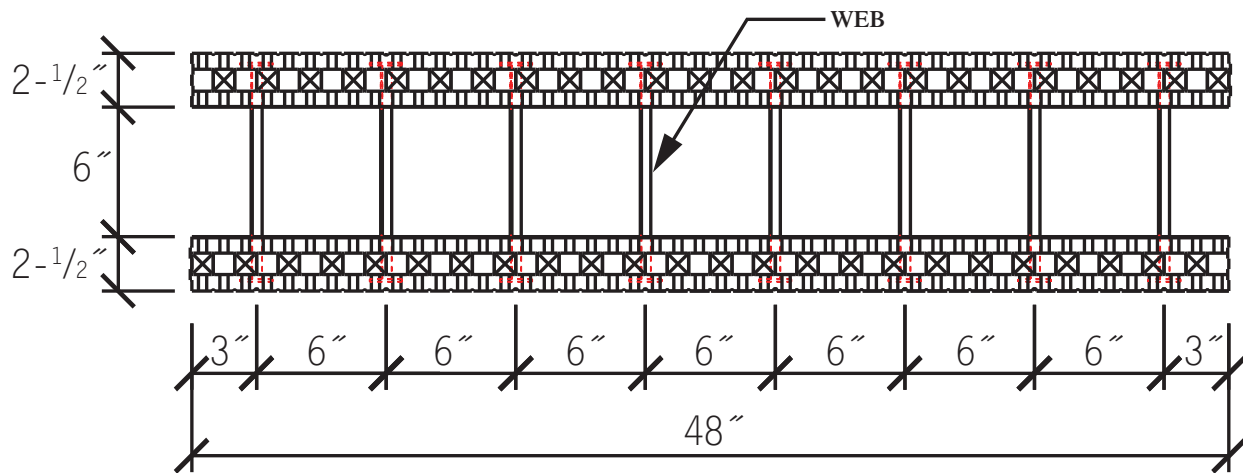

Figure 1.3 – Typical Amvic straight ICF block [6" (150mm) shown]

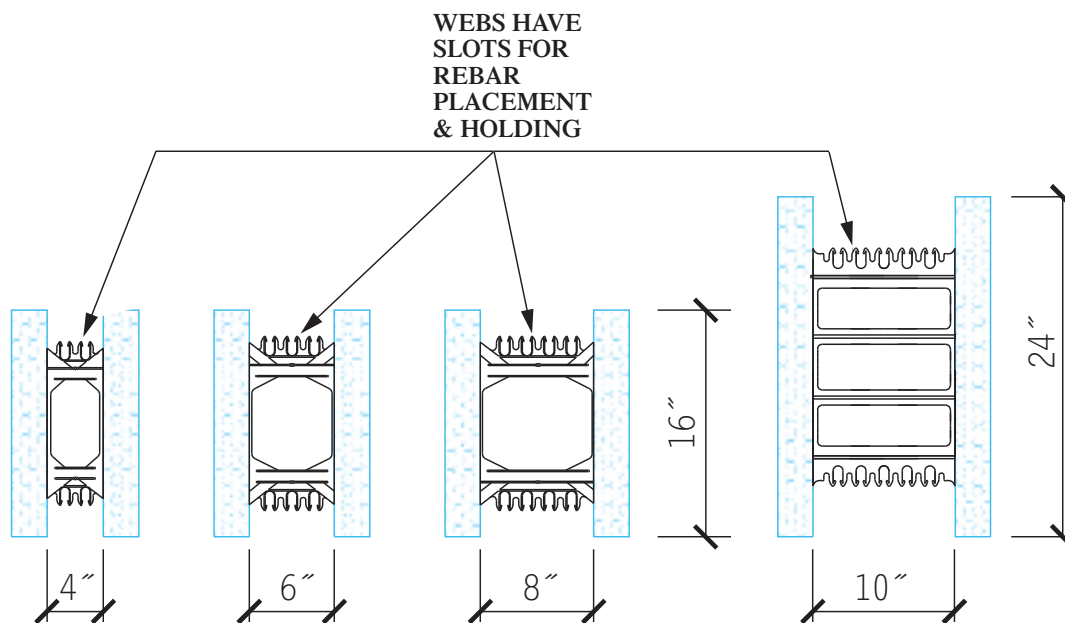

Figure 1.4 – Cross section of Amvic ICF blocks

Amvic webs connect the EPS panels and terminate with a 1½ inch (38mm) flange which is embedded ⅝ inch (16mm) beneath the outside surface of the panels. The flange has a height of 15 inches (381mm) in all blocks except the 10 inch (254mm) block which has a flange height of 23 inches (584mm). When the Amvic blocks are stacked, the flanges form a continuous horizontal and vertical grid which is used to attach interior finishes like drywall and exterior finishes like stucco, wood siding and brick veneer. (Please refer to the interior and exterior applications sections of this manual for more details.)



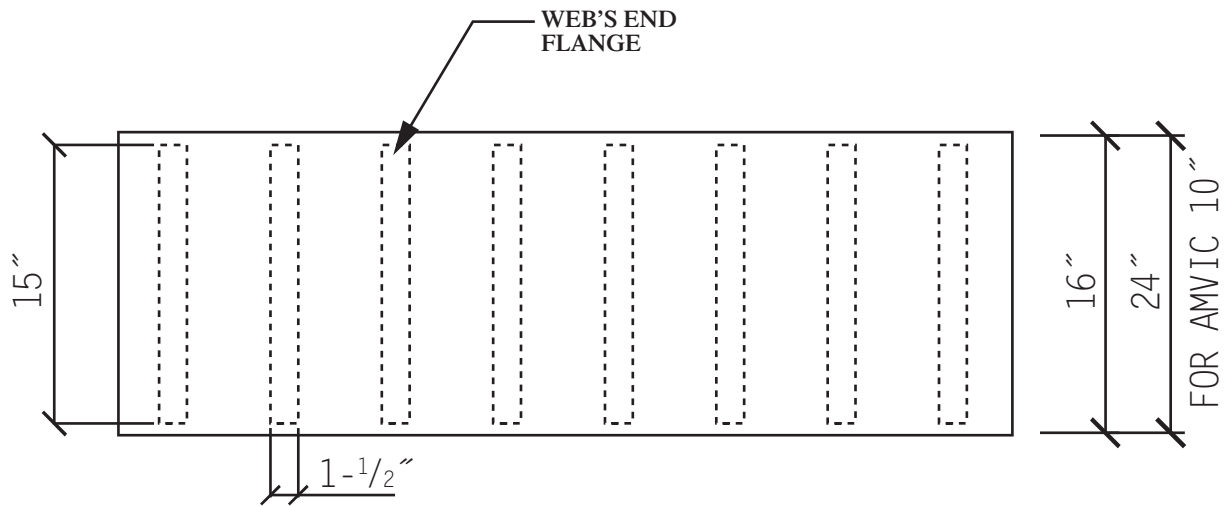

Figure 1.5 – Side view of Amvic ICF straight block showing web flanges

Amvic ICF blocks use the FormLock™ interlocking system developed by Amvic, which has considerably deeper grooves than competing products. The interlock exists on all edges allowing the blocks to be fully reversible. It also secures the courses together, preventing any movement or leakage during the concrete pour. This unique feature allows Amvic ICF to be stacked quickly, easily and without the need for glue or ties. Amvic’s user friendly, easy to install system increases job site efficiency and worker productivity which saves time and money.

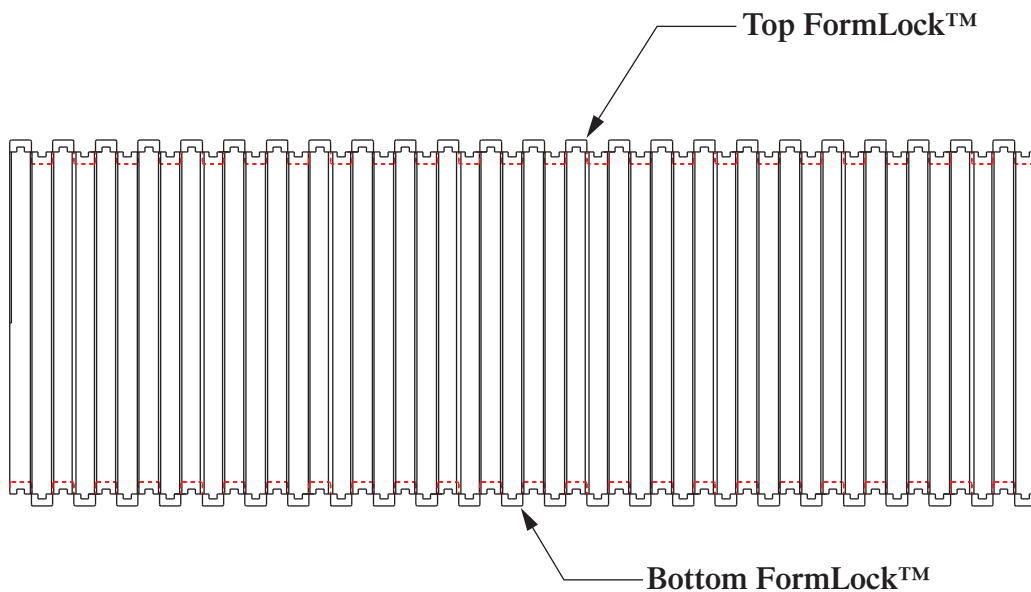

Figure 1.6 – Side view of Amvic straight block showing top and bottom interlocking system



Amvic ICFs are available in a variety of sizes allowing for concrete cores of 4, 6, 8 or 10 inches (100, 152, 200, 254mm). Straight, 90-degree corner, 45-degree corner and curved forms are available in most sizes.

Amvic 90-degree corner blocks have a pocket where a square polypropylene tube (corner rod) can be inserted. Its purpose is to provide a nailing point for mechanical attachments such as sheetrock, lathe or siding which would otherwise not exist in the EPS panel.

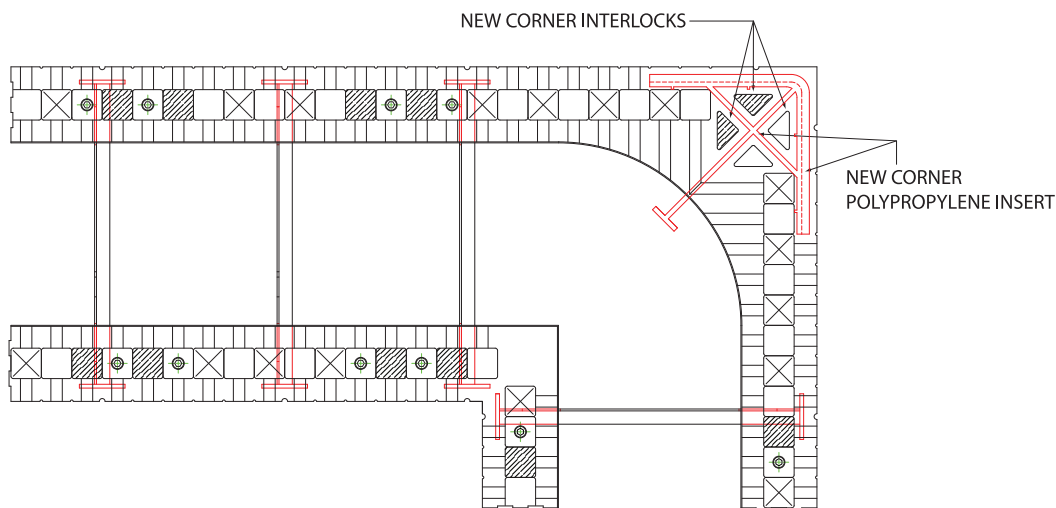

Figure 1.7 – New corner insert for 6 & 8 inch (150 & 203mm) 90 degree forms

Amvic is the best ICF system available on the market today. Competitive pricing, extensive product distribution and professional technical support are combined to provide customers with a superior product with an installation cost less than comparable systems.



Part 2 – Construction Overview

2.1 – Amvic ICF 10 Step Construction Guide

Step 1 - Plan the outline of the block and the location of door and window openings on a conventional footing or a slab that is level, straight and square. Reinforcing steel dowels should extend upward from the footing into the cavity of the block or as per engineering and/or local code requirements.



Figure 2.1 – Outlining walls

Step 2 - Place the first corner blocks on each corner, then lay the straight blocks toward the center of each wall segment. On the first course, use zip-ties or wire ties on the webs to connect the blocks and pull them snugly together. Following this, install horizontal steel reinforcement by placing it in the clips at the top of the internal webs within the block cavity. The clips hold the reinforcing steel securely and eliminate the need for wire tying. (Repeat this process for each course of block).





Figure 2.2 – Placing corner blocks first



Figure 2.3 – Installing horizontal reinforcing steel and lap splicing

Step 3 - Install the second course of ICF by reversing the corner blocks, so that the second course of block is offset from the first, in a running bond pattern. At this point check for level across all of the blocks. If the courses are not level, use shims or trim the block as required.



Figure 2.4 – Installing second course of ICF



Step 4 - Install window & door frames (“bucks”) at each location where an opening is required; cut and fit the Amvic blocks around them. Bucks are used to hold back the concrete and stay in place permanently providing a nailing surface for the installation of windows and doors. Pressure-treated lumber or vinyl bucks may be used.



Figure 2.5 – Installing window and door bucks

Step 5 - Install additional courses of block by continuing to overlap the courses so that all joints are locked both above and below by overlapping blocks.



Figure 2.6 – Continuing installing block courses



Step 6 - Install alignment bracing around the entire wall of the structure to ensure that the walls are straight and plumb and to enable alignment adjustment before and during the pour. The bracing also serves the dual purpose of providing a secure and safe framework to support scaffolding planks once five courses have been stacked.



Figure 2.7 – Installing alignment and bracing system around the perimeter of the wall

Step 7 - Stack the block to the full wall height for single storey construction, or to just above floor height for multi-storey construction. Cut the vertical reinforcing steel to length and begin installing it from the opening at the top of the wall, through the spaces between the horizontal reinforcing steel.



Figure 2.8 – Install vertical reinforcing steel after top course of blocks



Step 8 - Pour the concrete into the stacked walls using a boom pump. Do this in lifts approximately 3-4 ft (0.9-1.2m) at a time, circling the structure until the top of the wall is reached. Next, use a mechanical pencil vibrator (stinger) to vibrate the concrete and remove all air pockets within the wall. Up to one storey can be poured each day using this method.



Figure 2.9 – Pouring concrete in lifts of 3-4 ft (0.9-1.2m)

Step 9 - Screed off the concrete until it is even with the block top and then “wet set” anchor bolts into the concrete top. These bolts will be used later to install the top plate (mud sill) for the installation of rafters or trusses.





Figure 2.10 – Wet set anchor bolts in top course of upper floor

Step 10 - Remove bracing after the concrete has cured, then proceed with further stages of construction.



Part 3 – Designing with Amvic

3.1 – Introduction to Designing with Amvic ICF

3.1.1 – Residential

Amvic ICF walls for residential applications may be designed using the following codes/standards:

1. Prescriptive Method for Insulating Concrete Forms in Residential Construction – USA
2. Section R404.4 and R611 of the International Residential Code 2003 – USA
3. Part 9 of the National Building Code of Canada 2005 (adopted or adapted by the local provincial building codes) – Canada

3.1.2 – Commercial

Amvic ICF walls for commercial applications may be designed using the following codes/standards:

1. Chapter 16 of the International Building Code 2003 in conjunction with ACI 318 standard – USA
2. Part 4 of the National Building Code of Canada 2005 in conjunction with CSA A23.3 – Canada



Important Note

Codes and standards are continuously being updated. It is the design engineer's responsibility to ensure they are always using the latest edition of the code/standard in design calculations.

3.2 – Amvic Design Software

Amvic has recently developed industry leading engineering software for checking the structural adequacy of Amvic ICF walls, lintels and the AmDeck Floor & Roof System™. The software is an extremely useful tool for engineers and architects who need to streamline their design process and increase efficiency.

The software is visually interactive and any changes or inputs made by the user are automatically reflected on the graphic results in real-time. The software also has



built-in text and graphic reports output for complete transparency on the analysis and design checks performed.

For more information about the Amvic Design Software (ADS) please contact Amvic or your local distributor.

3.3 – Applications

3.3.1 – Residential

For residential construction, ICFs are typically used for the structure's exterior walls from foundation to top plate, including basements. ICFs can also be used in combination with conventional stick frame or panel construction.



Fig. 3.1 – A custom home being constructed with Amvic ICF



3.3.2 – Commercial

For commercial construction ICFs are used for the structure's exterior walls but also often for interior walls to provide shear walls or acoustic, thermal and fire barriers between areas. ICFs are generally used for structures up to 10 stories in height, subject to engineering considerations.



Fig. 3.2 – A multi-storey hotel being constructed with Amvic ICF

3.4 – Design Flexibility

Amvic ICFs provide maximum design flexibility for the designer. Some of the benefits are listed below:

- Amvic ICFs have superior engineered spanning capabilities, making long window and door insulated lintels, as well as grade beam applications easily achievable.
- More glass can be used than in a wood or steel framed structure without compromising energy code requirements due to the high R-value of the ICF wall (R-22+).





Fig. 3.3 – An ICF wall with several window openings during construction

- The inherent high shear value in a concrete wall provides added design freedom with regard to large wall openings that could be problematic in frame construction.
- The specification of concrete strength and rebar eliminates hold downs, shear panels, and most of the steel that is necessary in frame construction.
- Curved walls of nearly any radius can be built without difficulty.



Fig. 3.4 – A curved ICF wall during construction



- Non-linear fenestrations, colonnades, archways, etc. are easily constructed at a lower premium than with frame construction.
- Any exterior and interior wall coverings are easily attached, dramatically improving a structure's appearance.

3.5 – Design Constraints

Amvic ICFs maximize design flexibility; however, there are a few design constraints which are listed below:

- While wood frame and ICF concrete walls can be combined within a structure, the ICF walls must always be supported by either concrete or structural steel. Concrete walls cannot be permanently supported by wood framing.
- Cantilevering of upper stories is difficult since the support for an upper wall of concrete must either be borne by steel frame, or by transferring the load from the sidewalls. The load cannot be borne by a conventional wood floor joist system.
- One of the benefits of ICF construction is a tighter structure with significantly lower air infiltration. To ensure proper fresh air exchanges and humidity control, it is important to provide proper ventilation, such as mechanical air exchange.

3.6 – Block Sizes

Amvic provides four sizes of block which are referenced by the thickness of concrete core. The four thicknesses are 4, 6, 8 and 10 inch (100, 150, 203 and 254mm). In each case the blocks have 2-1/2 inches (63.5mm) of expanded polystyrene on each side for total thicknesses of 9, 11, 13, and 15 inches (228, 279, 330 and 381mm) respectively.

For above grade applications, the most commonly used block size is 6 inch (150mm). For below grade, the 8 inch (203mm) block is most commonly used. Occasionally, 10 inch (254mm) block is specified for tall retaining walls.



3.7 – Wall Dimensions

3.7.1 – Wall Heights

To reduce construction time, costs and wastage, it is advantageous to design a structure's wall heights to accommodate the standard form heights. Please see Section 3.20 for Preferred Coursing & Corner Dimensions.



Tip

Amvic recommends that designers use appropriate symbols to clearly identify which walls are ICF as well as scale the walls to reflect the 9, 11, 13, or 15 inch (228, 279, 330 and 381mm) thicknesses.

3.7.2 – Wall Lengths

Significant compromises to a structure's design to accommodate the block for wall lengths are not recommended. Draw the plan to work within good design practices. Amvic forms can easily be adjusted to accommodate the drawing. In most cases, Amvic ICF can be cut to almost any size desired and the majority of cutoff pieces can be reused within the walls, which can reduce waste to less than 1%.



Important Note

Since ICF walls are thicker than conventional walls, remember to increase outer dimensions to ensure you achieve the desired internal dimensions.



Tip

Consider laying out building dimensions, windows, and doors to correspond with modular dimensions of the ICF materials being used. This design investment can provide savings in labor and reduce waste, particularly for drawings that will be used repeatedly.



3.8 – Combining Materials

3.8.1 – Mixing Block Sizes

Different block sizes can be combined either on subsequent levels or on different wall faces of the same level. In either case, there is a 2 inch (50mm) step that has to be accommodated for either on the interior or exterior of the wall. The step is usually concealed at either the top or the bottom of the upper floor joists. Waste can be minimized by a design that eliminates the need to cut the block.

3.8.2 – Mixing Frame Walls with ICF

In some cases it may be required to switch to conventional framing in a segment of the wall. In such case, all structure above the wood or steel frame should continue as wood or steel. Amvic ICF can be combined with almost all other methods of construction if required.

3.9 – Foundations

3.9.1 – Slab on Grade

ICF can be set either on a strip footing or off a slab. For slab on grade construction, typically the slab is poured first and then the block is started from the slab surface.



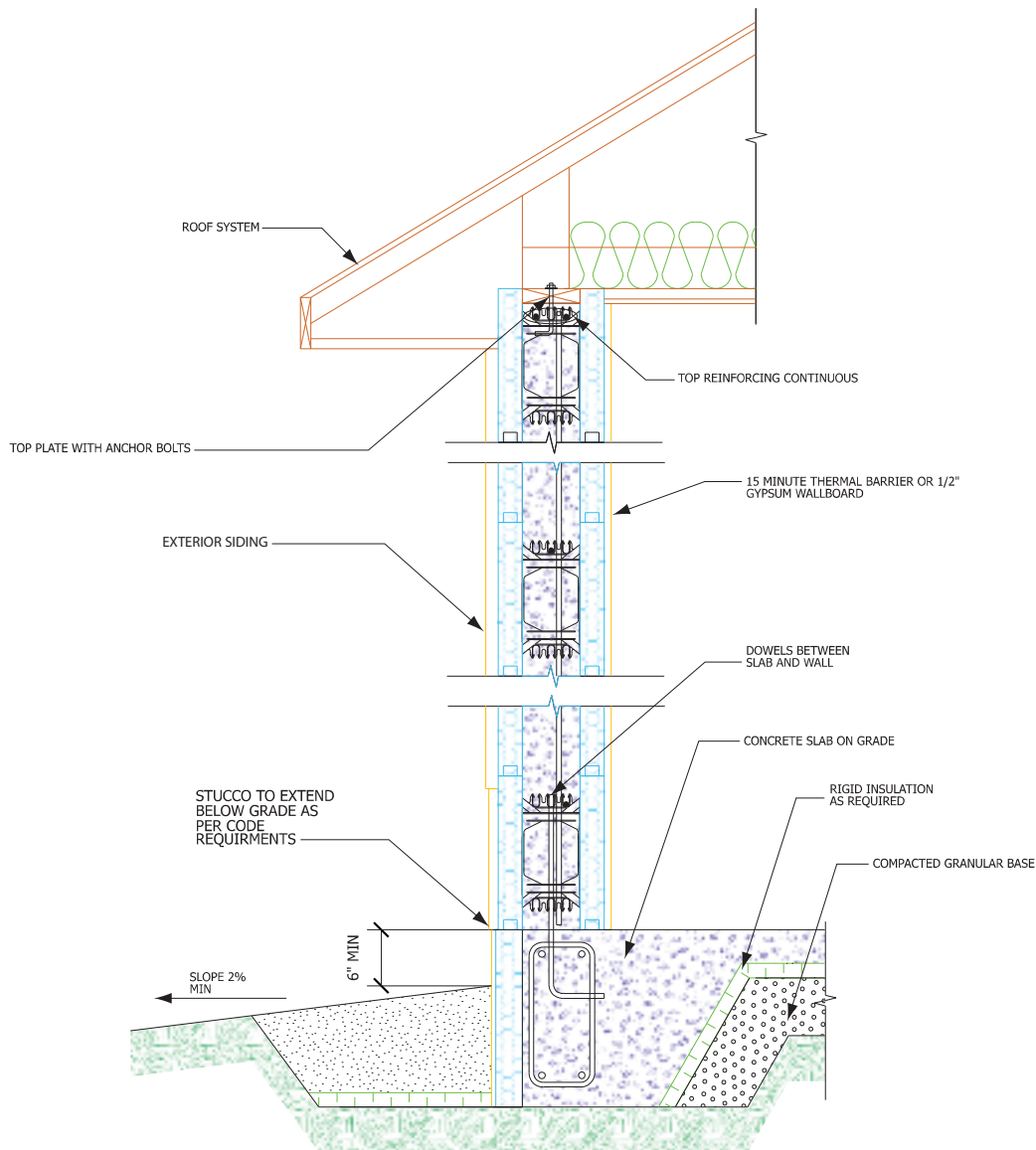

Fig. 3.5 – ICF on slab on grade

An alternative method for installing slab on grade is to first pour the stacked walls off a strip footing before pouring the slab. This method has the advantage of allowing for stamped or stained concrete floors or radiant heating to be installed without creating problems during wall construction. It is also generally faster and costs less.



Tip

Lintels (door/window headers) require special attention and should be designed by a licensed engineer. In addition to top and bottom reinforcing steel, lintels may also require stirrups to resist shear forces. Please refer to Amvic's lintel tables or consult your local licensed engineer for stirrup requirements and the best configuration to facilitate construction and concrete placement.



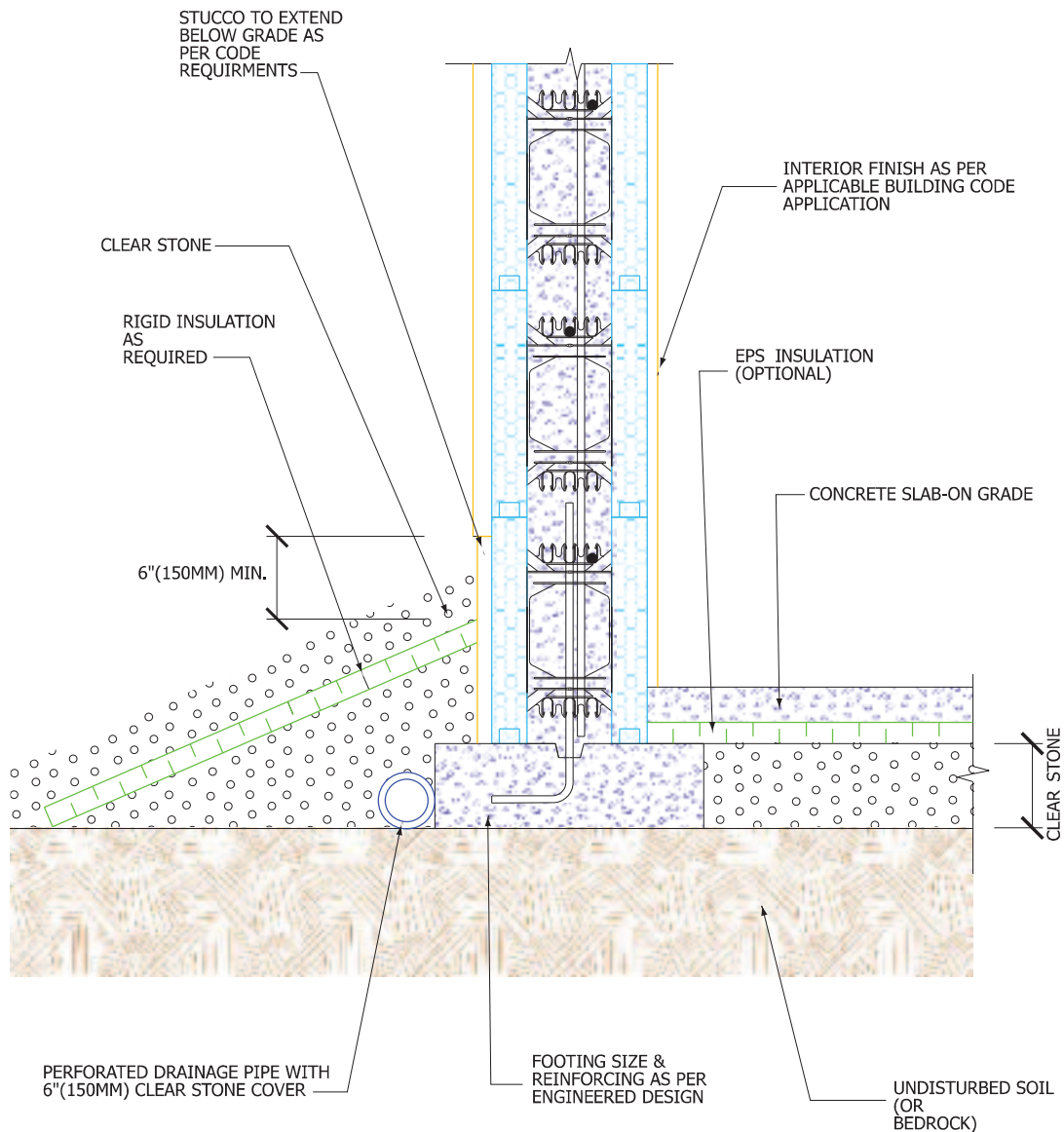

Fig. 3.6 – ICF on strip footing

3.9.2 – Below Grade

Either of the above methods can be used for below grade; however, the alternative method is preferred when the basement floor level is below the water table. In this case, if the waterproofing fails, the cold joint is below the level of the floor and is therefore less prone to water penetration.



3.10 – Windows & Doors

3.10.1 – Window & Door Placement

When selecting the placement of windows and doors, the designer must accommodate for the 11 inch (279mm) wall on the other side of the corner.



Tip

Remember to leave added room for interior trim.



Tip

Doors and windows should be set in at least 16 inches (406mm) from corners as viewed from the exterior.

Hinged doors that are hung on ICF walls should be installed so that the hinge is flush with the inside wall so the door can open 180 degrees without hitting the door jamb. Doors should be specified with jamb extensions and extended thresholds to accommodate the wall thickness and the interior and exterior claddings. Alternatively, a door set with sidelights can be specified and the entire door set to the outside such that the door can swing back against the sidelight, achieving a nearly wide open swing.

3.10.2 – Bucks

Bucks are a framework that holds back the concrete during the pour, providing the opening for installation of doors and windows. They can be either wood or vinyl.

The simplest way to construct wood bucks is to rip cut lumber to the width that corresponds with the block, then assemble the buck before inserting it into the opening.

Vinyl bucks are an excellent alternative to wood bucks. Since they contain no organic materials they provide resistance against water and mold damage and are far more durable over time. Vinyl bucks cost slightly more than wood, approximately \$1-2 per linear foot (0.3-0.6m) of window wrap at current prices.



Tip

Untreated lumber can be used if a moisture barrier is installed between the concrete and the wood.



3.10.3 – Window Mounting

With 11 inch or 13 inch (279 or 330mm) thick walls, windows can be mounted to the exterior as is typical for frame construction, or they can be mounted to the interior with a deep exterior reveal.

If mounted conventionally to the exterior, then the windows are attached to the buck with a nail fin and flashed in with ICF compatible adhesive flashings. In this case, the standard rough opening (RO) should be specified the same as in frame construction.

If the windows are to be recessed either partially or fully to the inside, then this should be detailed in the plans so the bucks can be built to accommodate the recess. The recess can be accommodated either by a second window stop inserted in the buck and the window attached with a nail fin to that, or by using a block style window without a fin.

3.10.4 – Flashing

Appropriate expanded polystyrene (EPS) compatible adhesive backed membrane flashings should be used with ICF such as ProtectoWrap BT20XL.

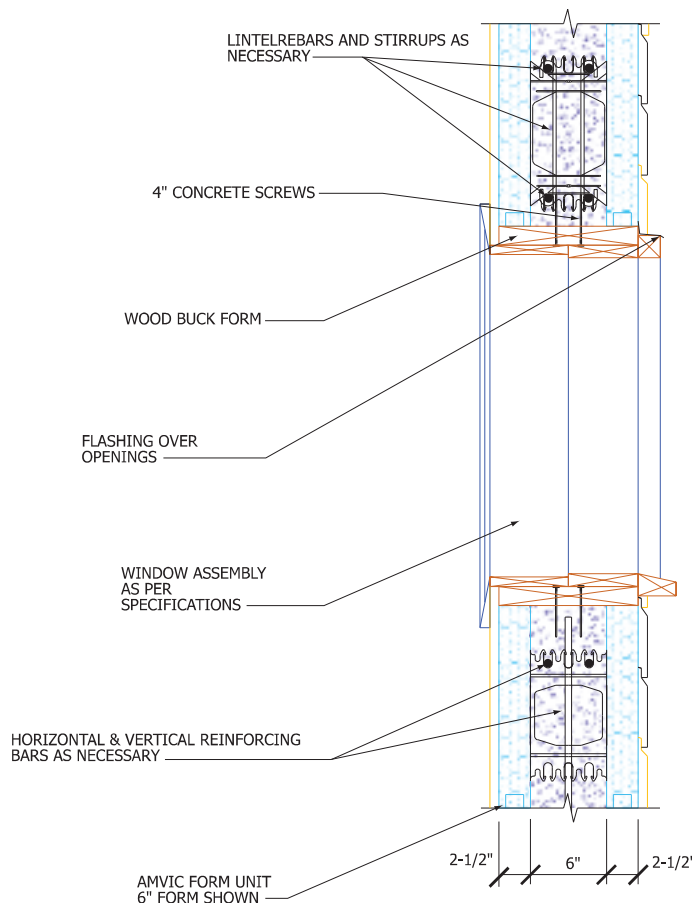

Tip

Adhesion is enhanced by specifying a compatible adhesive water-based primer.

Fig. 3.7 – Typical cross section of a window opening



3.10.5 – Bay Windows

Bay windows can be detailed by any of the following:

- a) Including concrete posts between windows (min 12 inches (304.8mm) between RO's or by engineer's design)
- b) Framing out the bay as a large open rectangle in the concrete with a concrete lintel above either in line with the wall, or following the line of the bay, and then boxing out the bay itself with conventional framing. The advantage of this is that it provides greater structural strength of the structure by providing a continuous concrete band around the top.
- c) Breaking the concrete wall at the bay, then wood framing the entire rest of the structure above the window.
- d) Embedding structural steel posts.

3.10.6 – Top Plates

Top plates are typically either pressure treated or non-treated lumber with a moisture barrier between the concrete and the wood. Top plates are typically 1-1/2 inches (38.1mm) thick, although a few building departments are now requiring a full 3 inches (76.2mm). Most builders desire that the top plate extend the full 11 or 13 inch (279 or 330mm) width of the block. In that way cladding or sheetrock subcontractors have a nailer at the top of the wall. Generally, anchor bolts are wet set during the pour and the plate installed later.

3.11 – Plumbing & Electrical

3.11.1 – Plumbing

Where possible, keep plumbing on interior walls. Plumbing can be run in the exterior walls, but vents and drain lines may have to be installed prior to the pour. Supply lines can easily be run in the block after the pour in the same manner as electric. In bathrooms, it may be most convenient to fur out a wall section rather than embed the plumbing in the ICF.



Tip

Keep plumbing in the slab and route through floor and interior wall cavities to the greatest extent possible.



3.11.2 – Utility Penetrations

Any penetration is easy to accommodate prior to the walls being poured. If there is uncertainty about future potential requirements, a small buck can be installed and filled with foam so that an opening can be made easily later. Exterior lighting, water faucets, dryer vents, service entrances, etc. should be pre-planned.

3.11.3 – Residential Electric

Romex and boxes are installed after the walls are poured and are installed in channels routed within the 2-1/2 inches (63.5mm) of foam covering the concrete.

3.11.4 – Commercial Electric

In commercial construction, where conduit is required, it can be placed within the concrete core as the walls are being assembled. An easier method is to place the conduit in a channel cut into the foam after the walls are poured. In the latter case, metal boxes that have side knockouts should be used.



Fig. 3.8 – Electrical installed in an Amvic ICF wall.





Fig 3.9 – Electrical installed in an Amvic ICF wall.



Important Note

Electrical wiring in the surface of ICF walls may be required to be protected (i.e., metal sheathed or placed in conduit) when installed in routed channels of the foam forms using a "hot knife" (usually available through the manufacturer or your supplying Amvic ICF distributor). Also, electric switch and receptacle boxes will need to be specified to an appropriate depth to fit within the combined 2-1/2 inch (63.5mm) foam layer plus 1/2 to 5/8 inches (12.7 to 15.9mm) interior cladding.

3.12 – Attachments to Walls

Normal cabinetry, shelves, etc. can be securely attached by screwing into the webs. No special provisions are required. Each screw has an allowable capacity of at least 39 lbs withdrawal, 60 lbs lateral. Other items such as curtain rods, towel bars, tissue holders, etc. should be attached to perforated steel backing plates (Grapplers). These plates are pressed into the surface of the foam at locations where fixtures will be installed, prior to the pour. After the pour, sheetrock is installed over the plates and mechanically fastened to the adjacent webs.





Fig 3.10 – Perforated steel backing plate (Grappler).



Fig. 3.11 – Grapplers installed in an ICF wall.



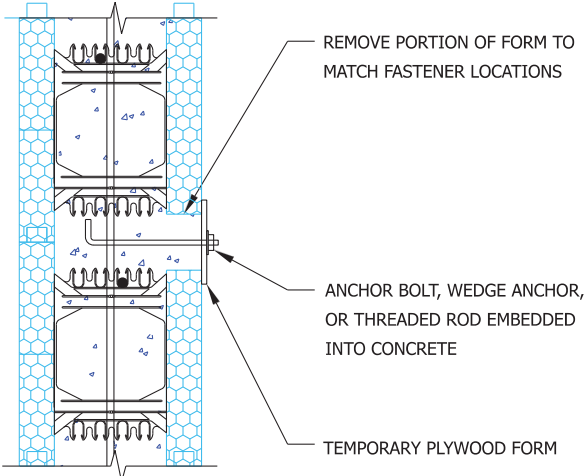

Fig. 3.12 – Hanger detail for heavy loads



3.13 – Floors & Roofs

3.13.1 – Typical Floors

Conventional wood or steel joist supported interior floors are generally hung from ledgers attached to the concrete of the wall with either embedded anchor bolts or with Simpson ICFVL ties. These ledger supported floors can be installed at any vertical elevation on the wall.

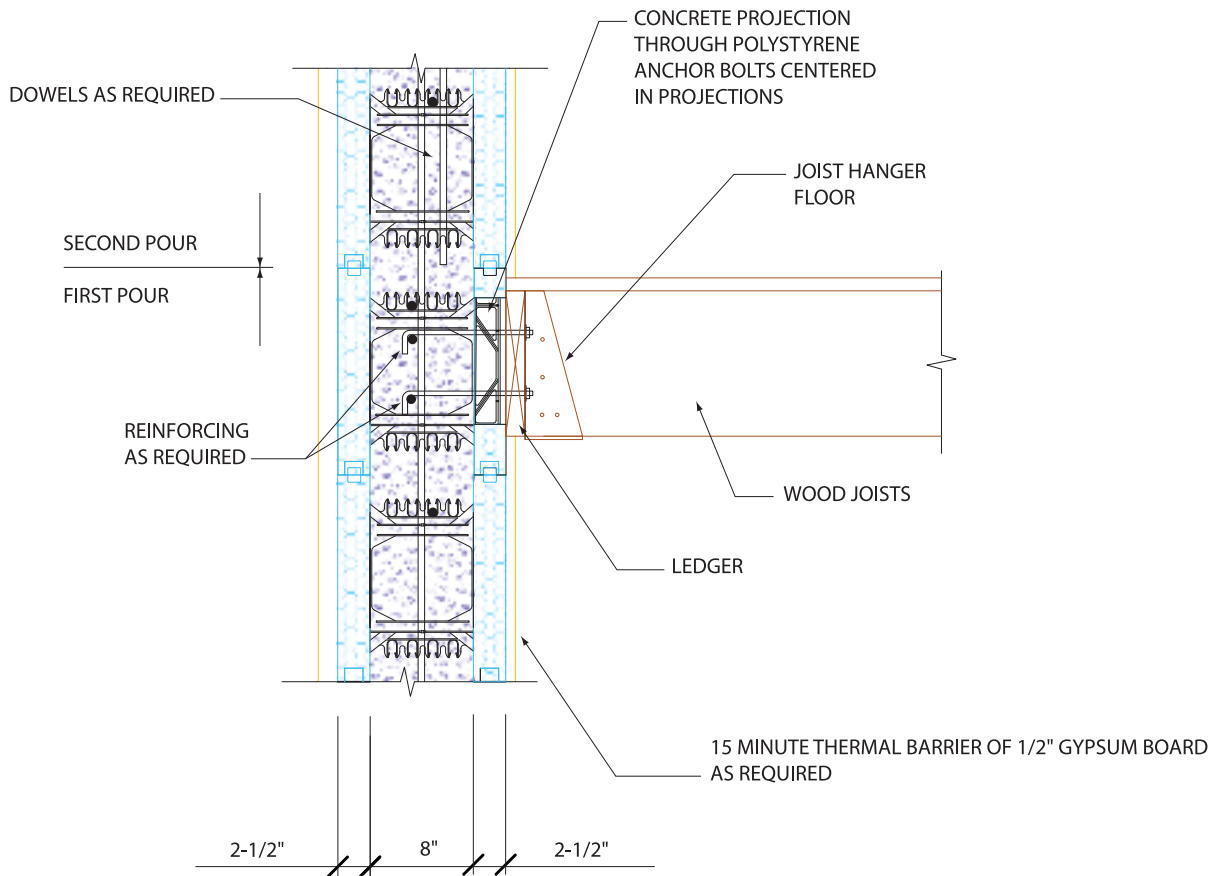

Fig. 3.13 – Typical wood floor joist connection using anchor bolts

3.13.2 – Simpson Strong Tie ICFVL Connectors

Simpson Strong-Tie has developed an ICF ledger connection system that reduces the labor & cost of installing ledgers/rim joists. Use of the Simpson ICFVL-CW eliminates the need for anchor bolts to handle vertical loading.



3.13.3 – Elevated Concrete Floors

Elevated concrete floors can be constructed with ICF poured-in-place methods such as the AmDeck Floor & Roof System™, composite decking, or hollowcore precast. ICF concrete floors like AmDeck provide the best thermal and acoustic separation between floors and can be constructed quickly and easily.

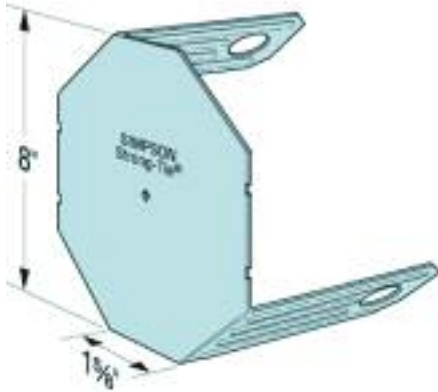

Fig. 3.14 – ICFVL Component made from 14 gauge galvanized steel.

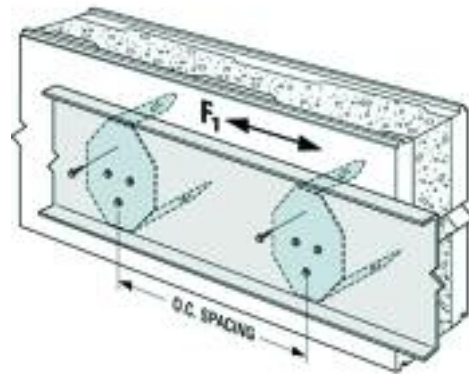

Fig. 3.15 – ICFVL-W or ICFVL-CW Component made from 16 gauge galvanized steel for typical wood ledger installation.

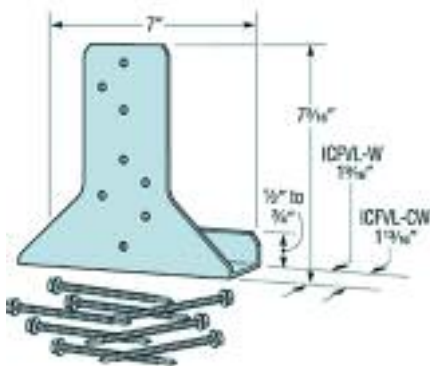

Fig. 3.16 – Installing a steel ledger with ICFVL.



Fig. 3.17 – ICFVL installed on ICF wall.



Fig. 3.18 – Installing a wood ledger with ICFVL.



3.13.4 – Lateral Ties

In some areas of the country, particularly those of high seismic activity, structural engineers will require embedded ties to use the floor diaphragm to transfer loads laterally between walls. The most common connector in use for this purpose is the Simpson PA or similar which is poured in place in the wall and subsequently nailed down into the floor joist through the sheeting. When being installed perpendicular to the floor joist, blocking between the joists is required.

3.13.5 – Rafter/truss Connection

In typical western construction the Simpson H3 connector is used most frequently to connect rafters to the top plate. In high wind zones, embedded hurricane ties that wrap the rafters are poured in place.

3.14 – Special Applications

3.14.1 – Projections and Cantilevers

Projections and cantilevers require special attention. The most straightforward approach is to support upper storey concrete walls by placing them directly above a corresponding concrete wall below. Otherwise, detailed structural engineering and steel beams will be required. Upper story concrete walls cannot be supported either by wood frame or light gauge steel frames, however when using concrete flooring systems, cantilevering modest distances becomes more feasible without substantial added costs.

3.14.2 – Gables

Gables of virtually any pitch may be constructed with ICF. If there is a cathedral ceiling in the interior space, completing the gable with ICF is the recommended solution. Alternatively, the ICF wall can be stopped at the plate line and the gable can then be framed conventionally.

3.14.3 – Columns

When forming columns of concrete, adequate space is needed to install rebar and properly place and vibrate the concrete.



Rule of Thumb

The space between any two openings (door jambs or windows) should not be less than 18 inches (457mm).



3.14.4 – Garages

There are very little cost savings gained from switching from ICF to frame construction for an attached garage. When adding an ICF garage, the wall between the house and the garage is conventionally framed and the wall, of where the garage door will be located, requires very few forms. As a result, the amount of additional block required for a 2-3 car garage is approximately only 1-1.5 walls.

The benefits of doing an ICF garage include, improved fire protection, energy savings, added comfort, and a uniform substrate for exterior cladding. Often total construction time is also reduced by several days since there will be no need to frame the garage after the house has been constructed.

3.15 – Concrete Specification

The project engineer will typically specify the concrete mix requirements (specifically the design strength of the concrete), the slump and the aggregate size. Amvic generally recommends a slump of 5 to 6 inches (125 to 150mm) and a 1/2-3/4 inch (13-19mm) aggregate size, depending on the block size.

3.15.1 – Engineering Inspection

When 3000 psi concrete is specified for use with Amvic ICF, a special inspection of the concrete pour by a qualified engineer is usually required.

3.16 – Steel Reinforcement for Walls

3.16.1 – Overview

Building any structure using Amvic ICFs requires the installer to have a good knowledge of the fundamentals of steel reinforcement. This part of the manual will discuss the basics of reinforcing steel requirements for Amvic ICF walls.

3.16.2 – Plan Requirements

The designer (Architect/Engineer) of any project should clearly indicate the following information on his plans:

1. Separate cross-sections of all walls using Amvic ICF. Each cross section should clearly show the size of Amvic ICF block used [i.e. 4, 6, 8, or 10 inch (100, 150, 203 or 254mm)] for the building inspector and installer.



2. Each cross-section should show the wall heights involved for every storey.
3. Vertical and horizontal reinforcing steel bar sizes, spacing and grade of steel should be clearly marked for every storey in each wall cross-section or in a separate note on other sheets.
4. The placement of reinforcing steel, especially vertical should be clearly marked (i.e. off center or towards interior/exterior or centered in the wall).
5. The designer should specify the lap splice type and lengths for every section of the wall where splicing is anticipated. (Please refer to Reinforcing Steel Splicing in **section 6.6** of this chapter.)

3.16.3 – Horizontal Reinforcement

Amvic polypropylene webs are specifically designed to accommodate and secure the horizontal reinforcing steel in place without the need to tie them.

Typically the first course of horizontal reinforcement is placed in the notches closer to the EPS panel.

The second course of horizontal reinforcement is placed in the notch towards the center of the concrete wall. The third course is placed in the same position as the first course. The fourth course is placed in the same position as the second.

This staggered pattern of horizontal reinforcement is necessary to allow for the vertical reinforcement to be placed from the top and weave in between the horizontal steel bars.

Figures 3.19 and 3.20 below show typical vertical and horizontal reinforcing patterns for below grade and above grade applications using 8 inch (203mm) Amvic ICF block respectively.

3.16.4 – Vertical Reinforcement

Vertical reinforcement is placed after the forms have been stacked to full height. In case of a multi-storey wall, the vertical reinforcement is placed after the erection of each individual storey. Vertical reinforcement bars are placed from the top between the horizontal reinforcement and secured according to the project plans and specs.

Refer to figures 3.19 and 3.20 below.



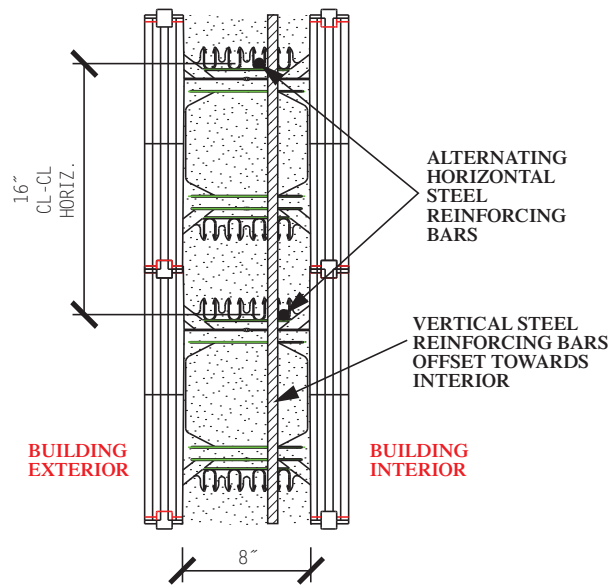

Figure 3.19 – Typical below grade reinforcing steel placement

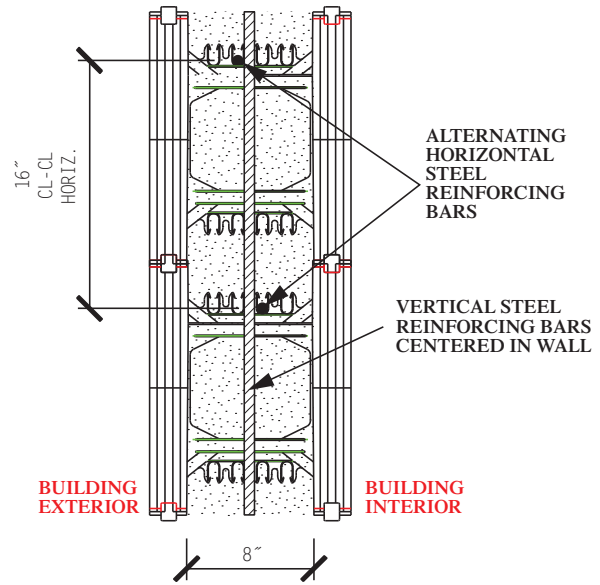

Figure 3.20 – Typical above grade reinforcing steel placement

3.16.5 - Reinforcement for Wall Openings

Most walls will have window or door openings or both. Creating a wall opening in a reinforced concrete wall creates extra stress around that opening especially at the corners. Window and door headers also known as lintels can be subjected to significant bending movement and shear forces depending on several factors.

Please refer to Appendix A for more details on how to handle reinforcement in wall openings.

3.16.6 – Reinforcement Splicing

Steel reinforcement typically comes in 20 foot (6 meter) lengths. In such cases where steel reinforcement is required to exceed this length, then a splice is required. The main purpose of the splice is to transform the stresses, whether tensile or compression, from one steel reinforcing bar, or a group of bundled bars, to another in order to satisfy the governing local building/engineering codes and/or requirements of engineering plans and specs.

3.16.6.1 – Types of Lap Splice

For the purpose and scope of this manual we will only discuss one type of splicing known as **lap splicing**.



Lap splicing means overlapping reinforcing steel over a certain length. The length of the splice should be calculated according to the local building codes or by a local engineer and specified on the project plans.

There are two main types of lap splices:

1. **Contact Lap Splice** – The lapped reinforcing bars **MUST** be in contact with each other and secured together.

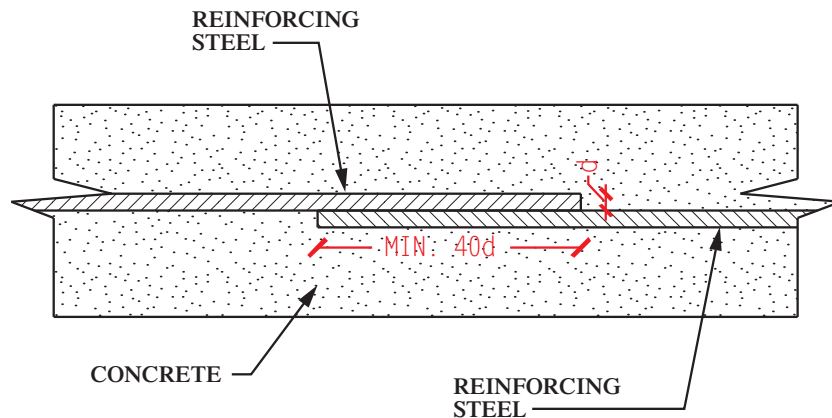

Figure 3.21 – Contact lap splice

2. **Non-Contact Lap Splice** – The reinforcing bars are allowed to be spaced at a distance of one fifth ($1/5$) of the lapped length to a maximum of 6 inches or 150 mm.

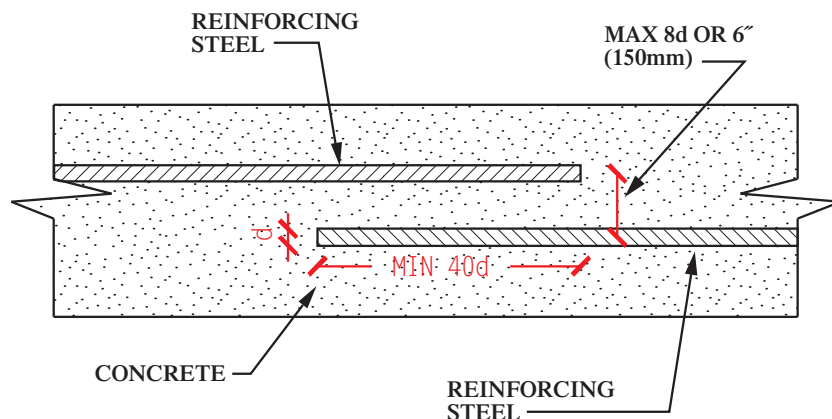

Figure 3.22 – Non-contact lap splice



3.16.7 – Minimum Requirement for Lap Splice Length

Both types of lap splices have a minimum splice length requirement as follows:



Tip

Minimum Lap Splice Length = 40 x Reinforcing Steel bar diameter (40d)



Example

Canadian Reinforcing Steel System

When splicing a 10M reinforcing steel bar which has a diameter of 11.3mm, the minimum lapped splice length is:

$$40 \times 11.3\text{mm} = 452\text{mm}$$



Example

US Reinforcing Steel System

When splicing a #5 reinforcing steel bar which has a diameter of 0.625 inches, the minimum lapped splice length is:

$$40 \times 0.625 \text{ inches} = 25 \text{ inches}$$



3.17 – Lapped Splices for Multiple Concrete Pours

When a project has more than one storey of Amvic ICF walls, it is necessary for the installer to understand how to perform vertical reinforcement lap splices between the different pours.

There are two options, both of which are satisfactory from an engineering/structural standpoint.

Option 1

Extend the vertical reinforcement steel bars beyond the top level of the lower storey. The length of the extension should be equal to the required splice length specified by the design engineer or a minimum length of $40d$ (where d = diameter of smaller steel bar being spliced). Please refer to figure 3.23 below for typical details.

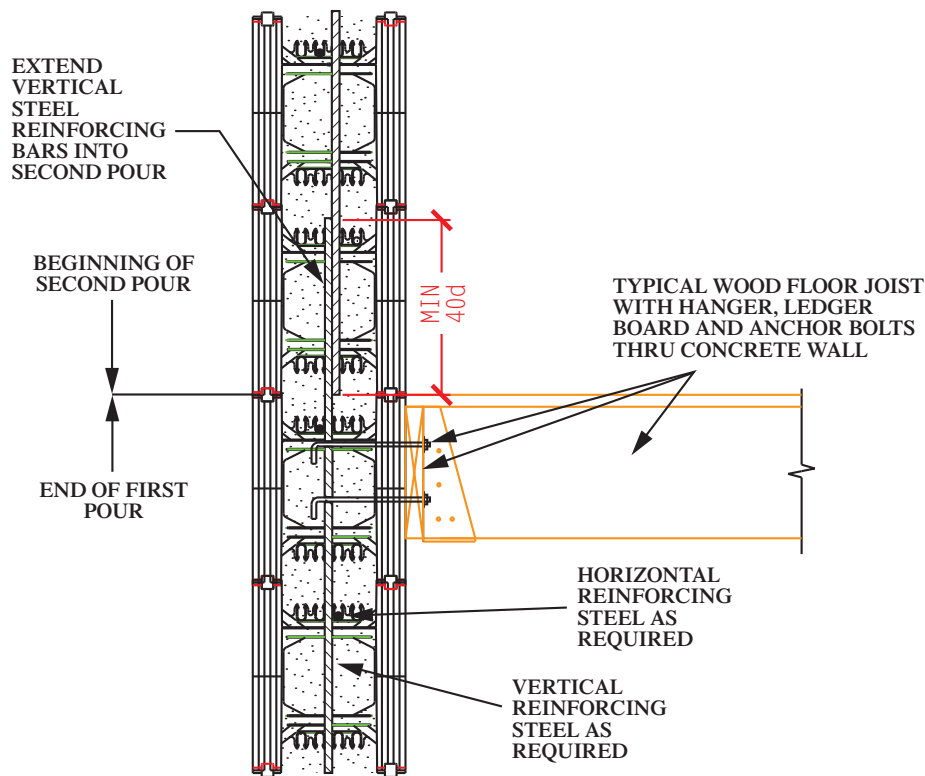

Figure 3.23 – Vertical lap splice



Option 2

Cut the vertical reinforcement steel bars for the lower storey so that they are flush with the top of that wall. Shortly after pouring the concrete, wet-set additional vertical reinforcing bars also known as dowels into the concrete. These should extend into the freshly poured wall a length equal to the splice length specified by the design engineer or a minimum length of $40d$ (where d = diameter of smaller steel bar being spliced). The wet-set vertical splice reinforcing steel bars should ALSO protrude into the upper wall by the same splice length specified by the design engineer or $40d$ as a minimum. Please refer to figure 3.24 below for details.

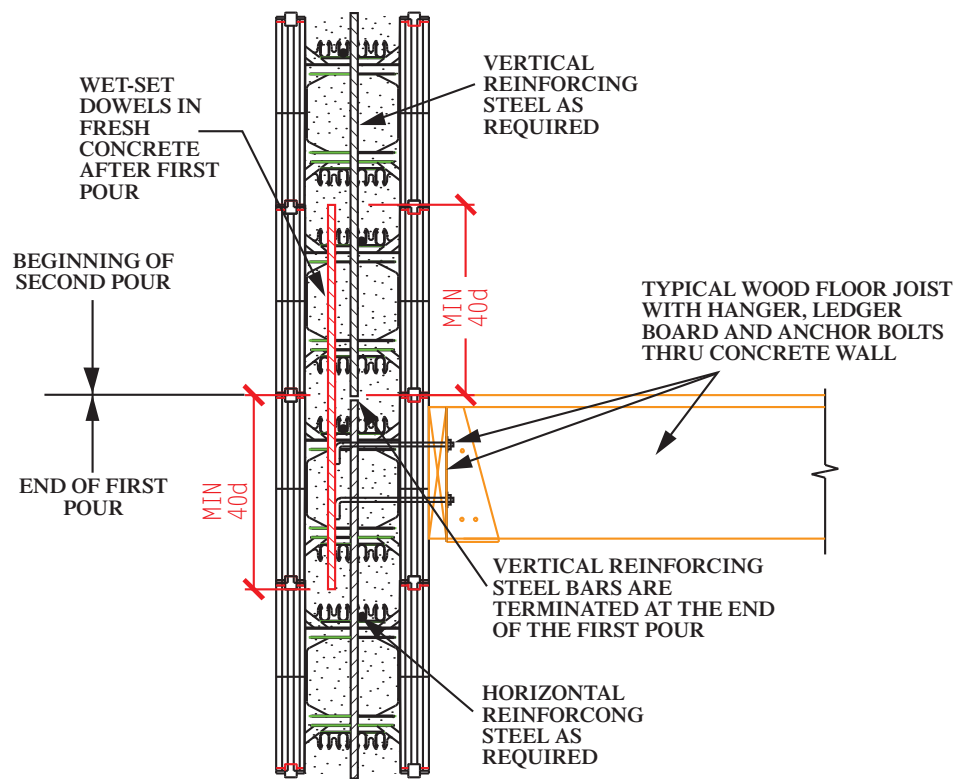

Figure 3.24 – Vertical lap splice using a dowel

3.18 – Designing Reinforcing Steel for Walls

Determining the reinforcing steel schedule whether vertical or horizontal is a structural engineering task which depends on many factors. This is beyond the scope of this technical manual; however, some tools are available for the residential construction market to assist in reinforcing steel design. The tools are explained below.



3.18.1 – Canada

CCMC report no.13043-R contains reinforcing steel tables for below grade and up to 2 storeys of above grade applications in residential projects. The report also contains some lintel tables for wall openings both in metric and imperial units.

There are applicability limits mentioned in the report which must be adhered to.

If the particular project at hand falls outside of these limits then a local licensed/registered engineer should be retained.



Code Requirements (CAN)

- A – Design of reinforced concrete shall be in accordance with CSA A23.3.*
- B – Reinforcing steel placement shall conform to CSA A23.1, CSA A23.4 and/or the local building code having jurisdiction.*
- C – Reinforcing steel bars shall conform to clause 7 of CSA A23.1 AND CSA G30.18.*
- D – Minimum Steel Yield Strength shall not be less than 300 MPA (40 ksi).*

3.18.2 – United States

NAHB (National Association of Home Builders) in association with PCA (Portland Cement Association) have prepared the “**Prescriptive Method for Insulating Concrete Forms in Residential Construction**” specifically for the ICF industry [REF. 1].

This document contains reinforcing steel schedules for below grade and up to 2 storeys above grade applications. It also contains several lintel tables for wall openings in different applications. As expected, there are limitations which must be adhered to.



Code Requirements (USA)

- A – Design of reinforced concrete and placement of reinforcing steel bars shall be in accordance to ACI 318 or ACI 332 and/or the local building code having jurisdiction.*
- B – Reinforcing steel bars shall conform to one of the following specifications;*
 - 1 – ASTM A615 – Specifications for Deformed and Plain Billet-Steel Bars*
 - B – 2 – ASTM A706 – Specifications for Low-Alloy Steel Deformed and Plain Bars*
 - B – 3 – ASTM A996 – Specifications for Rail-Steel and Axle Steel Deformed Bars*
- C – Minimum yield strength of reinforcing steel shall be Grade 40 (300 MPa) except for seismic design categories D1 & D2 the minimum yield strength of reinforcing steel shall be Grade 60 (400 MPa).*



PCA (Portland Cement Association) has prepared another tool for engineers to assist in the design of ICF walls – “Structural Design of Insulating Concrete Form Walls in Residential Construction” [REF. 2]. This publication explains in more detail the engineering principles involved in design load bearing and non-load bearing ICF walls even for walls outside the scope of “The Prescriptive Method”.



Important Note

For applications that fall outside the scope of the “Prescriptive Method” a local licensed/registered engineer should be retained.

3.19 – Steel Reinforcing Bars and Jobsite Safety

Unguarded protruding steel reinforcing bars are hazardous and can result in injury or death.

The following measures greatly reduce the hazards of exposed reinforcing steel:

- Guard all protruding ends of reinforcing steel bars with caps or wooden troughs, or
- Bend reinforcing steel so exposed ends are no longer upright.
- When employees are working at any height above exposed rebar, fall protection/ prevention is the first line of defense against impalement.



Figure 3.25 – Plastic mushroom caps on protruding steel bars





Code Compliance

According to OSHA (Occupational Safety & Health Administration – USA) article 1926.701 (b), the following clause shall apply to the jobsite:

“All protruding reinforcing steel, onto and into which employees could fall, shall be guarded to eliminate the hazard of impalement.”

A similar compliance clause present in OSHA (Occupational Health and Safety Act – Canada).



3.20 – Preferred Coursing & Corner Dimensions

Table 3.1 - Vertical Course Chart for 4, 6 & 8 inch Amvic Blocks

No. of Courses	Total Height (Inch)	Total Height (ft - inch)	Plus 2 inch Height Adjuster (Inch)	Plus 3 inch Height Adjuster (Inch)	Plus 4 inch Height Adjuster (Inch)
1	16"	1' 4"	18"	19"	20"
2	32"	2' 8"	34"	35"	36"
3	48"	4' 0"	50"	51"	52"
4	64"	5' 4"	66"	67"	68"
5	80"	6' 8"	82"	83"	84"
6	96"	8' 0"	98"	99"	100"
7	112"	9' 4"	114"	115"	116"
8	128"	10' 8"	130"	131"	132"
9	144"	12' 0"	146"	147"	148"
10	160"	13' 4"	162"	163"	164"
11	176"	14' 8"	178"	179"	180"
12	192"	16' 0"	194"	195"	196"
13	208"	17' 4"	210"	211"	212"
14	224"	18' 8"	226"	227"	228"
15	240"	20' 0"	242"	243"	244"
16	256"	21' 4"	258"	259"	260"
17	272"	22' 8"	274"	275"	276"
18	288"	24' 0"	300"	301"	302"
19	304"	25' 4"	306"	307"	308"
20	320"	26' 8"	322"	323"	324"

Table 3.2 - Vertical Course Chart for 10 inch Amvic Blocks

No. of Courses	Total Height (Inch)	Total Height (ft - inch)	Plus 2 inch Height Adjuster (Inch)	Plus 3 inch Height Adjuster (Inch)	Plus 4 inch Height Adjuster (Inch)
1	24"	2' 0"	26"	27"	28"
2	48"	4' 0"	50"	51"	52"
3	72"	6' 0"	74"	75"	76"
4	96"	8' 0"	98"	99"	100"
5	120"	10' 0"	122"	123"	124"
6	144"	12' 0"	146"	147"	148"
7	168"	14' 0"	170"	171"	172"
8	192"	16' 0"	194"	195"	196"
9	216"	18' 0"	218"	219"	220"
10	240"	20' 0"	242"	243"	244"
11	264"	22' 0"	266"	267"	268"
12	288"	24' 0"	290"	291"	292"
13	312"	26' 0"	314"	315"	316"
14	336"	28' 0"	338"	339"	340"
15	360"	30' 0"	362"	363"	364"
16	384"	32' 0"	386"	387"	388"
17	408"	34' 0"	410"	411"	412"
18	432"	36' 0"	434"	435"	436"
19	456"	38' 0"	458"	459"	460"
20	480"	40' 0"	482"	483"	484"



Table 3.3 - Preferred 90° Corner Dimensions for 4 inch Amvic Block⁽³⁾

Inside - Outside Corner Dimension (ft - in)	Outside - Outside Corner Dimension (ft - in)	Inside - Inside Corner Dimension (ft - in)	Inside - Outside Corner Dimension (ft - in)	Outside - Outside Corner Dimension (ft - in)	Inside - Inside Corner Dimension (ft - in)
1' 4" (1)	2' 1" (1)	7" (1)	13' 4"	14' 1"	12' 7"
1' 10" (1)	2' 7" (1)	1' 1" (1)	13' 10"	14' 7"	13' 1"
2' 4" (2)	3' 1" (2)	1' 7" (2)	14' 4"	15' 1"	13' 7"
2' 10"	3' 7"	2' 1"	14' 10"	15' 7"	14' 1"
3' 4"	4' 1"	2' 7"	15' 4"	16' 1"	14' 7"
3' 10"	4' 7"	3' 1"	15' 10"	16' 7"	15' 1"
4' 4"	5' 1"	3' 7"	16' 4"	17' 1"	15' 7"
4' 10"	5' 7"	4' 1"	16' 10"	17' 7"	16' 1"
5' 4"	6' 1"	4' 7"	17' 4"	18' 1"	16' 7"
5' 10"	6' 7"	5' 1"	17' 10"	18' 7"	17' 1"
6' 4"	7' 1"	5' 7"	18' 4"	19' 1"	17' 7"
6' 10"	7' 7"	6' 1"	18' 10"	19' 7"	18' 1"
7' 4"	8' 1"	6' 7"	19' 4"	20' 1"	18' 7"
7' 10"	8' 7"	7' 1"	19' 10"	20' 7"	19' 1"
8' 4"	9' 1"	7' 7"	20' 4"	21' 1"	19' 7"
8' 10"	9' 7"	8' 1"	20' 10"	21' 7"	20' 1"
9' 4"	10' 1"	8' 7"	21' 4"	22' 1"	20' 7"
9' 10"	10' 7"	9' 1"	21' 10"	22' 7"	21' 1"
10' 4"	11' 1"	9' 7"	22' 4"	23' 1"	21' 7"
10' 10"	11' 7"	10' 1"	22' 10"	23' 7"	22' 1"
11' 4"	12' 1"	10' 7"	23' 4"	24' 1"	22' 7"
11' 10"	12' 7"	11' 1"	23' 10"	24' 7"	23' 1"
12' 4"	13' 1"	11' 7"	24' 4"	25' 1"	23' 7"
12' 10"	13' 7"	12' 1"	24' 10"	25' 7"	24' 1"

(1) Minimum dimension required for a short corner with a stack joint

(2) Minimum dimension required for a short corner with a running bond pattern

(3) Red dimensions indicate use of full size Amvic blocks and no cutting required

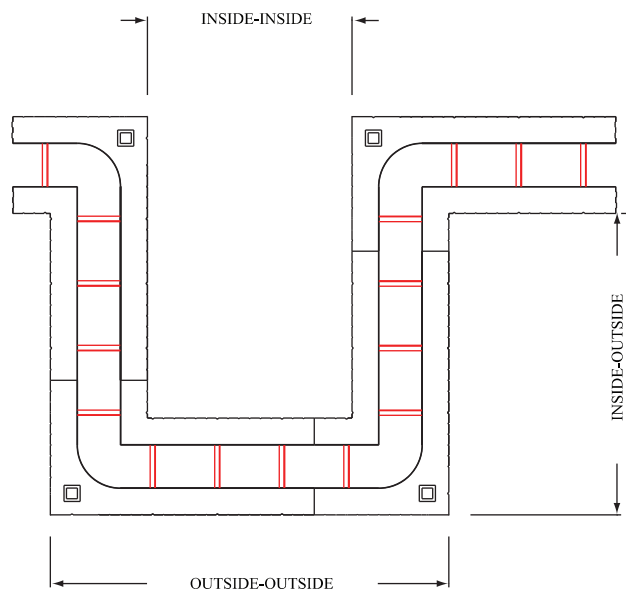

Table 3.4 - Preferred 90° Corner Dimensions for 6 inch Amvic Block⁽³⁾

Inside - Outside Corner Dimension (ft - in)	Outside - Outside Corner Dimension (ft - in)	Inside - Inside Corner Dimension (ft - in)	Inside - Outside Corner Dimension (ft - in)	Outside - Outside Corner Dimension (ft - in)	Inside - Inside Corner Dimension (ft - in)
1' 6" (1)	2' 5" (1)	0' 7" (1)	13' 6"	14' 5"	12' 7"
2' 0" (1)	2' 11" (1)	1' 1" (1)	14' 0"	14' 11"	13' 1"
2' 6" (2)	3' 5" (2)	1' 7" (2)	14' 6"	15' 5"	13' 7"
3' 0"	3' 11"	2' 1"	15' 0"	15' 11"	14' 1"
3' 6"	4' 5"	2' 7"	15' 6"	16' 5"	14' 7"
4' 0"	4' 11"	3' 1"	16' 0"	16' 11"	15' 1"
4' 6"	5' 5"	3' 7"	16' 6"	17' 5"	15' 7"
5' 0"	5' 11"	4' 1"	17' 0"	17' 11"	16' 1"
5' 6"	6' 5"	4' 7"	17' 6"	18' 5"	16' 7"
6' 0"	6' 11"	5' 1"	18' 0"	18' 11"	17' 1"
6' 6"	7' 5"	5' 7"	18' 6"	19' 5"	17' 7"
7' 0"	7' 11"	6' 1"	19' 0"	19' 11"	18' 1"
7' 6"	8' 5"	6' 7"	19' 6"	20' 5"	18' 7"
8' 0"	8' 11"	7' 1"	20' 0"	20' 11"	19' 1"
8' 6"	9' 5"	7' 7"	20' 6"	21' 5"	19' 7"
9' 0"	9' 11"	8' 1"	21' 0"	21' 11"	20' 1"
9' 6"	10' 5"	8' 7"	21' 6"	22' 5"	20' 7"
10' 0"	10' 11"	9' 1"	22' 0"	22' 11"	21' 1"
10' 6"	11' 5"	9' 7"	22' 6"	23' 5"	21' 7"
11' 0"	11' 11"	10' 1"	23' 0"	23' 11"	22' 1"
11' 6"	12' 5"	10' 7"	23' 6"	24' 5"	22' 7"
12' 0"	12' 11"	11' 1"	24' 0"	24' 11"	23' 1"
12' 6"	13' 5"	11' 7"	24' 6"	25' 5"	23' 7"
13' 0"	13' 11"	12' 1"	25' 0"	25' 11"	24' 1"

(1) Minimum dimension required for a short corner with a stack joint

(2) Minimum dimension required for a short corner with a running bond pattern

(3) Red dimensions indicate use of full size Amvic blocks and no cutting required

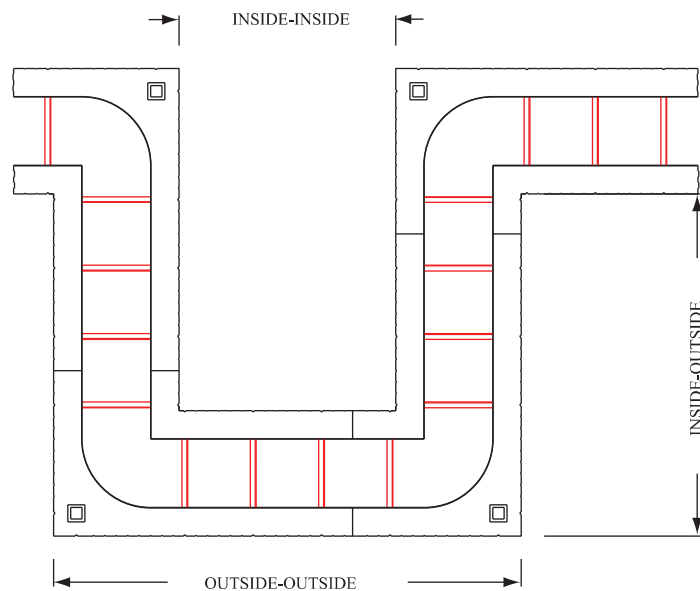

Table 3.5 - Preferred 90° Corner Dimensions for 8 inch Amvic Block⁽³⁾

Inside - Outside Corner Dimension (ft - in)	Outside - Outside Corner Dimension (ft - in)	Inside - Inside Corner Dimension (ft - in)	Inside - Outside Corner Dimension (ft - in)	Outside - Outside Corner Dimension (ft - in)	Inside - Inside Corner Dimension (ft - in)
1' 8" ⁽¹⁾	2' 9" ⁽¹⁾	0' 7" ⁽¹⁾	13' 8"	14' 9"	12' 7"
2' 2" ⁽¹⁾	3' 3" ⁽¹⁾	1' 1" ⁽¹⁾	14' 2"	15' 3"	13' 1"
2' 8" ⁽²⁾	3' 9" ⁽²⁾	1' 7" ⁽²⁾	14' 8"	15' 9"	13' 7"
3' 2"	4' 3"	2' 1"	15' 2"	16' 3"	14' 1"
3' 8"	4' 9"	2' 7"	15' 8"	16' 9"	14' 7"
4' 2"	5' 3"	3' 1"	16' 2"	17' 3"	15' 1"
4' 8"	5' 9"	3' 7"	16' 8"	17' 9"	15' 7"
5' 2"	6' 3"	4' 1"	17' 2"	18' 3"	16' 1"
5' 8"	6' 9"	4' 7"	17' 8"	18' 9"	16' 7"
6' 2"	7' 3"	5' 1"	18' 2"	19' 3"	17' 1"
6' 8"	7' 9"	5' 7"	18' 8"	19' 9"	17' 7"
7' 2"	8' 3"	6' 1"	19' 2"	20' 3"	18' 1"
7' 8"	8' 9"	6' 7"	19' 8"	20' 9"	18' 7"
8' 2"	9' 3"	7' 1"	20' 2"	21' 3"	19' 1"
8' 8"	9' 9"	7' 7"	20' 8"	21' 9"	19' 7"
9' 2"	10' 3"	8' 1"	21' 2"	22' 3"	20' 1"
9' 8"	10' 9"	8' 7"	21' 8"	22' 9"	20' 7"
10' 2"	11' 3"	9' 1"	22' 2"	23' 3"	21' 1"
10' 8"	11' 9"	9' 7"	22' 8"	23' 9"	21' 7"
11' 2"	12' 3"	10' 1"	23' 2"	24' 3"	22' 1"
11' 8"	12' 9"	10' 7"	23' 8"	24' 9"	22' 7"
12' 2"	13' 3"	11' 1"	24' 2"	25' 3"	23' 1"
12' 8"	13' 9"	11' 7"	24' 8"	25' 9"	23' 7"
13' 2"	14' 3"	12' 1"	25' 2"	26' 3"	24' 1"

(1) Minimum dimension required for a short corner with a stack joint

(2) Minimum dimension required for a short corner with a running bond pattern

(3) Red dimensions indicate use of full size Amvic blocks and no cutting required

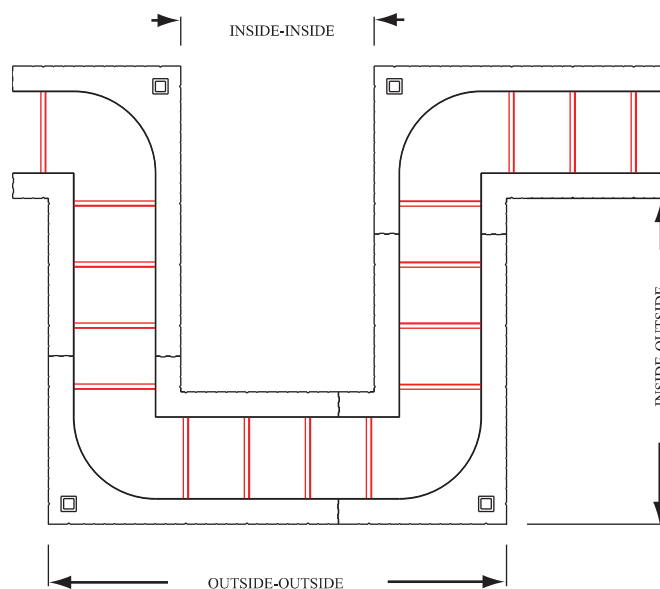

Table 3.6 - Preferred 90° Corner Dimensions for 10 inch Amvic Block⁽³⁾

Inside - Outside Corner Dimension (ft - in)	Outside - Outside Corner Dimension (ft - in)	Inside - Inside Corner Dimension (ft - in)	Inside - Outside Corner Dimension (ft - in)	Outside - Outside Corner Dimension (ft - in)	Inside - Inside Corner Dimension (ft - in)
1' 10" ⁽¹⁾	3' 1" ⁽¹⁾	0' 7" ⁽¹⁾	13' 10"	15' 1"	12' 7"
2' 4" ⁽¹⁾	3' 7" ⁽¹⁾	1' 1" ⁽¹⁾	14' 4"	15' 7"	13' 1"
2' 10" ⁽¹⁾	4' 1" ⁽¹⁾	1' 7" ⁽¹⁾	14' 10"	16' 1"	13' 7"
3' 4" ⁽¹⁾	4' 7" ⁽¹⁾	2' 1" ⁽¹⁾	15' 4"	16' 7"	14' 1"
3' 10" ⁽²⁾	5' 1" ⁽²⁾	2' 7" ⁽²⁾	15' 10"	17' 1"	14' 7"
4' 4"	5' 7"	3' 1"	16' 4"	17' 7"	15' 1"
4' 10"	6' 1"	3' 7"	16' 10"	18' 1"	15' 7"
5' 4"	6' 7"	4' 1"	17' 4"	18' 7"	16' 1"
5' 10"	7' 1"	4' 7"	17' 10"	19' 1"	16' 7"
6' 4"	7' 7"	5' 1"	18' 4"	19' 7"	17' 1"
6' 10"	8' 1"	5' 7"	18' 10"	20' 1"	17' 7"
7' 4"	8' 7"	6' 1"	19' 4"	20' 7"	18' 1"
7' 10"	9' 1"	6' 7"	19' 10"	21' 1"	18' 7"
8' 4"	9' 7"	7' 1"	20' 4"	21' 7"	19' 1"
8' 10"	10' 1"	7' 7"	20' 10"	22' 1"	19' 7"
9' 4"	10' 7"	8' 1"	21' 4"	22' 7"	20' 1"
9' 10"	11' 1"	8' 7"	21' 10"	23' 1"	20' 7"
10' 4"	11' 7"	9' 1"	22' 4"	23' 7"	21' 1"
10' 10"	12' 1"	9' 7"	22' 10"	24' 1"	21' 7"
11' 4"	12' 7"	10' 1"	23' 4"	24' 7"	22' 1"
11' 10"	13' 1"	10' 7"	23' 10"	25' 1"	22' 7"
12' 4"	13' 7"	11' 1"	24' 4"	25' 7"	23' 1"
12' 10"	14' 1"	11' 7"	24' 10"	26' 1"	23' 7"
13' 4"	14' 7"	12' 1"	25' 4"	26' 7"	24' 1"

(1) Minimum dimension required for a short corner with a stack joint

(2) Minimum dimension required for a short corner with a running bond pattern

(3) Red dimensions indicate use of full size Amvic blocks and no cutting required

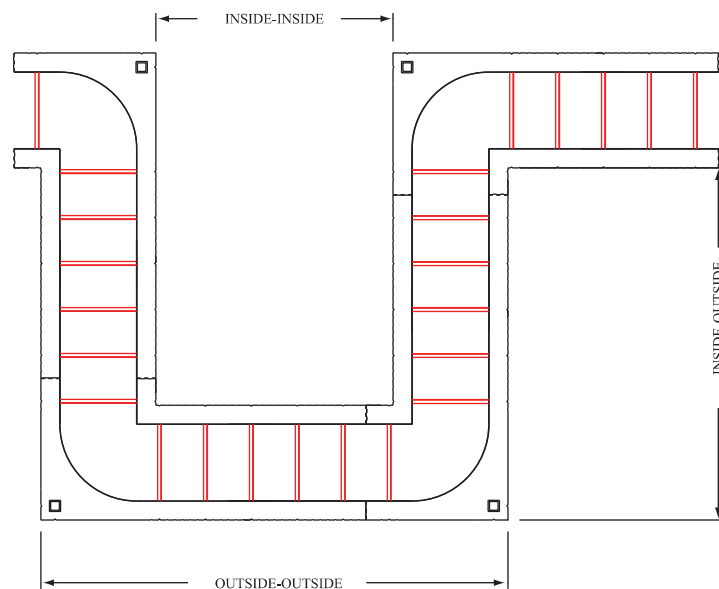

Table 3.7 - Preferred 45° Corner Dimensions for 4 inch Amvic Block⁽³⁾

Bay Projection Dimension C (ft - in)	Outside - Outside Bay Dimension A (ft - in)	Inside - Inside Bay Dimension B (ft - in)
10 1/16" (1)	1' 6" (1)	10 9/16" (1)
1' 2 5/16" (1)	2' 0" (1)	1' 4 9/16" (1)
1' 6 9/16" (2)	2' 6" (2)	1' 10 9/16" (2)
1' 10 13/16"	3' 0"	2' 4 9/16"
2' 3 1/16"	3' 6"	2' 10 9/16"
2' 7 5/16"	4' 0"	3' 4 9/16"
2' 11 9/16"	4' 6"	3' 10 9/16"
3' 3 13/16"	5' 0"	4' 4 9/16"
3' 8 1/16"	5' 6"	4' 10 9/16"
4' 5/16"	6' 0"	5' 4 9/16"
4' 4 9/16"	6' 6"	5' 10 9/16"
4' 8 13/16"	7' 0"	6' 4 9/16"
5' 1 1/16"	7' 6"	6' 10 9/16"
5' 5 5/16"	8' 0"	7' 4 9/16"
5' 9 9/16"	8' 6"	7' 10 9/16"
6' 1 13/16"	9' 0"	8' 4 9/16"

- (1) Minimum dimension required for a short corner with a stack joint
- (2) Minimum dimension required for a short corner with a running bond pattern
- (3) Red dimensions indicate use of full size Amvic blocks and no cutting required

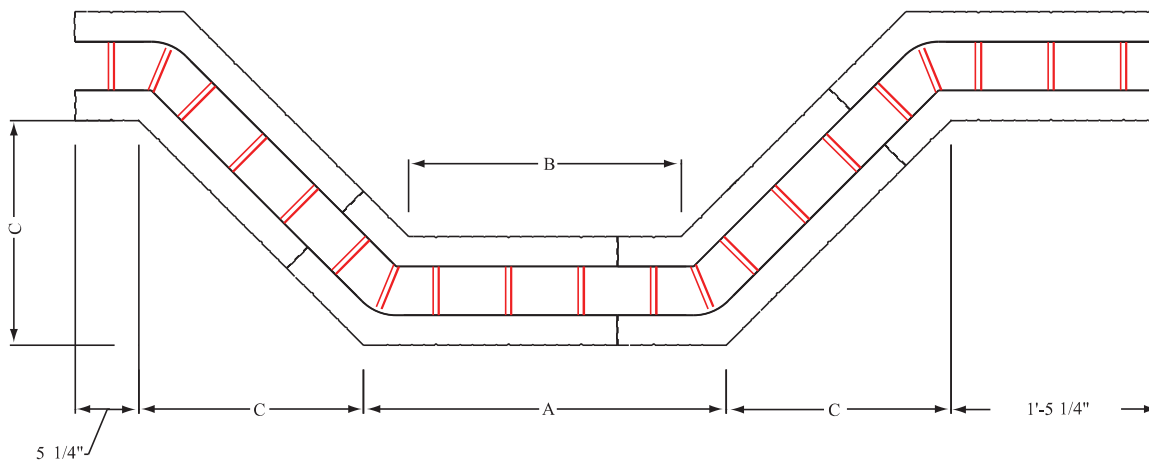

Table 3.8 - Preferred 45° Corner Dimensions for 6 inch Amvic Block⁽³⁾

Bay Projection Dimension C (ft - in)	Outside - Outside Bay Dimension A (ft - in)	Inside - Inside Bay Dimension B (ft - in)
9 13/16" (1)	1' 6 7/16" (1)	9 5/16" (1)
1' 2 1/16" (1)	2' 7/16" (1)	1' 3 5/16" (1)
1' 6 5/16" (2)	2' 6 7/16" (2)	1' 9 5/16" (2)
1' 10 9/16"	3' 7/16"	2' 3 5/16"
2' 2 13/16"	3' 6 7/16"	2' 9 5/16"
2' 7 1/16"	4' 7/16"	3' 3 5/16"
2' 11 5/16"	4' 6 7/16"	3' 9 5/16"
3' 3 9/16"	5' 7/16"	4' 3 5/16"
3' 7 13/16"	5' 6 7/16"	4' 9 5/16"
4' 1/16"	6' 7/16"	5' 3 5/16"
4' 4 5/16"	6' 6 7/16"	5' 9 5/16"
4' 8 9/16"	7' 7/16"	6' 3 5/16"
5' 13/16"	7' 6 7/16"	6' 9 5/16"
5' 5 1/16"	8' 7/16"	7' 3 5/16"
5' 9 5/16"	8' 6 7/16"	7' 9 5/16"
6' 3 9/16"	9' 7/16"	8' 3 5/16"

- (1) Minimum dimension required for a short corner with a stack joint
- (2) Minimum dimension required for a short corner with a running bond pattern
- (3) Red dimensions indicate use of full size Amvic blocks and no cutting required

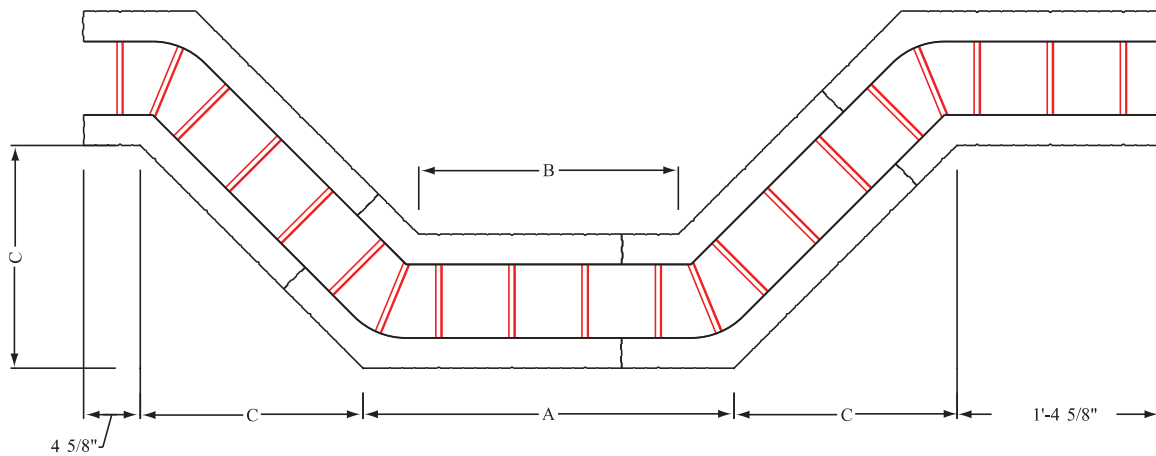
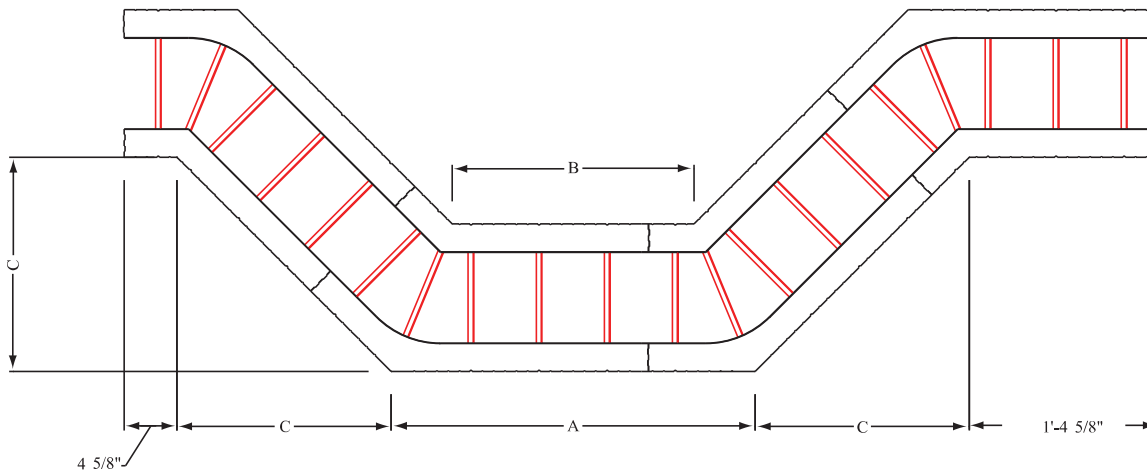

Table 3.9 - Preferred 45° Corner Dimensions for 8 inch Amvic Block⁽³⁾

Bay Projection Dimension C (ft - in)	Outside - Outside Bay Dimension A (ft - in)	Inside - Inside Bay Dimension B (ft - in)
10 3/8" (1)	1' 8 1/16" (1)	9 5/16" (1)
1' 2 5/8" (1)	2' 2 1/16" (1)	1' 3 5/16" (1)
1' 6 7/8" (2)	2' 8 1/16" (2)	1' 9 5/16" (2)
1' 11 1/8"	3' 2 1/16"	2' 3 5/16"
2' 3 3/8"	3' 8 1/16"	2' 9 5/16"
2' 7 5/8"	4' 2 1/16"	3' 3 5/16"
2' 11 7/8"	4' 8 1/16"	3' 9 5/16"
3' 4 1/8"	5' 2 1/16"	4' 3 5/16"
3' 8 3/8"	5' 8 1/16"	4' 9 5/16"
4' 5/8"	6' 2 1/16"	5' 3 5/16"
4' 4 7/8"	6' 8 1/16"	5' 9 5/16"
4' 9 1/8"	7' 2 1/16"	6' 3 5/16"
5' 1 3/8"	7' 8 1/16"	6' 9 5/16"
5' 5 5/8"	8' 2 1/16"	7' 3 5/16"
5' 9 7/8"	8' 8 1/16"	7' 9 5/16"
6' 2 1/8"	9' 2 1/16"	8' 3 5/16"

- (1) Minimum dimension required for a short corner with a stack joint
- (2) Minimum dimension required for a short corner with a running bond pattern
- (3) Red dimensions indicate use of full size Amvic blocks and no cutting required





Part 4 – Product Specification

Manufacturer

Amvic Building System

501 McNicoll Ave
Toronto, On
M2H 2E2

Phone: 416 410 5674
Toll Free: 1 877 470 9991
Fax: 416 759 7402

Website: www.amvicsystem.com

Product Description

Amvic Insulated Concrete Forms (ICFs) are stay-in-place forms manufactured using two 2.5" panels of Type 2 1.5lb/cf density Expanded Polystyrene (EPS) held together by polypropylene webs placed 6" on center. The forms offer a "5 in 1" system that provides structure, insulation, vapor barrier, sound barrier and attachments for drywall and exterior siding in one.

Completed Amvic ICF walls offer an R-Value of 22+, a performance R Value of 50+ when concrete thermal mass is included, an STC rating of 50+ and a fire rating of 3 hrs+ (for a 6" core or more).

Type of ICF: Flat Wall
Raw Materials: BASF BF or BFL 327 beads, polypropylene

Methods of Manufacturing: Molded raw beads through pressurized steam, Injection molded webs

Product Features

Amvic ICFs offer the following features which ensure exceptional quality as well reduce construction time and labour costs.



- **Form Capacity Strength of 865 lbs./sq.ft.**
- Fully reversible FormLock™ interlocking system with a depth of 1" which provides superior connection strength
- Webs have built-in clips which can hold 2 courses of reinforcing steel and place it most effectively to maximize structural strength
- Can withstand internal vibration
- Manufactured with over 60% recycled materials
- Generates less than 1% construction waste
- Can contribute up to 28 LEED points

Applications

Amvic ICF can be used both below and above grade for single and multi-storey residential, commercial, institutional and industrial construction.

Code Approvals

Amvic is approved by the following agencies:

- ICC-ES Report #1269
- CCMC Report #13043-R
- Bahamas Ministry of Works & Utilities. Report #MOW&U/BC/24/14
- City of Los Angeles, CA. Report #25477
- Ontario Ministry of Municipal Affairs & Housing, Report #02-02-89
- State of Florida
- State of Wisconsin

Technical Information and Support

Amvic has a comprehensive ICF Technical & Installation Manual available in print, on CD and on our website which covers detailed installation and technical information. Additional technical information is available on our website. If you require any other technical support please do not hesitate to contact our engineering department at 1 877 470 9991 ext 129.

Availability

Amvic ICFs are produced at multiple locations across North America and are available for purchase through Amvic's extensive network of Authorized Distributors.



USA		
Expanded Polystyrene in accordance with ICBO ES AC12 "Acceptance Criteria for Foam Plastic Insulation" In Conjunction with ASTM C578-95	Requirement	Amvic Results
1 - Expanded Polystyrene Testing ASTM C578-95		
Density (ASTM C 1622-98)	1.35 lbs/ft ³	1.5 lbs/ft ³
Thermal Resistance (ASTM C 177-97)	4.0 F.ft ² .h/Btu	4.0 F.ft ² .h/Btu
Compressive Strength (ASTM D 1621-94)	15.0 psi	19.8 psi
Flexural Strength (ASTM C 203-99)	40.0 psi min.	42.57 psi
Water Vapor Permeance (ASTM E 96-94)	200 max ng/Pa.s. s ²	130.1 ng/Pa.s.s ²
Water Absorption (ASTM C272-91)	3.0% by vol max	2.95%
Dimensional Stability (ASTM D 2126-94)	2.0% max	0.52%
Limiting Oxygen Index (ASTM D 2863-97)	24% min	37%
Trueness and Squareness (ASTM C 550-95)		
Edge Trueness	0.03125 in/ft max	0.0197 in/ft
Face Trueness	0.03125 in/ft max	0.0197 in/ft
Length and Width Squareness	0.0625 in/ft max	0.0295 in/ft
2 - Plastic Tie Testing ICBO ES AC116		
Fastener Withdrawal (ASTM D1761-99)	N/A	39.61 lbs Safety Factor of 5
Fastener Shear Strength (ASTM D1761-99)	N/A	60.22 lbs Safety Factor of 3.2
Tensile Strength (ASTM D638-99)	N/A	810 lbs at Ambient Temperature
3 - Fire Testing		
Room Fire Test (UBC 1997 26-3)	N/A	Passed/Complied
Other Testing		
A - Flammability ASTM E 84		
Flame Spread	25 max	25 or less
Smoke Developed	450 max	450 or less
B - Fire Burning Characteristics of Plastic Ties		
Ignition Temperature (ASTM D1929-68 (1975)	329 (C) 650 (F) min	400 (C) 752 (F)
Burn Rate (ASTM D635-98)	40 mm/min max	20.2 mm/min
Smoke Density (ASTM D2843-93)	75%	25.80%

CANADA		
Expanded Polystyrene In Accordance with Canadian Construction Material Center (CCMC) Technical Guide for "Modular Expanded - Polystyrene Concrete Forms" Master Format Section 03131 "	Requirement	Amvic Results
1 - Expanded Polystyrene Testing CAN/ULC S701-97, Type II		
Thermal Resistance (ASTM C177-97)	0.7 m ² .OC/W min	0.7 m ²
Water Vapor Permeance (ASTM E 96-94)	200 Ng/Pa.s. s ² max	130.1 Ng/Pa.s. s ² max
Dimensional Stability (ASTM D 2126-94)	1.5% max	0.52%
Flexural Strength (ASTM C 203-99)	240 KPa min	314.6 KPa
Water Absorption (ASTM D2842-97)	4.0% by vol max	0.93%
Compressive Strength (ASTM D 1621-94)	110 KPa min	136.5 Kpa
Limiting Oxygen Index (ASTM D 2863-97)	24% min	37%
2 - Plastic Web Testing CCMC Technical Guide		
Tensile Strength (ASTM D638-99)	N/A	810 lbs
Fastener Withdrawal (ASTM D1761-99)	N/A	198.04 lbs
Fastener Shear Strength (ASTM D1761-99)	N/A	226.08 lbs
3 - Forming Capacity Test section 6.4.4 of CCMC Technical Guide for Modular Expanded Polystyrene		
Forming Capacity	40 KPa (835 lbs/ft ²)	41.4 Kpa (865 lbs/ft ²)
Other Testing		
1 - Flammability CAN.4-S102.2		
Flame Spread	N/A	210
Smoke Developed	N/A	400-450
CANADA & USA		
1 - Fire Resistance Rating CAN/ULC S101-M89 and ASTM E119		
6 in wall with Drywall	N/A	3 hrs +
2 - 15 Minute Stay in Place Fire Test CAN/ULC S101-04 and ASTM E119-00a		
6 in wall with drywall	N/A	Passed/Complied

Specifications Chart

Product	Core	Form Dimension	Concrete Volume/Form	Concrete Volume/sq ft	Surface Area/Form
Straight	4"	48" x 16" x 9"	0.066 cu-yd	0.012 cu-yd	5.33 ft ²
	6"	48" x 16" x 11"	0.099 cu-yd	0.019 cu-yd	5.33 ft ²
Reversible Block	8"	48" x 16" x 13"	0.132 cu-yd	0.025 cu-yd	5.33 ft ²
	10"	48" x 24" x 15"	0.247 cu-yd	0.031 cu-yd	8 ft ²
90 Corner	4"	[24.5" + 12.5"] x 16" x 9"	0.037 cu-yd	0.009 cu-yd	4.11 ft ²
	6"	[26.5" + 14.5"] x 16" x 11"	0.059 cu-yd	0.013 cu-yd	4.56 ft ²
	8"	[28.5" + 16.5"] x 16" x 13"	0.083 cu-yd	0.017 cu-yd	5.00 ft ²
Reversible Block*	10"	[42.5" + 18.5"] x 24" x 15"	0.225 cu-yd	0.022 cu-yd	10.17 ft ²
	4"	[21" + 9"] x 16" x 9"	0.036 cu-yd	0.009 cu-yd	3.33 ft ²
45 Corner	6"	[21.25" + 9.25"] x 16" x 11"	0.05 cu-yd	0.015 cu-yd	3.38 ft ²
	8"	[22" + 10"] x 16" x 13"	0.068 cu-yd	0.019 cu-yd	3.56 ft ²
Taper Top Block	6"	48" x 16" x 11" - 9.5" * top	0.108 cu-yd	0.02 cu-yd	5.33 ft ²
	8"	48" x 16" x 13" - 11.5" **	0.141 cu-yd	0.026 cu-yd	5.33 ft ²
Brick Ledge Block	6"	48" x 16" & 5" **	0.134 cu-yd	0.025 cu-yd	5.33 ft ²
	8"	48" x 16" & 5" **	0.167 cu-yd	0.031 cu-yd	5.33 ft ²
	8"-6"	48" x 16" & 4.5" **	0.157 cu-yd	0.029 cu-yd	5.33 ft ²

*Concrete width at top **Brick ledge space



Part 5 – CSI Specifications

(Specifier Note: The purpose of this guide specification is to assist the specifier in correctly specifying AMVIC Insulating Concrete Forming products and execution. The specifier needs to edit the guide specifications to fit the needs of specific projects. Contact an AMVIC Product Representative to assist in making the appropriate product selections. Throughout the guide specification, there are Specifier notes to assist in the editing of the file.)

SECTION 03 11 19

INSULATING CONCRETE FORMING (ICF)

PART 1 GENERAL

1.01 SUMMARY

- A. Comply with the requirements for Division 1 - General Requirements.
- B. Supply and installation of **AMVIC** Insulating Concrete forms for structural cast-in-place concrete walls, installation of reinforcing steel bars and placement of concrete within the insulating concrete forms.
- C. Adequate bracing and scaffolding shall be provided by the installing contractor and shall comply with all applicable codes.

1.02 WORK SCOPE

- A. Furnish all labor, materials, tools and equipment to perform the installation of **AMVIC** insulating concrete forms as manufactured by **AMVIC INC.**
501 McNicoll Avenue, Toronto, Ontario, M2H 2E2, Canada
(416) 410-5674 / (877) 470-9991.
- D. Furnish all labor to install the steel reinforcing bars, placement of concrete into the insulating concrete forms and final cleanup.

1.03 PRODUCTS INSTALLED BUT NOT SPECIFIED OR SUPPLIED UNDER THIS SECTION

- A. Reinforcing Steel
- B. Concrete
- C. Anchor bolts, sleeves and inserts
- D. Window and door opening bucks



E. Penetrations

1.04 RELATED SECTIONS

(Specifier Note: ADD/DELETE/MODIFY the Section Numbers and Titles to correspond with specific project requirements. Related Sections to be added may include exterior wall finish, doors and window specific to project)

- A. Section 01 50 00 - Temporary Facility and Controls
- B. Section 03 05 00 - Basic Concrete Materials and Methods
- C. Section 03 10 00 - Concrete Forming and Accessories
- D. Section 03 20 00 - Concrete Reinforcement
- E. Section 03 30 00 - Cast-in-Place Concrete
- F. Section 03 40 00 - Pre-Cast Concrete
- G. Section 04 00 00 - Masonry
- H. Section 05 50 00 - Metal Fabrications
- I. Section 06 00 00 - Woods and Plastics
- J. Section 07 10 00 - Damp-proofing and Waterproofing
- K. Section 07 11 00 - Damp-proofing
- L. Section 07 13 00 - Sheet Waterproofing
- M. Section 07 24 00 - Exterior Insulation and Finish System
- N. Section 07 46 00 - Siding
- O. Section 07 60 00 - Flashing and sheet Metal
- P. Section 08 00 00 - Doors and Windows
- Q. Section 09 20 00 - Plaster and Gypsum Board
- R. Section 09 70 00 - Wall Finishes



1.05 REFERENCES

(Specifier Note: ADD/DELETE/MODIFY the Standards and references to correspond to the specific requirements and geographic location of the project.)

A. American Concrete Institute (ACI)

1. ACI 301- Standard Specification for Structural Concrete
2. ACI 318 - Building Code Requirements for Reinforced Concrete
3. ACI 332 - Guide to Residential Cast-in-Place Concrete Construction
3. ACI 347 - Guide to formwork for Concrete

B. Canadian Standards Association (CSA)

1. CSA A23.1 - Concrete Materials and Methods of Concrete Construction
2. CSA A23.2 - Methods of Test for Concrete
3. CSA A23.3 - Design of Concrete Structures
4. CSA S269.3 - Concrete Formwork

C. American Society for Testing and Materials (ASTM)

1. ASTM C203 - Standard Test Methods for Breaking Load and Flexural Properties of Block-Type Thermal Insulation
2. ASTM C272 - Standard Test Method for Water Absorption of Core Materials for Structural Sandwich Constructions
3. ASTM C303 - Standard Test Method for Dimensions and Density of Preformed Block-Type Thermal Insulation
4. ASTM C518 - Standard Test Method for Steady-State Thermal Transmission Properties by Means of the Heat Flow Meter Apparatus
5. ASTM D635 Standard Test Method for Rate of Burning and/or Extent and Time of Burning of Plastics in a Horizontal Position
6. ASTM D1621 Standard Test Method for Compressive Properties of Rigid Cellular Plastics
7. ASTM D1929 Standard Test Method for Determining Ignition Temperature of Plastics
8. ASTM D2126 - Standard Test Method for Response of Rigid Cellular Plastics to Thermal and Humid Aging



9. ASTM E 84 - Test Method for Surface Burning Characteristics of Building Materials
10. ASTM E 96 - Standard Test Methods for Water Vapor Transmission of Materials
11. ASTM E119 - Standard Test Methods for Fire Tests of Building Construction and Materials

(Specifier Note: DELETE reports that are not related to location of project)

D. US Evaluation Reports

1. International Code Council ICC report #ESR-1269
2. City of Los Angeles, California Report RR 25477

E. Canadian Construction Materials Centre (CCMC)

1. CCMC #13043-R

1.06 SYSTEM DESCRIPTION

- A. AMVIC ICF form blocks consist of two EPS foam plastic boards separated by injection molded polypropylene webs. The webs are spaced at 6 inches (152mm) on center.
- B. The webs are sized to maintain concrete core thicknesses of 4 inches (102mm), 6 inches (152mm), 8 inches (203mm) or 10 inches (254mm).
- C. The EPS boards are 16 inches (406mm) high by 48 inches (1220mm) long (the 10 inches core block is 24 inches (609.6mm) high. The thickness of the boards is 2.5 inches (63.5mm) each measured at the center of boards.
- D. EPS foam boards are molded from BASF BF or BFL 327 beads (ICBO ESR-3401). The foam plastic has a nominal density of 1.5 pcf (24.0 kg/m³), maximum smoke density rating of 450 and flame spread rating of 25 in accordance with ASTM E83.
- E. The foam plastic insulation complies as a type II rigid cellular polystyrene (RCPS) in accordance with ASTM C 578-95.
- F. The polypropylene webs have 1.5 inches (38.1mm) wide by 15 inches (381mm) high flanges. The flange is embedded 1/2 inch (12.7mm) below outside surface of the EPS foam boards to provide attachment for exterior and interior wall finishes.



1.07 SUBMITTALS

(Specifier Note: ADD/DELETE/MODIFY the Section Numbers and Titles to correspond with specific project requirements)

- A. Conform to requirements of Section 01 33 00 Submittal Procedures and Section 01 78 00 Closeout Submittals.
- B. Product Data: Submit manufacturer's literature describing products, installation procedures.
- C. Shop Drawings: Submit drawings indicating dimensions, layout, and form types and details.
- D. Test and Legacy Reports: When requested, submit test reports to support performance requirements specified and Legacy report approvals from (ICC), (CCMC - Canada), (City of Los Angeles) as required.
- E. Steel Reinforcement: Submit schedule of reinforcing.
- F. Concrete: Submit proposed concrete mix design.
- G. Engineering Calculations: Provide structural calculations sealed by a Professional Engineer.

1.08 QUALITY ASSURANCE

A. Qualifications

- 1. Installer Qualifications: Installer shall have a minimum of 3 years experience in the installation of ICF products and demonstrated experience with work of scope and scale equivalent to the project.

B. Pre-installation Meetings

- 1. Prior to starting ICF work, convene meeting at project site. Include trades responsible for installing forms, concrete, reinforcement and trades responsible for installing work that requires form modification.

C. Certifications

- 1. Manufacturer's signed certification that product meets the requirement of this section.

D. Approvals and Requirements

- 1. (ICC), (CCMC - Canada), (City of Los Angeles)



1.09 DELIVERY, STORAGE AND HANDLING

- A. Deliver the product in original factory packaging with product listing label and manufacturing label.
- B. Store materials in manufacturer provided bundles, to prevent damage. Protect from extended exposure to direct sunlight.
- C. Handle and store product in a location to prevent physical damage and soiling.

1.10 WARRANTY

- A. Contact AMVIC for a written copy of product warranty, OR
- B. Refer to requirements of the project contract for warranty provisions.

PART 2 PRODUCTS**2.01 MANUFACTURERS**

- A. AMVIC Building System
501 McNicoll Avenue,
Toronto, Ontario, M2H 2E2
Canada
Tel: 416-759-7402 / 1-877-470-9991
www.amvicsystem.com

2.02 MATERIALS

(Specifier Note: Section A is for the United States only and section B and D are for Canada only. Please delete sections not appropriate or applicable to project as necessary.)

- A. Expanded Polystyrene Type II Requirements as per **ASTM C578-95** Standard Specification for Rigid Cellular Polystyrene Thermal Insulation
 1. Density (**ASTM C 1622-98**) = 1.5 lbs/ft³ (**Required = 1.35 min**)
 2. Thermal Resistance (**ASTM C 177-97**) = 4.0 F.ft².h/Btu (**required = 4.0 min**)
 3. Compressive Strength (**ASTM D 1621-94**) = 19.8 psi (**required = 15.0 min**)
 4. Flexural Strength (**ASTM C 203-99**) = 42.57 psi (**required = 40.0 min**)



5. Water Vapor Permeance (ASTM E-96-94) = 130.1 ng/Pa.s.m²
(required = 200 max)
6. Water Absorption (ASTM C 272-91) = 2.95% (required = 3.0% max
by vol)
7. Dimensional Stability (ASTM D 2126-94) = 0.52% (required =
2.0% max)
8. Limiting Oxygen Index (ASTM D 2863-97) = 37% (required =
24% min)
9. Trueness and Squareness (ASTM C 550-95)
 - i. Edge Trueness = 0.0197inches/ft (required = 0.03125 max)
 - ii. Face Trueness = 0.0197inches/ft (required = 0.03125 max)
 - iii. Length and Width Squareness = 0.0295inches/ft (required =
0.0625 max)
10. Flammability (ASTM E 84)
 - i. Flame Spread Index = 25 or less (25 max)
 - ii. Smoke Development Index = 450 or Less (450 max)

B. Expanded Polystyrene Type II Requirements as per CAN/ULC-S701-97

1. Thermal Resistance (ASTM C 177-97) = 0.7 m². 0C/W (required =
0.7 min)
2. Water Vapor Permeance (ASTM E 96-94) = 130.1 ng/Pa.s.m² max
(required =200 max)
3. Dimensional Stability (ASTM D 2126-94) = 0.52% (required =
1.5% max)
4. Flexural Strength (ASTM C 203-99) = 314.6 KPa (required = 240 min)
5. Water Absorption (ASTM D2842-97) = 0.932% (required = 4.0% by
vol. max)
6. Compressive Strength (ASTM D 1621-94) = 136.5 KPa (required =
110 KPa min.)
7. Limiting Oxygen Index (ASTM D 2863-97) = 37% (required =
24% min)

C. Mechanical and Physical Properties of Plastic Tie and Interlocking Profiles in
accordance with ICBOES AC116 “Acceptance Criteria for Nail & Spikes” and
in conjunction with ASTM D 1761 (Standard Test Methods for Mechanical



Fasteners in Wood) and also in accordance with **CCMC** Technical Guide for “Modular Polystyrene Concrete Forms” Masterformat section 03131;

1. Type ‘S’ Fine thread drywall screw withdrawal load = 39.61 lbs (safety factor of 5)
2. Type ‘S’ Fine thread drywall lateral resistance load = 60.22 lbs (safety factor of 3.2)
3. Type ‘W’ coarse thread drywall screw withdrawal load= 38.42 lbs (safety factor of 5)
4. Type ‘W’ coarse thread drywall lateral resistance load = 50.56 lbs (safety factor of 4.46)
5. Tensile strength of web (**ASTM D 638-99**) = 253.3 lbs (safety factor of 3.2)
6. Ignition Temperature (**ASTM D 1929-68**) = 400°C (752°F), (min. required is (329°C/650°F)
7. Burn Rate (**ASTM D 635-98**) = 20.2 mm/min (max. is 40)
8. Smoke Density (**ASTM D 2843-93 / UBC 26-5**) = 25.8% (max. is 75%)

D. Forming capacity in accordance with section 6.4.4 of the **CCMC** Technical Guide for Modular Expanded Polystyrene Concrete Forms Masterformat 03131;

1. Forming Capacity = 41.4 KPa

E. Fire Rating in accordance with **CAN/ULC S101-M89** and **ASTM E119** “Standard Test Methods for Fire Tests of Building Construction and Materials”.

1. 6 inches concrete core (152mm) with 2.5 inches of EPS foam on both sides under load bearing conditions has a fire rating of 3+ hours.

F. Calculated **R-Value of 22+** wall assembly including exterior + interior foam panels, concrete core, stucco exterior and drywall interior.

G. **Sound Transmission Class (STC) of 49** for wall assembly including exterior + interior foam panels, 8 in. reinforced concrete core, stucco exterior and 5/8 inch drywall interior.

2.03 CONCRETE

A. Concrete supplied under section 03300 shall be normal weight with 3/8 to 1/2 inch (9.5 to 12.7 mm) aggregate size having a minimum compressive



strength of 3000 psi (20 MPa) at 28 days or as specified by the design engineer.

- B. Slump shall be between 5 to 6 inches (127 to 152 mm) with a water/cement ratio less than 0.55

2.04 STEEL

- A. Reinforcing steel grade, size, placement and spacing under section 03210 shall be as specified by the design engineer or prescriptive tables applicable to the specific project.

2.05 MANUFACTURED UNITS

- A. Two opposing faces of expanded polystyrene connected with polypropylene webs placed vertically 6 inches on center. Each web shall have support slots for horizontal reinforcing, and end plates on each side of the block for attaching interior and exterior finishes. Forms shall be preformed with interlocking edge to secure courses together.

(Specifier Note: DELETE units not appropriate for use on specific project)

B. Standard Reversible Straight Form Units

1. 4 inch wall width: Block Size 48 inches by 16 inches by 9 inches
2. 6 inch wall width: Block Size 48 inches by 16 inches by 11 inches
3. 8 inch wall width: Block Size 48 inches by 16 inches by 13 inches
4. 10 inch wall width: Block Size 48 inches by 24 inches by 15 inches

C. Standard 90° Reversible Corner Form Units

1. 4 inch wall width: Block Size (36-1/2 inches +12-1/2 inches) by 16 inches by 9 inches
2. 6 inch wall width: Block Size (26-1/2 inches +14-1/2 inches) by 16 inches by 11 inches
3. 8 inch wall width: Block Size (28-1/2 inches +16-1/2 inches) by 16 inches by 13 inches
4. 10 inch wall width: Block Size (42-1/2 inches +18-1/2 inches) by 24 inches by 15 inches



D. Standard 45° Reversible Corner Form Units

1. 4 inch wall width: Block Size (34 inches +10 inches) by 16 inches by 9 inches
2. 6 inch wall width: Block Size (22 inches +10 inches) by 16 inches by 11 inches
3. 8 inch wall width: Block Size (22 inches +10 inches) by 16 inches by 13 inches

E. Brick ledge forms

1. 8 inch brick ledge: Block Size 48 inches by 16 inches by 15.75 inches at top wide end.
2. 8 inch to 8 inch brick ledge: Block Size 48 inches by 16 inches by 18 inches at top wide end.
3. 6 inch to 6 inch brick ledge: Block Size 48 inches by 16 inches by 16 inches at top wide end.

F. Tapered Top forms

1. 6 inch taper top: Block Size 48 inches by 16 inches by 9.5 inches at top wide end.
2. 8 inch taper top: Block Size 48 inches by 16 inches by 11.5 inches at top wide end.

2.06 ACCESSORIES

- A. Bracing, wall alignment and scaffolding
- B. Anchor Bolts
- C. Door and Window Bucks
- D. Water proofing for below grade walls
- E. Sleeves for penetrations
- F. Exterior and interior finishes.



PART 3 EXECUTION

3.01 EXAMINATION

- A. Site Verification of Conditions: Verify lines, levels and centers before proceeding with formwork. Ensure dimension agree with drawings.

3.02 SURFACE PREPARATION

- A. Clean top of footings and slabs prior to starting installation of ICF. Use methods and materials approved by ICF manufacturer.
- B. Cast anchor dowels into concrete footing as per design engineer requirements and in co-ordination with ICF manufacturer recommended spacing and location related to the form size.

3.03 INSTALLATION – GENERAL

- A. Install Insulating Concrete Forming in accordance with manufacturer's installation methods. Protect forms from damage.
- B. Install formwork, shoring and bracing to achieve design requirements and in accordance with ACI 301.
- C. Provide bracing to ensure stability of formwork. Shore or strengthen formwork subject to over stressing by construction loads. Reinforce all cuts and weak spots.
- D. Align joints and install forms in a running bond pattern.
- E. Assure alignment of polypropylene furring strips to facilitate wall covering attachment.
- F. Install reinforcing, as indicated in engineered shop drawings, over opening to provide for integral lintels with the wall.

3.04 INSTALLATION – FORMS

- A. First Course
 - 1. Set corner forms.
 - 2. Set straight forms, starting at corner and working to center of wall, window or door location. Set forms through openings for 2 courses, to maintain interlock.



3. Cut final form to be placed. Maintain 2 inch cut increment line (center between two interlocks).
 4. Shim using EPS cuttings to adjust for footings and slabs out of level.
- B. Second Course: Build in same manner as first course. Staggering vertical joints a minimum of 12 inches.
- C. Attach base of wall using manufacturer recommended adhesive on side of wall with alignment system.
- D. Remove forms at openings, cutting 1/2 inch smaller to allow for adjustments.
- E. Continue placing form courses, cutting forms at openings, and placing reinforcement as required.
- F. Brace walls at 6 foot intervals and 2 feet at corners.
- G. Cut forms for utility penetrations.
- H. Install horizontal reinforcing as coursing progresses.
- I. Install manufactured alignment system following installation of fourth course.

3.05 CONSTRUCTION

A. Interface with Other Work

1. Provide formed openings where required for items to be embedded in or to pass through concrete work.
2. Locate and set items to be cast directly into concrete.
3. Coordinate with work of other trades in forming and placing openings, sleeves, bolts, anchors, other inserts.
4. Install accessories in accordance with manufacturer's instructions, straight, level and plumb. Ensure items are not disturbed during concrete placement.

B. Site Tolerances

1. Construct formwork to maintain tolerances as indicated per ACI 301 or CSA S269.3



3.06 FIELD QUALITY CONTROL

- A. Inspect erected formwork, shoring and bracing to ensure that work is in accordance with design, and that elements are secure.
- B. Site Tests: To be specified as required.

3.07 CLEANING

- A. Clean forms as installation proceeds, to remove foreign matter within forms.
- B. Clean formed cavities of debris prior to placing concrete.
- C. Flush with water or use compressed air to remove remaining foreign matter. Ensure that water and debris drain to exterior through clean-out ports.
- D. During cold weather, remove ice and snow from within forms. Do not use de-icing salts. Do not use water to clean out forms, unless formwork and concrete construction proceed within heated enclosure. Use compressed air or other means to remove foreign matter.





Part 6 – Engineering

6.1 – ICF Engineering

6.1.0 – Canada

Currently we have two main engineering resources for walls to be constructed with Amvic ICF.

1. **CCMC report no. 13043-R** which can be used as a reference for all Canadian provinces.
2. **National Building Code of Canada 2005 (NBC 2005)** upon which the individual provincial building codes of Canada's provinces are based.

Reinforced or plain concrete walls to be constructed using Amvic ICF and which are outside the applicability limits of **CCMC 13043-R** and **NBC 2005** shall be designed and approved by a local licensed/registered engineer.

6.1.1 – CCMC 13043-R

This report can be used and is recognized by most building departments of local cities, throughout Canada.

The report is available upon request and can be either downloaded from the Amvic website or from **Canadian Construction Material Centre** website as given below:

www.irc.nrc-cnrc.gc.ca/ccmc/regprodeval_e.shtml

6.1.2 – National Building Code of Canada 2005

The following articles and/or tables are reproduced from NBC 2005 and will have the specific NBC 2005 reference from which they were obtained.

6.1.2.1 – Application

All information given under section 6.1.2 is applicable to structures which fall under **Part 9 Housing and Small Buildings of NBC 2005**.



6.1.2.2 – Materials

1. Concrete

- a) [NBC 2005 - 9.3.1.1 (4)] For flat insulating concrete form walls not exceeding 2 storeys and having a maximum floor to floor height of 3m, in buildings of light frame construction containing only a single dwelling unit, the concrete and reinforcing shall comply with Part 4 or :

CAN/CSA-A23.1 “Concrete Materials and Methods of Concrete Construction” and maximum aggregate size of 19mm

- b) [NBC 2005 – 9.3.1.6 (1)] Compressive strength of un-reinforced concrete after 28 days shall be not less than **15 MPa** for walls, columns, fireplaces and chimneys, footings, foundation walls, grade beams and piers

2. Reinforcing Steel

[NBC 2005 – 9.3.1.1 (4)] Reinforcing shall:

- a) Conform to **CAN/CSA-G30.18-M** “Billet-Steel Bars for Concrete Reinforcement”
- b) Have a minimum Specified yield strength of **400 MPa**, and
- c) Be lapped a minimum of 450 mm for 10M bars and 650 mm for 15M bars

6.1.2.3 – Footings and Foundations

6.1.2.3.1 – Application

The articles and/or tables given in section 6.1.2.3 applies to:

[NBC 2005 – 9.15.1.1 (C)] Flat insulating concrete form foundation walls and concrete footings not subject to surcharge and:

- i) on stable soils with an allowable bearing pressure of 100 KPa (2000 lbs/sq.ft) or greater
- ii) for buildings of light frame or flat insulating concrete form construction that are not more than 2 storeys in building height, with a maximum floor to floor height of 3m, and containing only a single dwelling unit.



[NBC 2005 – 9.15.3.3] Minimum footing width shall apply to footings where

- a) the footings support
 - i) foundation walls of masonry, concrete or flat insulating concrete form walls
 - ii) above-ground walls of masonry, flat insulating concrete form walls or light wood frame construction and
 - iii) floors and roofs of light wood frame construction
- b) The span of supported joists does not exceed 4.9m, and
- c) The specified live load on any floor supported by the footing does not exceed 2.4 KPa.

6.1.2.3.2 – Minimum Footing Sizes

Footing Width

NBC 2005 - Table 9.15.3.4
Minimum Footing Sizes

No. of Floors Supported	Minimum Width of Strip Footings, mm		Minimum Footing Area for Columns Spaced 3m o.c.
	Supporting Exterior Walls (*1)	Supporting Interior Walls (*2)	
1	250	200	0.4
2	350	350	0.75
3	450	500	1.0

(*1) Adjustments to Footing Widths for Exterior Walls

[NBC 2005 – 9.15.3.5] The strip footing for exterior walls shown in table 9.15.3.4 shall be increased by

- a) 65 mm for each storey of masonry veneer over wood-frame construction supported by the foundation wall,
- b) 130 mm for each storey of masonry construction supported by the foundation wall, and
- c) 150 mm for each storey of flat insulating concrete form wall construction supported by the foundation wall

(*2) Adjustments to Footing Widths for Interior Walls

[NBC 2005 – 9.15.3.6 (1)] The minimum strip footing widths for interior load-bearing masonry walls shown in Table 9.15.3.4 shall be increased by 100 mm for each storey of masonry construction supported by the footing.



[NBC 2005 – 9.15.3.6 (2)] Footings for interior non-loadbearing masonry walls shall be not less than 200 mm wide for walls up to 5.5 m high and the widths shall be increased by 100 mm for each additional 2.7 m of height.

Footing Thickness

[NBC 2005 – 9.15.3.8] Footing thickness shall be not less than the greater of

- a) 100 mm, or
- b) the width of the projection of the footing beyond the supported element

6.1.2.4 – Foundation Walls

6.1.2.4.1 – Application

Application of the articles and/or tables given in section 6.1.2.4 is subject to the following conditions:

1. [NBC 2005 – 9.15.4.1 (1)] Insulating concrete form units shall be manufactured of polystyrene conforming to the performance requirements of CAN/ULC-S701 “Thermal Insulation Polystyrene, Boards and Pipe Covering” for type 2, 3 or 4 polystyrene.
2. [NBC 2005 – 9.15.4.2 (2)] The thickness of concrete in flat insulating concrete form foundation walls shall be not less than the greater of
 - a) 140 mm, or
 - b) the thickness of the concrete in the wall above
3. [NBC 2005 – 9.15.4.2 (3)] Foundation walls made of flat insulating concrete form units shall be laterally supported at the top and at the bottom. Please refer to articles 9.15.4.3 and 9.15.4.4 for determining bottom and top lateral support of walls.



6.1.2.4.2 – Reinforcement for Flat Insulating Concrete Form Foundation Walls

Horizontal Reinforcement

[NBC 2005 – 9.15.4.5 (1)] Horizontal reinforcement in flat insulating concrete form foundation walls shall

- a) consist of
 - ii) one 10M bar placed not more than 300 mm from the top of the wall, and
 - ii) 10M bars at 600 mm o.c. and
- b) be located
 - i) in the inside half of the wall section and
 - ii) with a minimum cover of 30 mm from the inside face of the concrete

Vertical Reinforcement

[NBC 2005 – 9.15.4.5 (2)] Vertical reinforcement in flat insulating concrete form foundation walls shall be

- a) provided in accordance with
 - i) **Table 9.15.4.5.A for 140 mm walls [use for 6 inch (152 mm) Amvic forms]**
 - ii) **Table 9.15.4.5.B for 190 mm walls [use for 8 inch (203 mm) Amvic forms]**
 - iii) **Table 9.15.4.5.C for 240 mm walls [use for 10 inch (254 mm) Amvic forms]**
- b) located in the inside half of the wall section with a minimum cover of 30 mm from the inside face of the concrete wall, and
- c) where interrupted by wall openings, placed not more than 600 mm from each side of the openings



Table 9.15.4.5.A
Vertical Reinforcement for 140 mm Flat Insulating Concrete Foundation Walls
[Amvic 6 inch (152 mm) Forms]

Max. Height of Finished Ground Above Finished Basement Floor, M	Minimum Vertical Reinforcement		
	Maximum Unsupported Basement Wall Height		
	2.44 m	2.75 m	3.0 m
1.35	10M at 400 mm o.c.	10M at 400 mm o.c.	10M at 400 mm o.c.
1.6	10M at 400 mm o.c.	10M at 380 mm o.c.	10M at 380 mm o.c.
2	10M at 380 mm o.c.	10M at 380 mm o.c.	10M at 380 mm o.c.
2.2	10M at 250 mm o.c.	10M at 250 mm o.c.	10M at 250 mm o.c.
2.35	n/a	10M at 250 mm o.c.	10M at 250 mm o.c.
2.6	n/a	10M at 250 mm o.c.	10M at 250 mm o.c.
3	n/a	n/a	10M at 250 mm o.c.

NBC 2005 - Table 9.15.4.5.B
Vertical Reinforcement for 190 mm Flat Insulating Concrete Foundation Walls
[Amvic 8 inch (203 mm) Forms]

Max. Height of Finished Ground Above Finished Basement Floor, m	Minimum Vertical Reinforcement		
	Maximum Unsupported Basement Wall Height		
	2.44 m	2.75 m	3.0 m
2.2	Not required	10M at 400 mm o.c.	10M at 400 mm o.c.
2.35	n/a	10M at 300 mm o.c.	10M at 300 mm o.c.
2.6	n/a	10M at 300 mm o.c.	10M at 400 mm o.c.
3	n/a	n/a	10M at 400 mm o.c.

NBC 2005 - Table 9.15.4.5.C
Vertical Reinforcement for 240 mm Flat Insulating Concrete Foundation Walls
[Amvic 10 inch (254 mm) Forms]

Max. Height of Finished Ground Above Finished Basement Floor, m	Minimum Vertical Reinforcement		
	Maximum Unsupported Basement Wall Height		
	2.44 m	2.75 m	3.0 m
2.2	Not required	10M at 400 mm o.c.	10M at 400 mm o.c.
2.35	n/a	10M at 300 mm o.c.	10M at 300 mm o.c.
2.6	n/a	10M at 300 mm o.c.	10M at 400 mm o.c.
3	n/a	n/a	10M at 400 mm o.c.

[NBC 2005 -9.15.4.5 (3)] Cold joints in flat insulating concrete form foundation walls shall be reinforced with no less than one 15M bar spaced at not more than 600 mm o.c. and embedded 300 mm on both sides of the joint.



6.1.2.5 – Above Grade Walls

6.1.2.5.1 – Application

The articles and/or tables given in section 6.1.2.5 applies to:

[NBC 2005 – 9.20.1.1 (1) (B)] Flat insulating concrete form walls not in contact with the ground that;

- i) have a maximum floor to floor height of 3m,
- ii) are erected in buildings not more than 2 storeys in building height and containing only a single dwelling unit, and
- iii) are erected in locations where the seismic spectral response accelerations, $S_a(0.2)$, is not greater than 0.4

6.1.2.5.2 – Thickness for Flat Insulating Concrete Form Walls

[NBC 2005 - 9.20.17.1 (1)] The thickness of the concrete in flat insulating concrete form walls not in contact with the ground shall be

- a) not less than 140 mm, and
- b) constant for the entire height of the wall

6.1.2.5.3 – Reinforcement for Flat Insulating Concrete Form Walls

Horizontal Reinforcement

[NBC 2005 – 9.20.17.2 (1)] Horizontal reinforcement in above-grade flat insulating concrete form walls shall

- a) consist of
 - i) one 10M bar placed not more than 300 mm from the top of the wall, and
 - ii) 10M bars at 600 mm o.c. and
- b) be placed in the middle third of the wall section



Vertical Reinforcement

[NBC 2005 – 9.20.17.2 (2)] Vertical reinforcement in above-grade flat insulating concrete form walls shall

- a) consist of 10M bars at 400 mm o.c. and
- b) be placed in the middle third of the wall section

[NBC 2005 – 9.20.17.2 (3)] Vertical reinforcement required by above sentence and interrupted by wall openings shall be placed not more than 600 mm from each side of the opening.

6.1.2.5.4 – Openings in Non-Loadbearing Flat ICF walls

[NBC 2005 – 9.20.17.3]

1. No openings shall occur within 1200 mm of interior and exterior corners of exterior non-load-bearing flat ICF walls
2. Portions of walls above openings in non-load-bearing flat ICF walls shall have a minimum depth of concrete of no less than 200 mm across the width of the opening.
3. Openings that are more than 600 mm but not more than 3000 mm in width in non-load-bearing flat ICF walls shall be reinforced at the top and bottom with one 10M bar.
4. Openings more than 3000 mm in width in non-load-bearing flat ICF walls shall be reinforced on all four sides with two 10M bars.
5. Reinforcing bars described in sentences (3) and (4) shall extend 600 mm beyond the edges of the opening.
6. The cumulative width of openings in non-load-bearing flat ICF walls shall not make up more than 70% of the length of any wall.

6.1.2.5.5 – Lintels over Openings in Load-bearing Flat ICF walls

[NBC 2005 – 9.20.17.4]

1. In load-bearing flat ICF walls, lintels shall be provided over all openings wider than 900 mm.
2. Lintels described in above sentence over openings wider than 1200 mm shall be reinforced for shear with 10M stirrups at a maximum spacing of half the distance from the bottom reinforcing bar to the top of the lintel.



6.1.2.5.6 – Framing Supported on Flat ICF walls

[NBC 2005 – 9.20.71.5]

1. Floor joists supported on the side of flat insulating concrete from walls shall be supported with joist hangers secured to wood ledger boards.
2. The ledger boards referred to in above sentence shall be not less than
 - a) 38 mm thick, and
 - b) the depth of the floor joists
3. Anchor bolts shall be used to secure ledger boards to flat ICF walls and shall be
 - a) embedded in the wall to a depth not less than 100 mm, and
 - b) spaced in accordance with table 9.20.17.5 (below)

NBC 2005 - Table 9.20.17.5
Maximum Anchor Bolt Spacing for the Connection of Floor Ledgers to Flat ICF walls

Maximum Clear Floor Span, m	Maximum Anchor Bolt Spacing, mm	
	Staggered 12.7 mm Diameter Anchor Bolts	Staggered 16 mm Diameter Anchor Bolts
2.44	450	500
3.0	400	450
4.0	300	400
5.0	275	325

6.1.2.5.7 – Anchoring of Roof Framing to Top Of Flat ICF walls

[NBC 2005 – 9.20.17.6]

1. Roof framing supported on the top of flat ICF walls shall be fixed to the top plates, which shall be anchored to the wall with anchor bolts
 - a) not less than 12.7 mm in diameter, and
 - b) spaced at not more than 1200 mm o.c
2. The anchor bolts described in above sentence shall be placed in the centre of the flat ICF wall and shall be embedded no less than 100 mm into the concrete.



6.2.0 – USA

There are two main resources for the engineering of flat ICF walls in the United States:

1. **Prescriptive Method for Insulating Concrete Forms in Residential Construction** prepared by NAHB (National Association of Home Builders) and PCA (Portland Cement Association). This document is widely recognized across most of the states, and is stated in the Amvic ICC (International Code Council) legacy report ESR-1269 as an approved engineering source.
2. **ACI 318 “Building Code Requirements for Structural Concrete”** is used for walls which are outside the scope and applicability limits of the Prescriptive Method. A local licensed/registered engineer is required to approve the design using this resource.

6.2.1 – Prescriptive Method

The prescriptive method book can be downloaded online from the following link:

www.huduser.org/publications/destech/icf_2ed.html

The articles and/or tables contained herein are reproduced from the prescriptive method and each will have the specific reference from which they were obtained.

6.2.1.1 – Scope

[Prescriptive Method 1.3]

1. The provisions of the **Prescriptive Method** apply to the construction of detached one- and two-family homes, townhouses, and other attached single-family dwellings in compliance with the general limitations of Table 1.1 (below).



**Prescriptive Method - TABLE 1.1
APPLICABILITY LIMITS**

ATTRIBUTE	MAXIMUM LIMITATION
General	
Number of Storeys	2 storeys above grade plus a basement
Design Wind Speed	150 mph (241 km/hr) 3-second gust (130 mph (209 km/hr) fastest-mile)
Ground Snow Load	70 psf (3.4 kPa)
Seismic Design Category	A, B, C, D1, and D2 (Seismic Zones 0, 1, 2, 3, and 4)
Foundations	
Unbalanced Backfill Height	9 feet (2.7 m)
Equivalent Fluid Density of Soil	60 pcf (960 kg/m ³)
Presumptive Soil Bearing Value	2,000 psf (96 kPa)
Walls	
Unit Weight of Concrete	150 pcf (23.6 kN/m ³)
Wall Height (unsupported)	10 feet (3 m)
Floors	
Floor Dead Load	15 psf (0.72 kPa)
First-Floor Live Load	40 psf (1.9 kPa)
Second-Floor Live Load (sleeping rooms)	30 psf (1.4 kPa)
Floor Clear Span (unsupported)	32 feet (9.8 m)
Roofs	
Maximum Roof Slope	12:12
Roof and Ceiling Dead Load	15 psf (0.72 kPa)
Roof Live Load (ground snow load)	70 psf (3.4 kPa)
Attic Live Load	20 psf (0.96 kPa)
Roof Clear Span (unsupported)	40 feet (12 m)

For SI: 1 foot = 0.3048 m; 1 psf = 47.8804 Pa; 1 pcf = 157.0877 N/m³ = 16.0179 kg/m³; 1 mph = 1.6093 km/hr

- An engineered design shall be required for houses built along the immediate, hurricane-prone coastline subjected to storm surge (i.e., beach front property) or in near-fault seismic hazard conditions (i.e., Seismic Design Category E).
- The provisions of the *Prescriptive Method* shall not apply to irregular structures or portions of structures in Seismic Design Categories C, D1, and D2.



6.2.1.2 – Material Specifications

ICF Size

[Prescriptive Method 2.1.1]

1. Flat ICF wall systems shall have a minimum concrete thickness of 5.5 inches (140 mm) for basement walls and 3.5 inches (89 mm) for above-grade walls.

Concrete Slump

[Prescriptive Method 2.2.1]

Ready-mixed concrete for ICF walls shall meet the requirements of ASTM C 94 [13]. Maximum slump shall not be greater than 6 inches (152 mm) as determined in accordance with ASTM C 143 [11]. Maximum aggregate size shall not be larger than 3/4 inch (19 mm).

Exception: Maximum slump requirements may be exceeded for approved concrete mixtures resistant to segregation, meeting the concrete compressive strength requirements, and in accordance with the ICF manufacturer's recommendations.

Concrete Compressive Strength

[Prescriptive Method 2.2.2]

1. The minimum specified compressive strength of concrete, f_c' , shall be 2,500 psi (17.2 MPa) at 28 days as determined in accordance with ASTM C 31 [8] and ASTM C 39 [9].
2. For Seismic Design Categories D₁ and D₂, the minimum compressive strength of concrete, f_c' , shall be 3,000 psi.

Reinforcing Steel

[Prescriptive Method 2.2.3]

1. Reinforcing steel used in ICFs shall meet the requirements of ASTM A 615 [14], ASTM A 996 [15], or ASTM A 706 [16].
2. In Seismic Design Categories D₁ and D₂, reinforcing steel shall meet the requirements of ASTM A706 [16] for low-alloy steel.



3. The minimum yield strength of the reinforcing steel shall be 40,000 psi, Grade 40 (300 MPa) except in Seismic Design Categories D1 and D2 where reinforcing steel shall have a minimum yield strength of 60,000 psi (Grade 60) (414 MPa).
4. Steel reinforcement shall have a minimum 3/4-inch (19mm) concrete cover.

EPS Materials

[Prescriptive Method 2.3]

1. Insulating concrete forms shall be constructed of rigid foam plastic meeting the requirements of ASTM C 578 [17].
2. Flame-spread rating of ICF forms that remain in place shall be less than 75 and smoke-development rating of such forms shall be less than 450, tested in accordance with ASTM E 84.



6.2.1.3 – Footings

[Prescriptive Method 3.1]

1. Minimum sizes for concrete footings shall be as set forth in Table 3.1 (below)

**Prescriptive Method - TABLE 3.1
APPLICABILITY LIMITS
FOOTINGS FOR ICF WALLS^{1,2,3} (Inches)**

Maximum Number of Storeys ⁴	MINIMUM LOAD BEARING VALUE OF SOIL (psf)				
	2,000	2,500	3,000	3,500	4,000
5.5 Inch Flat, 6-Inch Waffle Grid, or 6 Inch Screen Grid ICF Wall Thickness⁵					
One Storey ⁶	15	12	10	9	8
Two Storey ⁶	20	16	13	12	10
7.5-Inch Flat or 8-Inch Waffle-Grid, or 8-Inch Screen-Grid ICF Wall Thickness⁵					
One Storey ⁷	18	14	12	10	8
Two Storey ⁷	24	19	16	14	12
9.5-Inch Flat ICF Wall Thickness⁵					
One Storey	20	16	13	11	10
Two Storey	27	22	18	15	14

For SI: 1 foot = 0.3048 m; 1 inch = 25.4 mm; 1 psf = 47.8804 Pa

1-Minimum footing thickness shall be the greater of one-third of the footing width, 6 inches (152 mm), or 11 inches (279 mm) when a dowel is required in accordance with Section 6.0.

2-Footings shall have a width that allows for a nominal 2-inch (51-mm) projection from either face of the concrete in the wall to the edge of the footing.

3-Table values are based on 32 ft (9.8 m) building width (floor and roof clear span).

4-Basement walls shall not be considered as a storey in determining footing widths.

5-Actual thickness is shown for flat walls while nominal thickness is given for waffle- and screen-grid walls. Refer to Section 2.0 for actual waffle- and screen-grid thickness and dimensions.

6-Applicable also for 7.5-inch (191-mm) thick or 9.5-inch (241-mm) thick flat ICF foundation wall supporting 3.5-inch (88.9-mm) thick flat ICF storeys.

7-Applicable also for 9.5-inch (241-mm) thick flat ICF foundation wall storey supporting 5.5-inch (140-mm) thick flat ICF storeys.

2. Foundations erected on soils with a bearing value of less than 2,000 psf (96 KPa) shall be designed in accordance with accepted engineering practice.



6.2.1.3.1 – ICF Foundation Wall-to-Footing Connection

[Prescriptive Method – 6.1]

1. No vertical reinforcement (i.e. dowels) across the joint between the foundation wall and the footing is required when one of the following exists:
 - The unbalanced backfill height does not exceed 4 feet (1.2 m)
 - The interior floor slab is installed in accordance with Figure 3.3 before backfilling.
 - Temporary bracing at the bottom of the foundation wall is erected before backfilling and remains in place during construction until an interior floor slab is installed in accordance with Figure 3.3 or the wall is backfilled on both sides (i.e. stem wall).
2. For foundation walls that do not meet one of the above requirements, vertical reinforcement (i.e. dowel) shall be installed across the joint between the foundation wall and the footing at 48 inches (1.2 m) on center in accordance with Figure 6.1.
3. Vertical reinforcement (i.e. dowels) shall be provided for all foundation walls for buildings located in regions with 3 second gust design wind speeds greater than 130 mph (209 km/hr) or located in Seismic Design Categories D1 and D2 at 18 inches (457 mm) on center.

Exception: The foundation wall's vertical wall reinforcement at intervals of 4 feet (1.2 m) on center shall extend 8 inches (203 mm) into the footing in lieu of using a dowel as shown in Figure 6.1.

6.2.1.4 – Foundation Wall Requirements

Crawlspace Walls

[Prescriptive Method – 3.2.2]

Applicable to walls 5 feet (1.5m) or less in height with a maximum unbalanced backfill height of 4 feet (1.2m) for a one-storey construction with floor bearing on top of crawlspace wall.

1. ICF crawlspace walls shall be laterally supported at the top and bottom of the wall in accordance with Section 6.0.
2. A minimum of one horizontal no. 4 bar shall be placed within 12 inches (305mm) of the top of the crawlspace wall.



3. Vertical reinforcement shall be as per table 3.2 (below). For crawlspace walls carrying ICF wall on top, vertical reinforcement shall be the greater of that required in table 3.2 or table 4.2 in the following section

**Prescriptive Method - TABLE 3.2
MINIMUM VERTICAL WALL REINFORCEMENT FOR
ICF CRAWLSPACE WALLS ^{1,2,3,4,5,6}**

SHAPE OF CONCRETE WALLS	WALL THICKNESS ⁷ (inches)	MINIMUM VERTICAL REINFORCEMENT		
		MAXIMUM EQUIVALENT FLUID DENSITY 30 pcf	MAXIMUM EQUIVALENT FLUID DENSITY 45 pcf	MAXIMUM EQUIVALENT FLUID DENSITY 60 pcf
Flat	3.5 ⁸	#3 @ 16"; #4 @ 32"	#3 @ 18"; #4 @ 28"; #5 @ 38"	#3 @ 12"; #4 @ 22"; #5 @ 28"
	5.5	#3 @ 24"; #4 @ 48"	#3 @ 24"; #4 @ 48"	#3 @ 24"; #4 @ 48"
	7.5	N/R	N/R	N/R

For SI: 1 foot = 0.3048 m; 1 inch = 25.4 mm; 1 pcf = 16.0179 kg/m³

- 1 - Table values are based on reinforcing bars with a minimum yield strength of 40,000 psi (276 MPa) and concrete with a minimum specified compressive strength of 2,500 psi (17.2 MPa).
- 2 - N/R indicates no vertical wall reinforcement is required.
- 3 - Spacing of rebar shall be permitted to be multiplied by 1.5 when reinforcing steel with a minimum yield strength of 60,000 psi (414 MPa) is used. Reinforcement, when required, shall not be less than one #4 bar at 48 inches (1.2 m) on center.
- 4 - Applicable only to crawlspace walls 5 feet (1.5 m) or less in height with a maximum unbalanced backfill height of 4 feet (1.2 m).
- 5 - Interpolation shall not be permitted.
- 6 - Walls shall be laterally supported at the top before backfilling.
- 7 - Actual thickness is shown for flat walls while nominal thickness is given for waffle-and screen-grid walls. Refer to Section 2.0 for actual waffle- and screen-grid thickness and dimensions.
- 8 - Applicable only to one-storey construction with floor bearing on top of crawlspace wall.



Basement Walls

[Prescriptive Method – 3.2.3]

1. Basement walls shall be laterally supported at the top and bottom of the wall in accordance with section 6.0.
2. Minimum horizontal reinforcement shall be as per table 3.3 (below)

**Prescriptive Method - TABLE 3.3
MINIMUM HORIZONTAL WALL REINFORCEMENT FOR
ICF BASEMENT WALLS**

MAXIMUM HEIGHT OF BASEMENT WALL FEET (METERS)	LOCATION OF HORIZONTAL REINFORCEMENT
8 (2.4)	One No.4 bar within 12 inches (305 mm) of the top of the wall storey and one No.4 bar near mid-height of the wall storey
9 (2.7)	One No.4 bar within 12 inches (305 mm) of the top of the wall storey and one No.4 bar near third points in the wall storey
10 (3.0)	One No.4 bar within 12 inches (305 mm) of the top of the wall storey and one No.4 bar near third points in the wall storey

For SI: 1 foot = 0.3048 m; 1 inch = 25.4 mm; 1 pcf = 16.0179 kg/m³

Horizontal reinforcement requirements are for reinforcing bars with a minimum yield strength from 40,000 psi (276 MPa) and concrete with a minimum concrete compressive strength of 2,500 psi (17.2 Mpa)

3. Vertical wall reinforcement shall be as per the following tables:
 - a) Prescriptive Method Table 3.4 – For use with Amvic 6 inch (152 mm) basement walls.
 - b) Prescriptive Method Table 3.5 – For use with Amvic 8 inch (203 mm) basement walls.
 - c) Prescriptive Method Table 3.6 – For use with Amvic 10 inch (254 mm) basement walls.



**Prescriptive Method - TABLE 3.4
MINIMUM VERTICAL WALL REINFORCEMENT FOR
5.5 inch (140 mm) THICK FLAT ICF BASEMENT WALLS ^{1,2,3,4,5}**

MAX WALL HEIGHT (feet)	MAXIMUM UNBALANCED BACKFILL HEIGHT ⁶ (feet)	MINIMUM VERTICAL REINFORCEMENT		
		MAXIMUM EQUIVALENT FLUID DENSITY 30 pcf	MAXIMUM EQUIVALENT FLUID DENSITY 45 pcf	MAXIMUM EQUIVALENT FLUID DENSITY 60 pcf
8	4	#4@48"	#4@48"	#4@48"
	5	#4@48"	#3@12"; #4@22"; #5@32"; #6@40"	#3@8"; #4@14"; #5@20"; #6@26"
	6	#3@12"; #4@22"; #5@30"; #6@40"	#3@8"; #4@14"; #5@20"; #6@24"	#3@6"; #4@10"; #5@14"; #6@20"
	7	#3@8"; #4@14"; #5@22"; #6@26"	#3@5"; #4@10"; #5@14"; #6@18"	#3@4"; #4@6"; #5@10"; #6@14"
9	4	#4@48"	#4@48"	#4@48"
	5	#4@48"	#3@12"; #4@20"; #5@28"; #6@36"	#3@8"; #4@14"; #5@20"; #6@22"
	6	#3@10"; #4@20"; #5@28"; #6@34"	#3@6"; #4@12"; #5@18"; #6@20"	#4@8"; #5@14"; #6@16"
	7	#3@8"; #4@14"; #5@20"; #6@22"	#4@8"; #5@12"; #6@16"	#4@6"; #5@10"; #6@12"
	8	#3@6"; #4@10"; #5@14"; #6@16"	#4@6"; #5@10"; #6@12"	#4@4"; #5@6"; #6@8"
10	4	#4@48"	#4@48"	#4@48"
	5	#4@48"	#3@10"; #4@18"; #5@26"; #6@30"	#3@6"; #4@14"; #5@18"; #6@20"
	6	#3@10"; #4@18"; #5@24"; #6@30"	#3@6"; #4@12"; #5@16"; #6@18"	#3@4"; #4@8"; #5@12"; #6@14"
	7	#3@6"; #4@12"; #5@16"; #6@18"	#3@4"; #4@8"; #5@12"	#4@6"; #5@8"; #6@10"
	8	#3@4"; #4@8"; #5@12"; #6@14"	#4@6"; #5@8"; #6@12"	#4@4"; #5@6"; #6@8"
	9	#3@4"; #4@6"; #5@10"; #6@12"	#4@4"; #5@6"; #6@8"	#5@4"; #6@6"
			#5@10"; #6@12"	#6@8"

For SI: 1 foot = 0.3048 m; 1 inch = 25.4 mm; 1 pcf = 16.0179 kg/m³

- 1 - Table values are based on reinforcing bars with a minimum yield strength of 40,000 psi (276 MPa) and concrete with a minimum specified compressive strength of 2,500 psi (17.2 MPa).
- 2 - Spacing of rebar shall be permitted to be multiplied by 1.5 when reinforcing steel with a minimum yield strength of 60,000 psi (414 MPa) is used. Reinforcement shall not be less than one #4 bar at 48 inches (1.2 m) on center.
- 3 - Deflection criterion is L/240, where L is the height of the basement wall in inches.
- 4 - Interpolation shall not be permitted.
- 5 - Walls shall be laterally supported at the top before backfilling.
- 6 - Refer to Section 1.0 for the definition of unbalanced backfill height.



**Prescriptive Method - TABLE 3.5
MINIMUM VERTICAL WALL REINFORCEMENT FOR
7.5 inch (191 mm) THICK FLAT ICF BASEMENT WALLS ^{1,2,3,4,5,6}**

MAX WALL HEIGHT (feet)	MAXIMUM UNBALANCED BACKFILL HEIGHT ⁷ (feet)	MINIMUM VERTICAL REINFORCEMENT		
		MAXIMUM EQUIVALENT FLUID DENSITY 30 pcf	MAXIMUM EQUIVALENT FLUID DENSITY 45 pcf	MAXIMUM EQUIVALENT FLUID DENSITY 60 pcf
8	4	N/R	N/R	N/R
	5	N/R	N/R	N/R
	6	N/R	N/R	N/R
	7	N/R	#4@14"; #5@20"; #6@28"	#4@10"; #5@16"; #6@20"
9	4	N/R	N/R	N/R
	5	N/R	N/R	N/R
	6	N/R	N/R	#4@14"; #5@20"; #6@28"
	7	N/R	#4@12"; #5@18"; #6@26"	#4@8"; #5@14"; #6@18"
	8	#4@14"; #5@22"; #6@28"	#4@8"; #5@14"; #6@18"	#4@6"; #5@10"; #6@14"
10	4	N/R	N/R	N/R
	5	N/R	N/R	N/R
	6	N/R	N/R	#4@12"; #5@18"; #6@26"
	7	N/R	#4@12"; #5@18"; #6@24"	#4@8"; #5@12"; #6@18"
	8	#4@12"; #5@20"; #6@26"	#4@8"; #5@12"; #6@16"	#4@6"; #5@8"; #6@12"
	9	#4@10"; #5@14"; #6@20"	#4@6"; #5@10"; #6@12"	#4@4"; #5@6"; #6@10"

For SI: 1 foot = 0.3048 m; 1 inch = 25.4 mm; 1 pcf = 16.0179 kg/m³

- 1 - Table values are based on reinforcing bars with a minimum yield strength of 40,000 psi (276 MPa) and concrete with a minimum specified compressive strength of 2,500 psi (17.2 MPa).
- 2 - Spacing of rebar shall be permitted to be multiplied by 1.5 when reinforcing steel with a minimum yield strength of 60,000 psi (414 MPa) is used. Reinforcement, when required, shall not be less than one #4 bar at 48 inches (1.2 m) on center.
- 3 - N/R indicates no reinforcement is required.
- 4 - Deflection criterion is L/240, where L is the height of the basement wall in inches.
- 5 - Interpolation shall not be permitted.
- 6 - Walls shall be laterally supported at the top before backfilling.
- 7 - Refer to Section 1.0 for the definition of unbalanced backfill height.



Prescriptive Method - TABLE 3.6
MINIMUM VERTICAL WALL REINFORCEMENT FOR
9.5 inch (241 mm) THICK FLAT ICF BASEMENT WALLS ^{1,2,3,4,5,6}

MAX WALL HEIGHT (feet)	MAXIMUM UNBALANCED BACKFILL HEIGHT ⁷ (feet)	MINIMUM VERTICAL REINFORCEMENT		
		MAXIMUM EQUIVALENT FLUID DENSITY 30 pcf	MAXIMUM EQUIVALENT FLUID DENSITY 45 pcf	MAXIMUM EQUIVALENT FLUID DENSITY 60 pcf
8	4	N/R	N/R	N/R
	5	N/R	N/R	N/R
	6	N/R	N/R	N/R
	7	N/R	N/R	N/R
9	4	N/R	N/R	N/R
	5	N/R	N/R	N/R
	6	N/R	N/R	N/R
	7	N/R	N/R	#4@12"; #5@18"; #6@26"
10	8	N/R	#4@12"; #5@18"; #6@26"	#4@8"; #5@14"; #6@18"
	4	N/R	N/R	N/R
	5	N/R	N/R	N/R
	6	N/R	N/R	#4@18"; #5@26"; #6@36"
	7	N/R	N/R	#4@10"; #5@18"; #6@24"
	8	N/R	#4@12"; #5@16"; #6@24"	#4@8"; #5@12"; #6@16"
9	N/R	#4@8"; #5@12"; #6@18"	#4@6"; #5@10"; #6@12"	

For SI: 1 foot = 0.3048 m; 1 inch = 25.4 mm; 1 pcf = 16.0179 kg/m³

- 1 - Table values are based on reinforcing bars with a minimum yield strength of 40,000 psi (276 MPa) and concrete with a minimum specified compressive strength of 2,500 psi (17.2 MPa).
- 2 - Spacing of rebar shall be permitted to be multiplied by 1.5 when reinforcing steel with a minimum yield strength of 60,000 psi (414 MPa) is used. Reinforcement, when required, shall not be less than one #4 bar at 48 inches (1.2 m) on center.
- 3 - N/R indicates no reinforcement is required.
- 4 - Deflection criterion is L/240, where L is the height of the basement wall in inches.
- 5 - Interpolation shall not be permitted.
- 6 - Walls shall be laterally supported at the top before backfilling.
- 7 - Refer to Section 1.0 for the definition of unbalanced backfill height.



Seismic Requirements for Basement Walls

[Prescriptive Method – 3.2.4]

1. Concrete foundation walls supporting above-grade ICF walls in Seismic Design Category C shall be reinforced with minimum No. 5 rebar at 24 inches (610 mm) on center (both ways) or a lesser spacing if required by Tables 3.2 through 3.6
2. Concrete foundation walls supporting above grade ICF walls in Seismic Design Categories D1 and D2 shall be reinforced with minimum No. 5 rebar at a maximum spacing of 18 inches (457 mm) on center (both ways) or a lesser spacing if required by Tables 3.2 through 3.6 and the minimum concrete compressive strength shall be 3,000 psi (20.5 MPa). Vertical reinforcement shall be continuous with ICF above grade wall vertical reinforcement. Alternatively, the reinforcement shall extend a minimum of 40db into the ICF above grade wall, creating a lap-splice with the above-grade wall reinforcement or extend 24 inches (610 mm) terminating with a minimum 90 degree bend of 6 inches in length.



6.2.1.5 – Above Grade Walls

Wind Pressures

[Prescriptive Method – 4.1]

1. Design Wind pressures of table 4.1 (below) shall be used to determine the vertical wall reinforcement requirements.

**Prescriptive Method - TABLE 4.1
DESIGN WIND PRESSURE FOR USE WITH MINIMUM VERTICAL WALL REINFORCEMENT
TABLES FOR ABOVE GRADE WALLS¹**

WIND SPEED (mph)	DESIGN WIND PRESSURE (psf)					
	ENCLOSED ²			PARTIALLY ENCLOSED		
	Exposure ³			Exposure ³		
	B	C	D	B	C	D
85	18	24	29	23	31	37
90	20	27	32	25	35	41
100	24	34	39	31	43	51
110	29	41	48	38	52	61
120	35	48	57	45	62	73
130	41	56	66	53	73	85
140	47	65	77	61	84	99
150	54	75	88	70	96	114

For SI: 1 psf = 0.0479 kN/m²; 1 mph = 1.6093 km/hr

- 1 - This table is based on ASCE 7-98 components and cladding wind pressures using a mean roof height of 35 ft (10.7 m) and a tributary area of 10 ft² (0.9 m²).
- 2 - Enclosure Classifications are as defined in Section 1.5.
- 3 - Exposure Categories are as defined in Section 1.5.
- 4 - For wind pressures greater than 80 psf (3.8 kN/m²), design is required in accordance with accepted practice and approved manufacturer guidelines.

2. If relying on fastest mile speed maps or design provisions based on fastest wind speeds, the designer should convert wind speeds to 3 second gust wind in accordance with Table C1.1 for use with the given tables in this section.

**Prescriptive Method - TABLE C1.1
WIND SPEED CONVERSIONS**

Fastest Mile (mph)	70	75	80	90	100	110	120	130
3-second Gust (mph)	85	90	100	110	120	130	140	150



**Prescriptive Method - TABLE 4.2
MINIMUM VERTICAL WALL REINFORCEMENT
FOR FLAT ICF ABOVE-GRADE WALLS^{1,2,3}**

DESIGN WIND PRESSURE (TABLE 4.1) (psf)	MAXIMUM WALL HEIGHT PER STOREY (feet)	MINIMUM VERTICAL REINFORCEMENT ^{4,5}					
		SUPPORTING ROOF OR NON-LOAD-BEARING WALL		SUPPORTING LIGHT FRAME SECOND STOREY AND ROOF		SUPPORTING ICF SECOND STOREY AND LIGHT FRAME ROOF	
		MINIMUM WALL THICKNESS (inches)					
		3.5	5.5	3.5	5.5	3.5	5.5
20	8	#4@48"	#4@48"	#4@48"	#4@48"	#4@48"	#4@48"
	9	#4@48"	#4@48"	#4@48"	#4@48"	#4@48"	#4@48"
	10	#4@38"	#4@48"	#4@40"	#4@48"	#4@42"	#4@48"
30	8	#4@42"	#4@48"	#4@46"	#4@48"	#4@48"	#4@48"
	9	#4@32"; #5@48"	#4@48"	#4@34"; #5@48"	#4@48"	#4@34"; #5@48"	#4@48"
	10	Design Required	#4@48"	Design Required	#4@48"	Design Required	#4@48"
40	8	#4@30"; #5@48"	#4@48"	#4@30"; #5@48"	#4@48"	#4@32"; #5@48"	#4@48"
	9	Design Required	#4@42"	Design Required	#4@46"	Design Required	#4@48"
	10	Design Required	#4@32"; #5@48"	Design Required	#4@34"; #5@48"	Design Required	#4@38"
50	8	#4@20"; #5@30"	#4@42"	#4@22"; #5@34"	#4@46"	#4@24"; #5@36"	#4@48"
	9	Design Required	#4@34"; #5@48"	Design Required	#4@34"; #5@48"	Design Required	#4@38"
	10	Design Required	#4@26"; #5@38"	Design Required	#4@26"; #5@38"	Design Required	#4@28"; #5@46"
60	8	Design Required	#4@34"; #5@48"	Design Required	#4@36"	Design Required	#4@40"
	9	Design Required	#4@26"; #5@38"	Design Required	#4@28"; #5@46"	Design Required	#4@34"; #5@48"
	10	Design Required	#4@22"; #5@34"	Design Required	#4@22"; #5@34"	Design Required	#4@26"; #5@38"
70	8	Design Required	#4@28"; #5@46"	Design Required	#4@30"; #5@48"	Design Required	#4@34"; #5@48"
	9	Design Required	#4@22"; #5@34"	Design Required	#4@22"; #5@34"	Design Required	#4@24"; #5@36"
	10	Design Required	#4@16"; #5@26"	Design Required	#4@18"; #5@28"	Design Required	#4@20"; #5@30"
80	8	Design Required	#4@26"; #5@38"	Design Required	#4@26"; #5@38"	Design Required	#4@28"; #5@46"
	9	Design Required	#4@20"; #5@30"	Design Required	#4@20"; #5@30"	Design Required	#4@21"; #5@34"
	10	Design Required	#4@14"; #5@24"	Design Required	#4@14"; #5@24"	Design Required	#4@16"; #5@26"

For SI: 1 foot = 0.3048 m; 1 inch = 25.4 mm; 1 mph = 1.6093 km/hr

- 1 - This table is based on reinforcing bars with a minimum yield strength of 40,000 psi (276 Mpa) and concrete with a minimum specified compression strength of 2,500 psi (17.2 Mpa)
- 2 - Deflection criterion is L/240 where L is the height of the wall storey in inches.
- 3 - Interpolation shall not be permitted.
- 4 - Reinforcement spacing for 3.5 inch (88.9 mm) walls shall be permitted to be multiplied by 1.6 when reinforcing steel with a minimum yield strength of 60,000 psi (414 Mpa) is used. Reinforcement shall not be less than one #4 bar at 48 inches (1.2m) on center.
- 5 - Reinforcement spacing for 5.5 inch (139.7 mm) walls shall be permitted to be multiplied by 1.5 when reinforcing steel with a minimum yield strength of 60,000 psi (414 Mpa) is used. Reinforcement shall not be less than one #4 bar at 48 inches (1.2m) on center.
- 6 - A 3.5 inch wall shall not be permitted if wood ledgers are used to support floor or roof loads.



Above Grade Wall Reinforcement

[Prescriptive Method – 4.1]

1. Horizontal wall reinforcement shall be required in the form of one No. 4 rebar within 12 inches (305 mm) from the top of the wall, one No. 4 rebar within 12 inches (305 mm) from the finish floor, and one No. 4 rebar near one-third points throughout the remainder of the wall.
2. The vertical wall reinforcement shall be as per the Prescriptive Method table 4.2 (below). This table can be used for Amvic 4 inch (100 mm) and 6 inch (152 mm) above grade ICF walls.

Seismic & Wind Requirements

[Prescriptive Method – 4.1]

1. In Seismic Design Category C, the minimum vertical and horizontal reinforcement shall be one No. 5 rebar at 24 inches (610 mm) on center or lesser spacing if required by table 4.2.
2. In Seismic Design Categories D1 and D2, the minimum vertical and horizontal reinforcement shall be one No. 5 rebar at a maximum spacing of 18 inches (457 mm) on center or lesser spacing if required by table 4.2 and the minimum concrete compressive strength shall be 3,000 psi (20.5 MPa).
3. For design wind pressure greater than 40 psf (1.9 kPa) or Seismic Design Category C or greater, all vertical wall reinforcement in the top-most ICF storey shall be terminated with a 90 degree bend. The bend shall result in a minimum length of 6 inches (152 mm) parallel to the horizontal wall reinforcement and lie within 4 inches (102 mm) of the top surface of the ICF wall. In addition, horizontal wall reinforcement at exterior building corners shall be terminated with a 90 degree bend resulting in a minimum lap splice length of 40db with the horizontal reinforcement in the intersecting wall. The radius of bends shall not be less than 4 inches (102 mm).



Seismic & Wind Wall Opening Requirements**[Prescriptive Method – 5.1]**

1. For minimum amount of solid wall length for different wind pressures, please refer to prescriptive tables 5.1, 5.2A, 5.2B and 5.2C (below).

**Prescriptive Method - TABLE 5.1
WIND VELOCITY PRESSURE FOR DETERMINATION OF MINIMUM
SOLID WALL LENGTH¹**

WIND SPEED (mph)	VELOCITY PRESSURE (psf)		
	Exposure ²		
	B	C	D
85	14	19	23
90	16	21	25
100	19	26	31
110	23	32	37
120	27	38	44
130	32	44	52
140	37	51	60
150	43	59	69 ³

For SI: 1 psf = 0.0479 kN/m²; 1 mph = 1.6093 km/hr

1 - Table values are based on ASCE 7-98 Figure 6-4 wind velocity pressures for low-rise buildings using a mean roof height of 35 ft (10.7 m).

2 - Exposure Categories are as defined in Section 1.5.

3 - Design is required in accordance with acceptable practice and approved manufacturer guidelines.



**Prescriptive Method - TABLE 5.2A
MINIMUM SOLID END WALL
REQUIREMENTS FOR FLAT ICF WALLS
(WIND PERPENDICULAR TO RIDGE)^{1,2,3,4,5}**

DESIGN VELOCITY PRESSURE (psf)			20	25	30	35	40	45	50	60	
WALL CATEGORY	BUILDING SIDE WALL LENGTH, L (feet)	ROOF SLOPE	MINIMUM SOLID WALL LENGTH ON BUILDING END WALL (feet)								
			One-storey or Top Storey of Two-Storey	16	≤ 1:12	4.00	4.00	4.00	4.00	4.00	4.00
5:12	4.00	4.00			4.00	4.00	4.00	4.00	4.00	4.25	4.50
7:12 ⁴	4.00	4.25			4.25	4.50	4.75	4.75	4.75	5.00	5.50
12:12 ⁴	4.25	4.50			4.75	5.00	5.25	5.50	5.50	5.75	6.25
24	≤ 1:12	4.00		4.00	4.00	4.00	4.00	4.00	4.00	4.25	4.50
	5:12	4.00		4.00	4.00	4.25	4.25	4.50	4.50	4.50	4.75
	7:12 ⁴	4.25		4.50	4.75	5.00	5.25	5.50	5.50	5.75	6.25
	12:12 ⁴	4.75		5.00	5.25	5.75	6.00	6.50	6.50	6.75	7.50
32	≤ 1:12	4.00		4.00	4.00	4.00	4.25	4.25	4.25	4.50	4.75
	5:12	4.00		4.00	4.25	4.50	4.50	4.75	4.75	5.00	5.25
	7:12 ⁴	4.50		5.00	5.25	5.50	6.00	6.25	6.25	6.50	7.25
	12:12 ⁴	5.00		5.50	6.00	6.50	7.00	7.25	7.25	7.75	8.75
40	≤ 1:12	4.00		4.00	4.25	4.25	4.50	4.50	4.50	4.75	5.00
	5:12	4.00		4.25	4.50	4.75	4.75	5.00	5.00	5.25	5.50
	7:12 ⁴	4.75		5.25	5.75	6.00	6.50	7.00	7.00	7.25	8.00
	12:12 ⁴	5.50		6.00	6.50	7.25	7.75	8.25	8.25	8.75	10.00
50	≤ 1:12	4.00		4.25	4.25	4.50	4.75	4.75	4.75	5.00	5.50
	5:12	4.25		4.50	4.75	5.00	5.25	5.50	5.50	5.75	6.00
	7:12 ⁴	5.25		5.75	6.25	6.75	7.25	7.75	7.75	8.25	9.25
	12:12 ⁴	6.00		6.75	7.50	8.00	8.75	9.50	9.50	10.25	11.50
60	≤ 1:12	4.00	4.25	4.50	4.75	5.00	5.25	5.25	5.25	5.75	
	5:12	4.50	4.75	5.00	5.25	5.50	5.75	5.75	6.00	6.75	
	7:12 ⁴	5.50	6.25	6.75	7.50	8.00	8.50	8.50	9.25	10.25	
	12:12 ⁴	6.50	7.25	8.25	9.00	9.75	10.50	10.50	11.50	13.00	

For SI: 1 foot = 0.3048 m; 1 inch = 25.4 mm; 1 psf = 0.0479 kN/m²

- 1 - Table values are based on reinforcing bars with a minimum yield strength of 40,000 psi (276 MPa) and concrete with a minimum specified compressive strength of 2,500 psi (17.2 MPa).
- 2 - Table values are based on a 3.5 in (88.9 mm) thick flat wall. For a 5.5 in (139.7 mm) thick flat wall, multiply the table values by 0.9. The adjusted values shall not result in solid wall lengths less than 4 ft.
- 3 - Table values are based on a maximum unsupported wall height of 10 ft (3.0 m).
- 4 - Values are based on a 30 foot (9.1 m) building end wall width. For a 45 ft (13.7 m) building end wall and roof pitches greater than 7:12, multiply the table values by 1.2. For a 60 ft (18.3 m) building end wall and roof pitches greater than 7:12, multiply the table values by 1.4.
- 5 - Linear interpolation shall be permitted.



**Prescriptive Method - TABLE 5.2B
MINIMUM SOLID END WALL
REQUIREMENTS FOR FLAT ICF WALLS
(WIND PERPENDICULAR TO RIDGE)^{1,2,3,4,5}**

DESIGN VELOCITY PRESSURE (psf)			20	25	30	35	40	45	50	60
WALL CATEGORY	BUILDING SIDE WALL LENGTH, L (feet)	ROOF SLOPE	MINIMUM SOLID WALL LENGTH ON BUILDING END WALL (feet)							
			First Storey of Two-Storey	16	≤ 1:12	4.00	4.25	4.50	4.75	5.00
5:12	4.50	4.75			5.00	5.25	5.50	5.75	6.00	6.75
7:12 ⁴	4.50	5.00			5.25	5.75	6.00	6.25	6.75	7.25
12:12 ⁴	5.00	5.25			5.75	6.25	6.50	7.00	7.25	8.25
24	≤ 1:12	4.50		4.75	5.00	5.25	5.50	5.75	6.00	6.75
	5:12	4.75		5.25	5.50	6.00	6.25	6.75	7.00	7.75
	7:12 ⁴	5.25		5.75	6.25	6.75	7.00	7.50	8.00	9.00
	12:12 ⁴	5.50		6.25	6.75	7.25	8.00	8.50	9.00	10.25
32	≤ 1:12	4.75		5.00	5.50	5.75	6.25	6.50	6.75	7.50
	5:12	5.25		5.75	6.25	6.75	7.25	7.50	8.00	9.00
	7:12 ⁴	5.75		6.50	7.00	7.75	8.25	9.00	9.50	10.75
	12:12 ⁴	6.25		7.00	7.75	8.50	9.25	10.00	10.75	12.25
40	≤ 1:12	5.00		5.50	5.75	6.25	6.75	7.25	7.50	8.50
	5:12	5.50		6.25	6.75	7.25	8.00	8.50	9.00	10.25
	7:12 ⁴	6.25		7.00	7.75	8.75	9.50	10.25	11.00	12.50
	12:12 ⁴	7.00		8.00	8.75	9.75	10.75	11.50	12.50	14.25
50	≤ 1:12	5.50		6.00	6.50	7.00	7.50	8.00	8.50	9.50
	5:12	6.00		6.75	7.50	8.25	9.00	9.75	10.50	11.75
	7:12 ⁴	7.00		8.00	9.00	10.00	10.75	11.75	12.75	14.50
	12:12 ⁴	7.75		9.00	10.00	11.25	12.25	13.50	14.75	17.00
60	≤ 1:12	5.75		6.50	7.00	7.50	8.25	8.75	9.50	10.75
	5:12	6.75		7.50	8.25	9.25	10.00	10.75	11.75	13.25
	7:12 ⁴	7.75		9.00	10.00	11.00	12.25	13.25	14.50	16.75
	12:12 ⁴	8.75		10.00	11.50	12.75	14.00	15.50	16.75	19.50

For SI: 1 foot = 0.3048 m; 1 inch = 25.4 mm; 1 psf = 0.0479 kN/m²

- 1 - Table values are based on reinforcing bars with a minimum yield strength of 40,000 psi (276 MPa) and concrete with a minimum specified compressive strength of 2,500 psi (17.2 MPa).
- 2 - Table values are based on a 3.5 in (88.9 mm) thick flat wall. For a 5.5 in (139.7 mm) thick flat wall, multiply the table values by 0.9. The adjusted values shall not result in solid wall lengths less than 4 ft.
- 3 - Table values are based on a maximum unsupported wall height of 10 ft (3.0 m).
- 4 - Values are based on a 30 foot (9.1 m) building end wall width. For a 45 ft (13.7 m) building end wall and roof pitches greater than 7:12, multiply the table values by 1.2. For a 60 ft (18.3 m) building end wall and roof pitches greater than 7:12, multiply the table values by 1.4.
- 5 - Linear interpolation shall be permitted.



**Prescriptive Method - TABLE 5.2C
MINIMUM SOLID WALL LENGTH
REQUIREMENTS FOR FLAT ICF WALLS
(WIND PARALLEL TO RIDGE)^{1,2,3,4,5}**

DESIGN VELOCITY PRESSURE (psf)		20	25	30	35	40	45	50	60
WALL CATEGORY	BUILDING END WALL WIDTH, W (feet)	MINIMUM SOLID WALL LENGTH ON BUILDING SIDE WALL (feet)							
	One Storey of Top Storey of Two-Storey	16	4	4	4	4	4.25	4.25	4.5
24		4	4.25	4.5	4.75	4.75	5	5.25	5.5
32		4.5	4.75	5	5.25	5.5	6	6.25	6.75
40		5	5.5	5.75	6.25	6.75	7	7.5	8.25
50		5.75	6.25	7	7.5	8.25	8.75	9.5	10.75
60		6.5	7.5	8.25	9.25	10	10.75	11.75	13.25
First Storey of Two-Storey	16	4.25	4.5	4.75	5	5.25	5.5	5.75	6.5
	24	4.75	5.25	5.5	6	6.25	6.75	7	8
	32	5.5	6	6.5	7	7.5	8	8.75	9.75
	40	6.25	7	7.5	8.25	9	9.75	10.5	12
	50	7.25	8.25	9.25	10.25	11.25	12.25	13.25	15.25
	60	8.5	9.75	11	12.25	13.5	15	16.25	18.75

For SI: 1 foot = 0.3048 m; 1 inch = 25.4 mm; 1 psf = 0.0479 kN/m²

- 1 - Table values are based on reinforcing bars with a minimum yield strength of 40,000 psi (276 MPa) and concrete with a minimum specified compressive strength of 2,500 psi (17.2 MPa).
- 2 - Table values are based on a 3.5 in (88.9 mm) thick flat wall. For a 5.5 in (139.7 mm) thick flat wall, multiply the table values by 0.9. The adjusted values may not result in solid wall lengths less than 4 ft.
- 3 - Table values are based on a maximum unsupported wall height of 10 ft (3.0 m).
- 4 - Table values are based on a maximum 12:12 roof pitch.
- 5 - Linear interpolation shall be permitted.

2. Minimum amount of solid wall length for Seismic Design Categories C, D1 and D2 shall be as per table 5.5 (below).



**Prescriptive Method - TABLE 5.5
MINIMUM PERCENTAGE OF SOLID WALL LENGTH
ALONG EXTERIOR WALL LINES FOR SEISMIC DESIGN CATEGORY C AND D^{1,2}**

ICF WALL TYPE AND MINIMUM WALL THICKNESS (inches)	MINIMUM SOLID WALL LENGTH (percent)		
	ONE-STOREY OR TOP STOREY OF TWO-STOREY	WALL SUPPORTING LIGHT FRAME SECOND STOREY AND ROOF	WALL SUPPORTING ICF SECOND STOREY AND ROOF
Seismic Design Category C ³	20 percent	25 percent	35 percent
Seismic Design Category D1 ⁴	25 percent	30 percent	40 percent
Seismic Design Category D2 ⁴	30 percent	35 percent	45 percent

For SI: 1 inch = 25.4 mm; 1 mph = 1.6093 km/hr

- 1 - Base percentages are applicable for maximum unsupported wall height of 10-feet (3.0-m), light-frame gable construction, all ICF wall types in Seismic Design Category C, and all ICF wall types with a nominal thickness greater than 5.5 inches (140 mm) for Seismic Design Category D1 and D2. These percentages assume that the maximum weight of the interior and exterior wall finishes applied to ICF walls do not exceed 8 psf (0.38 KN/m³)
- 2 - For all walls, the minimum required length of solid walls shall be based on the table percent value multiplied by the minimum dimensions of a rectangle inscribing the overall building plan.
- 3 - Walls shall be reinforced with minimum No.5 rebar (grade 40 or 60) spaced a maximum of 24 inches (609.6 mm) on center each way or No.4 rebar (Grade 40 or 60) spaced at a maximum of 16 inches (406.4 mm) on center each way.
- 4 - Walls shall be constructed with a minimum concrete compressive strength of 3,000 psi (20.7 Mpa) and reinforced with minimum #5 rebar (Grade 60, ASTM A706) spaced a maximum of 18 inches (457.2 mm) on center each way or No. 4 rebar (Grade 60, ASTM A706) spaced at a maximum of 12 inches (304.8 mm) on center each way.

3. The larger amount of solid wall length as required by tables 5.2A, 5.2B, 5.2C and 5.5 shall be used.



6.2.1.6 – Floor Joist Connections

[Prescriptive Method – 6.2.2]

1. Wood ledger board shall be anchored to flat ICF walls in accordance with table 6.1 (below).

**Prescriptive Method - TABLE 6.1
FLOOR LEDGER-ICF WALL CONNECTION (SIDE-BEARING CONNECTION)
REQUIREMENTS^{1,2,3}**

MAXIMUM FLOOR CLEAR SPAN ⁴ (feet)	MAXIMUM ANCHOR BOLT SPACING ⁵ (inches)			
	STAGGERED 1/2 INCH DIAMETER ANCHOR BOLTS	STAGGERED 5/8 INCH DIAMETER ANCHOR BOLTS	TWO 1/2 INCH DIAMETER ANCHOR BOLTS ⁶	TWO 5/8 INCH DIAMETER ANCHOR BOLTS ⁶
8	18	20	36	40
10	16	18	32	36
12	14	18	28	36
14	12	16	24	32
16	10	14	20	28
18	9	13	18	26
20	8	11	16	22
22	7	10	14	20
24	7	9	14	18
26	6	9	12	18
28	6	8	12	16
30	5	8	10	16
32	5	7	10	14

For SI: 1 foot = 0.3048 m; 1 inch = 25.4 mm

- 1 - Minimum ledger board nominal depth shall be 8 inches (203 mm). The actual thickness of the ledger board shall be a minimum of 1.5 inches (38 mm). Ledger board shall be minimum No. 2 Grade.
- 2 - Minimum edge distance shall be 2 inches (51 mm) for 1/2-inch-(13-mm-) diameter anchor bolts and 2.5 inches (64 mm) for 5/8-inch-(16-mm) diameter anchor bolts.
- 3 - Interpolation is permitted between floor spans.
- 4 - Floor span corresponds to the clear span of the floor structure (i.e., joists or trusses) spanning between load-bearing walls or beams.
- 5 - Anchor bolts shall extend through the ledger to the center of the flat ICF wall thickness or the center of the horizontal or vertical core thickness of the waffle-grid or screen-grid ICF wall system.
- 6 - Minimum vertical clear distance between bolts shall be 1.5 inches (38 mm) for 1/2-inch-(13-mm-) diameter anchor bolts and 2 inches (51 mm) for 5/8-inch-(16 mm) diameter anchor bolt

2. Please refer to Prescriptive Method Section 6 for additional requirements on floor, roof, and minimum wall thickness requirements for high wind pressures and seismic design categories C, D1 and D2.



Part 7 – Approvals & Evaluations

7.1 – Amvic ICF – Technical Testing

USA		
Expanded Polystyrene in accordance with ICBO ES AC12 "Acceptance Criteria for Foam Plastic Insulation" in Conjunction with ASTM C578-95	Requirement	Amvic Results
1 - Expanded Polystyrene Testing ASTM C578-95		
Density (ASTM C 1622-98)	1.35 lbs/ft ³	1.5 lbs/ft ³
Thermal Resistance (ASTM C 177-97)	4.0 F.ft ² .h/Btu	4.0 F.ft ² .h/Btu
Compressive Strength (ASTM D 1621-94)	15.0 psi	19.8 psi
Flexural Strength (ASTM C 203-99)	40.0 psi min.	42.57 psi
Water Vapor Permeance (ASTM E 96-94)	200 max ng/Pa.s. s ²	130.1 ng/Pa.s. s ²
Water Absorption (ASTM C272-91)	3.0% by vol max	2.95%
Dimensional Stability (ASTM D 2126-94)	2.0% max	0.52%
Limiting Oxygen Index (ASTM D 2863-97)	24% min	37%
Trueness and Squareness (ASTM C 550-95)		
Edge Trueness	0.03125 in/ft max	0.0197 in/ft
Face Trueness	0.03125 in/ft max	0.0197 in/ft
Length and Width Squareness	0.0625 in/ft max	0.0295 in/ft
2 - Plastic Tie Testing ICBO ES AC116		
Fastener Withdrawal (ASTM D1761-99)	N/A	39.61 lbs Safety Factor of 5
Fastener Shear Strength (ASTM D1761-99)	N/A	60.22 lbs Safety Factor of 3.2
Tensile Strength (ASTM D638-99)	N/A	810 lbs at Ambient Temperature
3 - Fire Testing		
Room Fire Test (UBC 1997 26-3)	N/A	Passed/Complied
Other Testing		
A - Flammability ASTM E 84		
Flame Spread	25 max	25 or less
Smoke Developed	450 max	450 or less
B - Fire Burning Characteristics of Plastic Ties		
Ignition Temperature (ASTM D1929-68 (1975)	329 (C) 650 (F) min	400 (C) 752 (F)
Burn Rate (ASTM D635-98)	40 mm/min max	20.2 mm/min
Smoke Density (ASTM D2843-93)	75%	25.80%

CANADA		
Expanded Polystyrene in Accordance with Canadian Construction Material Center (CCMC) Technical Guide for "Modular Expanded - Polystyrene Concrete Forms" Master Format Section 03131 "		
1 - Expanded Polystyrene Testing CAN/ULC S701-97, Type II		
Thermal Resistance (ASTM C177-97)	0.7 m ² .OC/W min	0.7 m ²
Water Vapor Permeance (ASTM E 96-94)	200 Ng/Pa.s. s ² max	130.1 Ng/Pa.s. s ² max
Dimensional Stability (ASTM D 2126-94)	1.5% max	0.52%
Flexural Strength (ASTM C 203-99)	240 KPa min	314.6 KPa
Water Absorption (ASTM D2842-97)	4.0% by vol max	0.93%
Compressive Strength (ASTM D 1621-94)	110 KPa min	136.5 Kpa
Limiting Oxygen Index (ASTM D 2863-97)	24% min	37%
2 - Plastic Web Testing CCMC Technical Guide		
Tensile Strength (ASTM D638-99)	N/A	810 lbs
Fastener Withdrawal (ASTM D1761-99)	N/A	198.04 lbs
Fastener Shear Strength (ASTM D1761-99)	N/A	226.08 lbs
3 - Forming Capacity Test section 6.4.4 of CCMC Technical Guide for Modular Expanded Polystyrene		
Forming Capacity	40 KPa (835 lbs/ft ²)	41.4 Kpa (865 lbs/ft ²)
Other Testing		
1 - Flammability CAN.4-S102.2		
Flame Spread	N/A	210
Smoke Developed	N/A	400-450
CANADA & USA		
1 - Fire Resistance Rating CAN/ULC S101-M89 and ASTM E119		
6 in wall with Drywall	N/A	3 hrs +
2 - 15 Minute Stay in Place Fire Test CAN/ULC S101-04 and ASTM E119-00a		
6 in wall with drywall	N/A	Passed/Complied



7.2 – List of Code Approvals

Code Approvals

Major Code Approvals

ICC-ESR 1269 - http://www.icc-es.org/reports/pdf_files/ICC-ES/1269.pdf



CCMC 13043-R - http://irc.nrc-cnrc.gc.ca/ccmc/registry/03/13043_e.pdf



Local/Regional Code Approvals

Bahamas Ministry of Works & Utilities. Report# MOW&U/BC/24/14

City of Los Angeles, CA. Report #25477

Ontario Ministry of Municipal Affairs & Housing, Report # 02-02-89

State of Florida

State of Wisconsin





**National Research
Council Canada**

Institute for
Research in
Construction

**Conseil national
de recherches Canada**

Institut de
recherche en
construction

CCM 13043-R

CCMC

*EVALUATION
REPORT*

DIVISION 03131

Issued 2001-10-23

Re-evaluated 2005-12-14

Revised 2006-01-17

Re-evaluation due 2007-10-23

Amvic Building System

Amvic Inc.
501 McNicoll Avenue
Toronto, Ontario
M2H 2E2

Tel.: (416) 410-5674
Fax: (416) 759-7402

Plant: 501 McNicoll Avenue
Toronto, Ontario

*This Report is provided without representation, warranty, or guarantee of any kind, expressed or implied, and the National Research Council of Canada (NRC) provides no endorsement for any evaluated material, product, system or service described herein.
NRC has evaluated the material, product, system or service described herein only for those characteristics stated herein. The information and opinions in this Report are directed to those who have the appropriate degree of experience to use and apply its contents.
NRC accepts no responsibility whatsoever arising in any way from any and all use or reliance on the information contained in this Report. NRC is not undertaking to render professional or other services for or on behalf of any person or entity nor to perform any duty owed by any person or entity to another person or entity.*

1. Purpose of Evaluation

The proponent sought confirmation from the Canadian Construction Materials Centre (CCMC) that the “Amvic Building System” can serve as a wall forming system, resulting in a monolithic concrete wall in compliance with the intent of the National Building Code of Canada (NBC) 1995.

2. Opinion

Subject to the limitations and conditions stated in this report, test results and assessments provided by the proponent show that the “Amvic Building System” complies with CCMC’s Technical Guide for Modular, Expanded-polystyrene or Polyurethane Concrete Forms, Masterformat number 03131, dated 2000-09-16, and provides a level of performance equivalent to that required in:

- NBC 1995, Article 4.3.3.1, Subsection 9.3.1, Section 9.4, and Subsection 9.15.4 with respect to wall construction.



Ruling No. 02-02-89 (13043-R) authorizing the use of this product in Ontario, subject to the terms and conditions contained in the Ruling, was made by the Minister of Municipal Affairs and Housing on September 6, 2002 pursuant to s.29 of the Building Code Act, 1992 (see Ruling for terms and conditions).

Canada Mortgage and Housing Corporation permits the use of this product in construction financed or insured under the National Housing Act.

Note: The attachment of exterior cladding and interior finishing materials has not been assessed by the present evaluation.

3. Description

The “Amvic Building System” is a modular, interlocking, concrete form system consisting of two expanded-polystyrene panels with polypropylene connectors molded into the polystyrene panels and equally spaced at 150 mm horizontally and 200 mm vertically. The extremities of the polypropylene connectors are embedded close to the exterior surface of the polystyrene panels.

The units have a preformed symmetrical interlocking design along their top, bottom and side edges that makes the forms reversible (top and bottom, left and right), and that facilitates stacking and alignment and prevents leakage of freshly-placed concrete.

The units are dry-laid and stacked in a running (staggered) configuration. The stacked units form a rectangular space that, after being filled with concrete, results in an insulated, monolithic concrete wall of uniform thickness.

Reinforcement may be placed where required to satisfy strength requirements for above- or below-grade loadbearing walls, beams, lintels and shear walls.

The units have external dimensions of 1213 mm in length and 406 mm in height. The polystyrene panels are 64 mm thick, resulting in an overall wall thickness of 228 mm, 278 mm, 328 mm and 378 mm that in turn, encloses a

100 mm, 150 mm, 200 mm and 250 mm concrete wall.

“Amvic Building System” forms are available in straight, 90-degree, 45-degree corner forms, tapered top and brickledge forms.

“Amvic Building System” standard form is illustrated in Figure 1.

Typical details for residential construction are shown in Figures 2, and 3, 4, 5, 6 and 7.

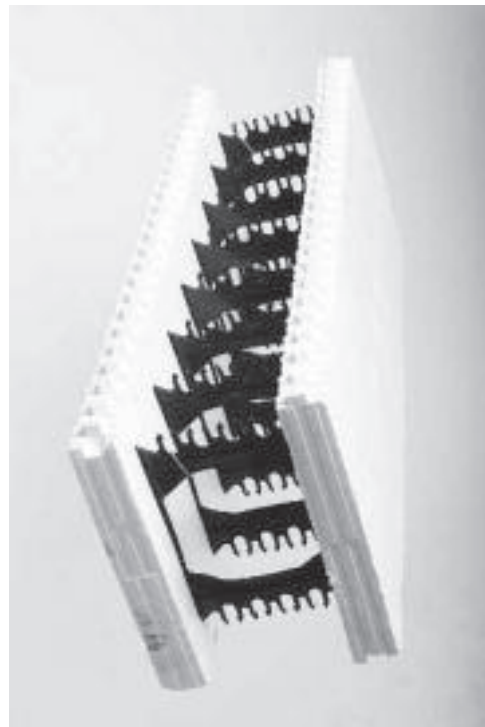

Figure 1. “Amvic Building System” Standard Unit



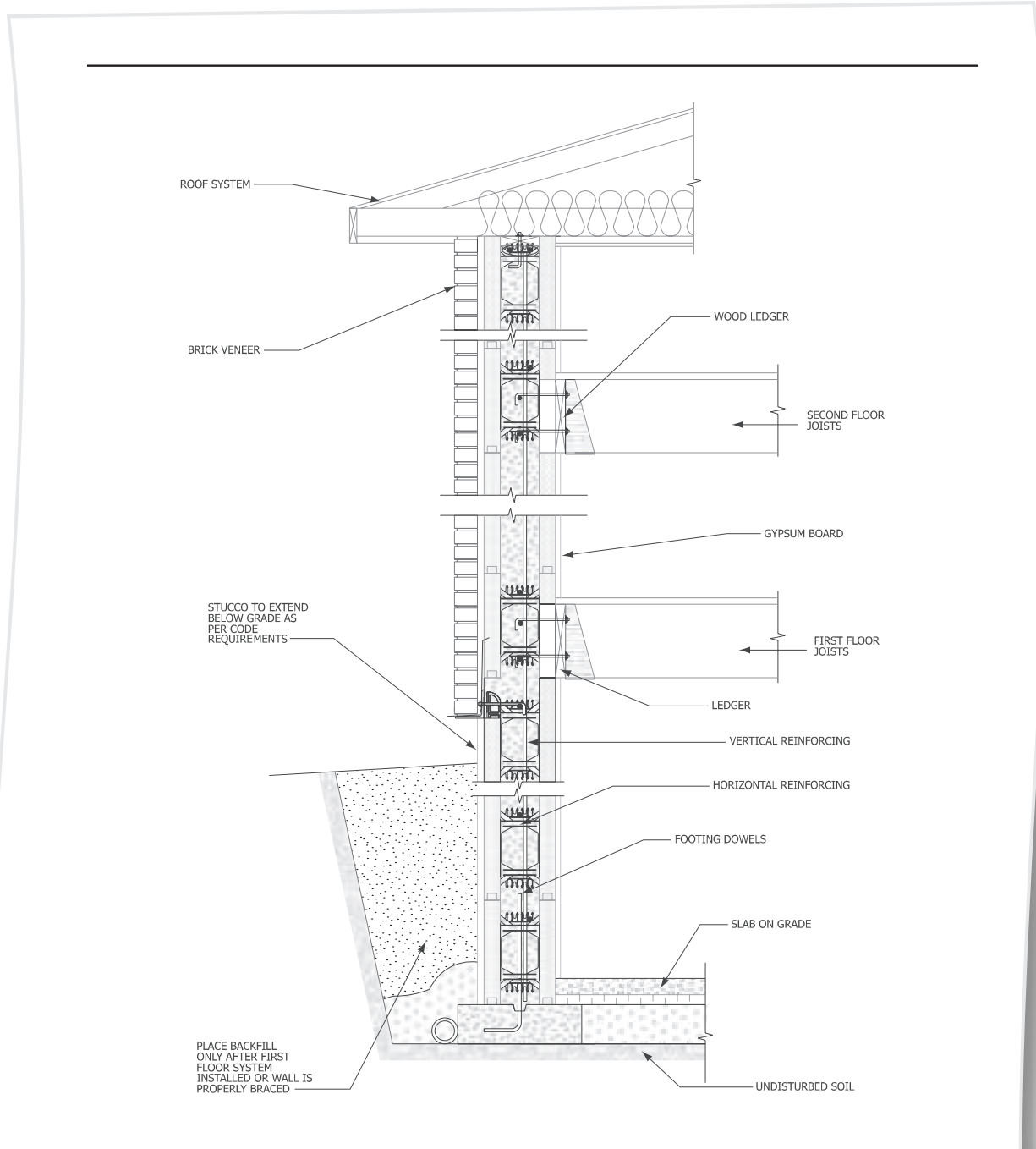

Figure 2. “Amvic Building System” Wall Section, Basement + Two Storey



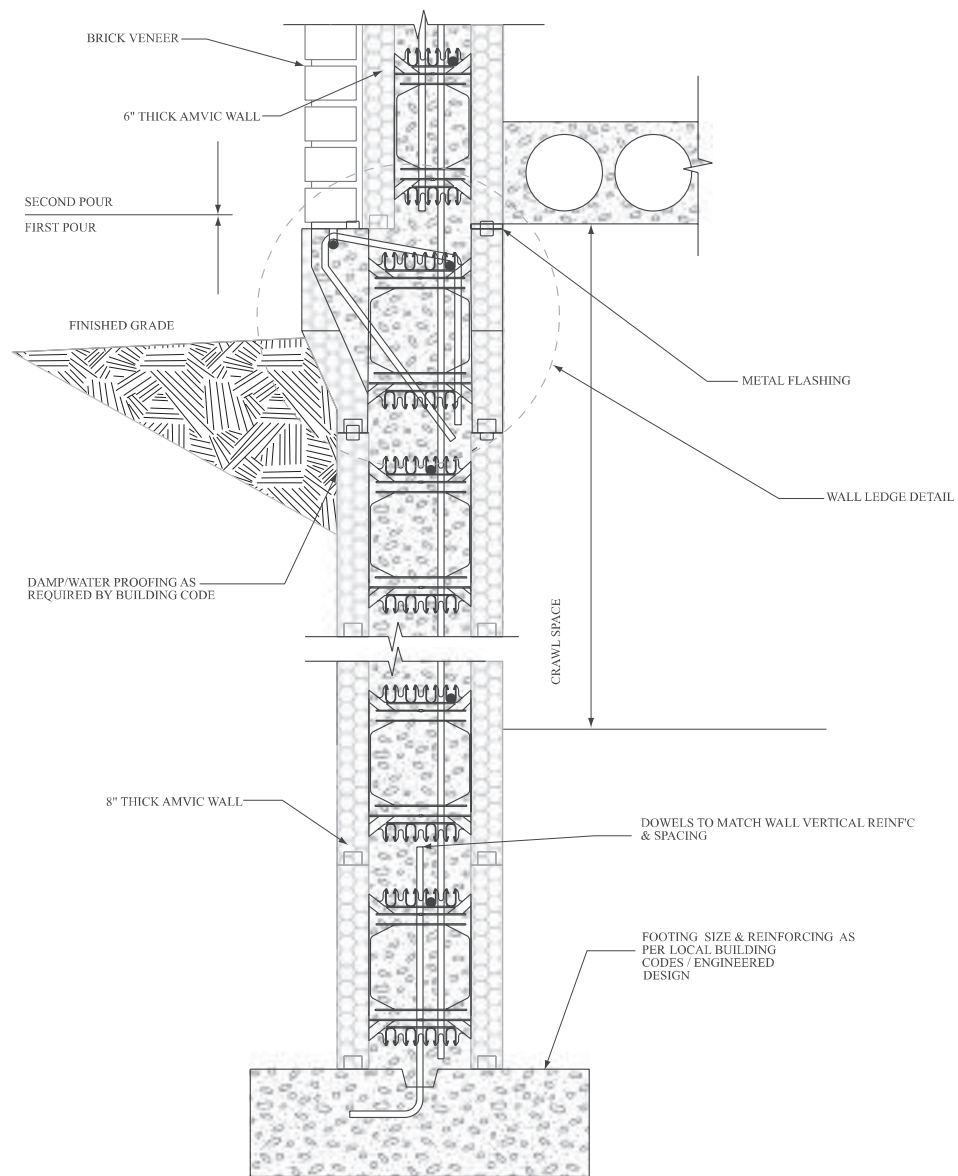

Figure 3. "Amvic Building System: 200 mm Foundation Wall to 150 mm Above-grade Wall Brick Veneer Ledge Detail



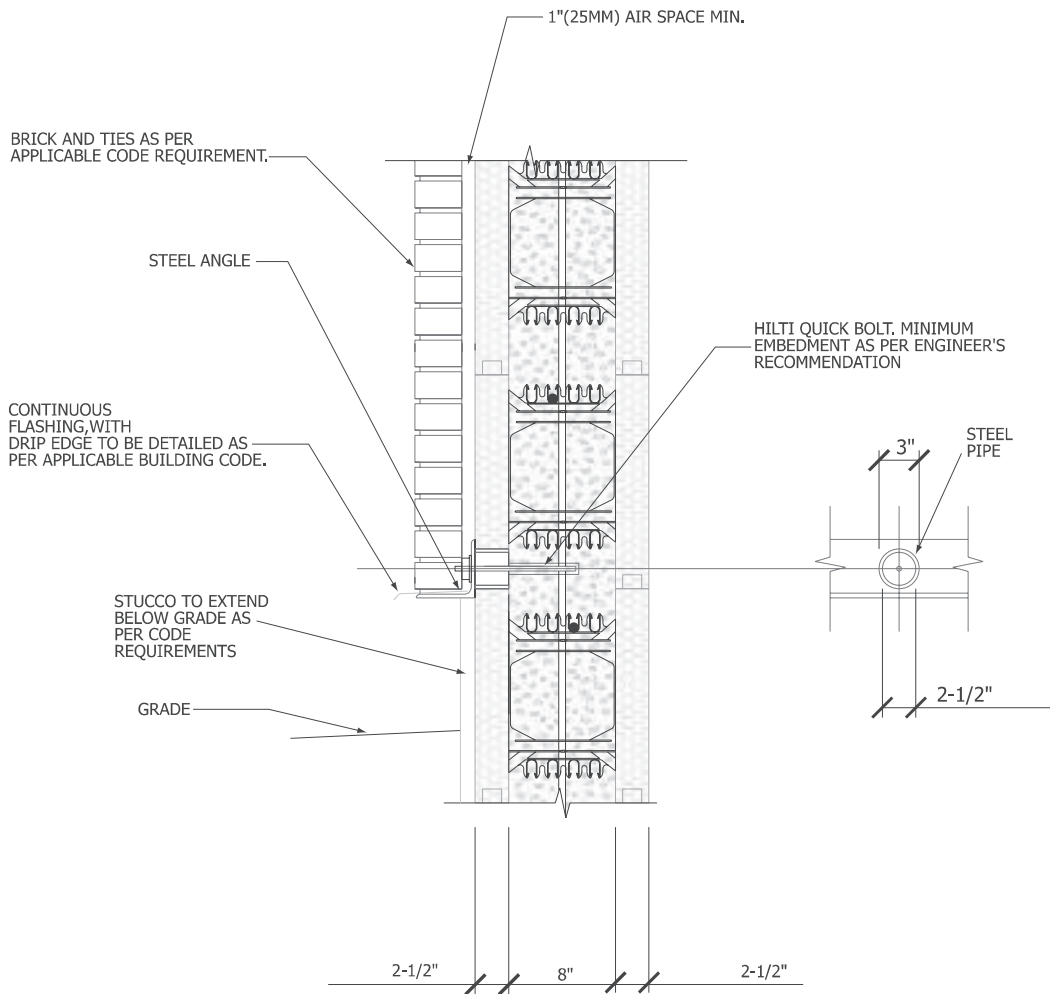

Figure 4. "Amvic Building System" Brick Support Angle Detail



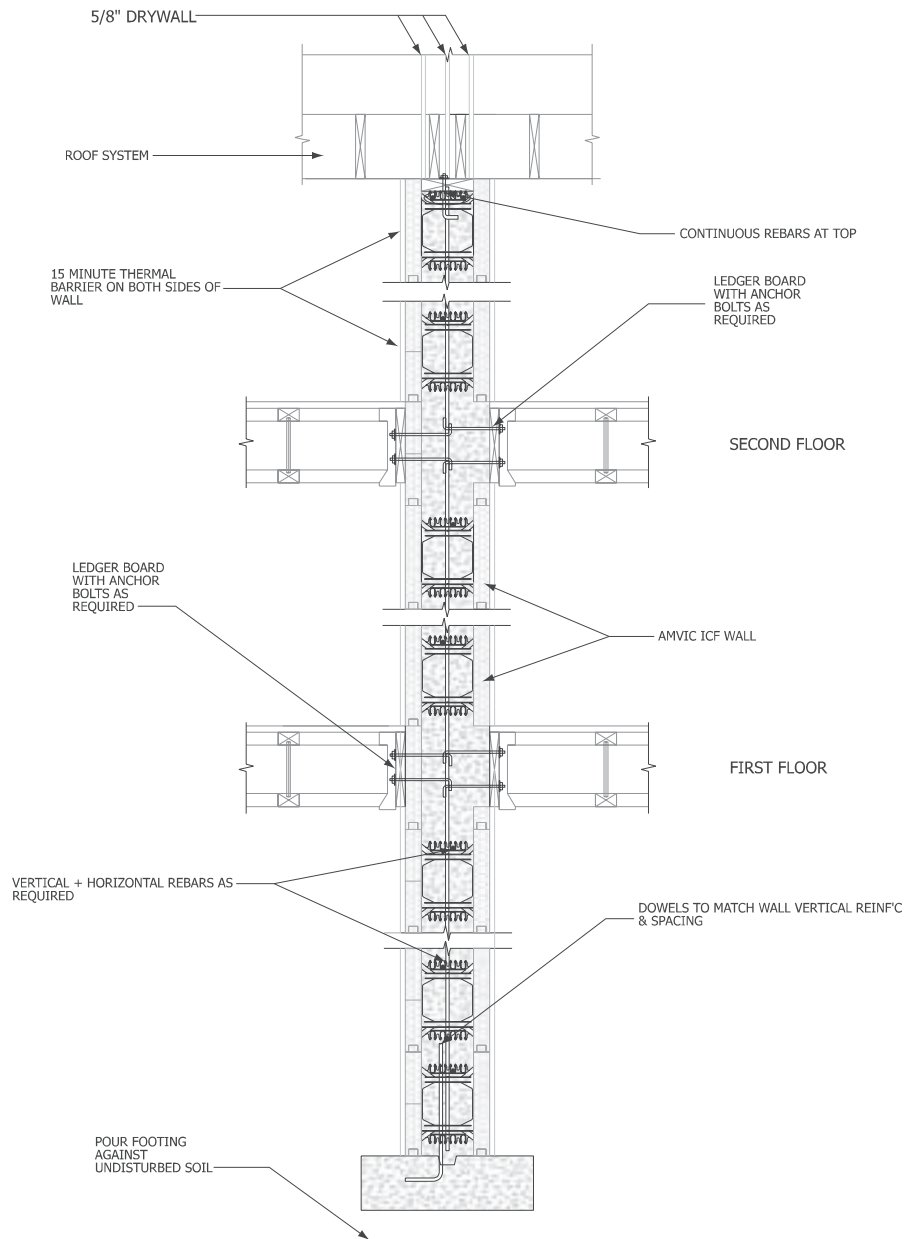

Figure 5. “Amvic Building System” Party Wall Detail



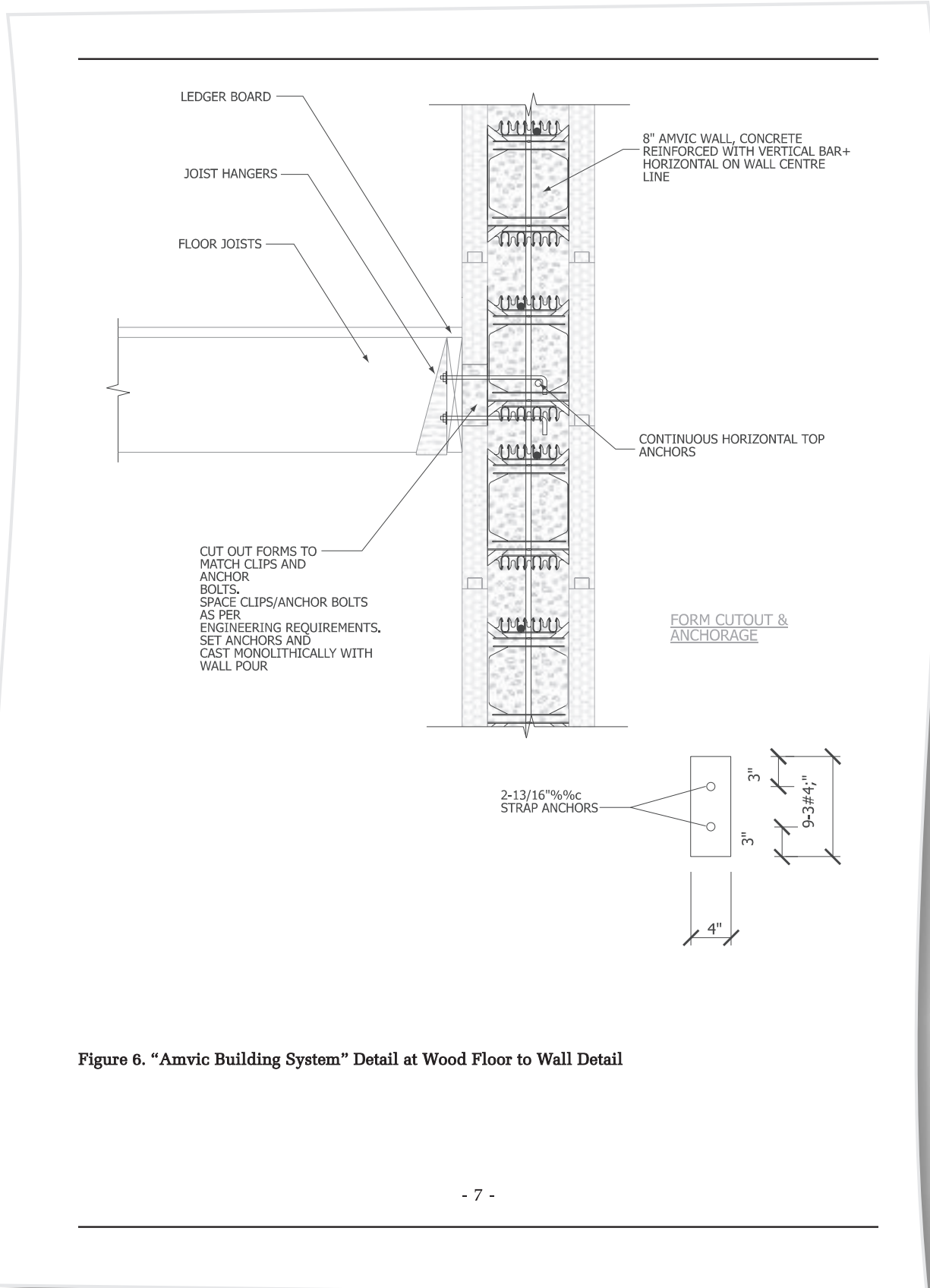

Figure 6. "Amvic Building System" Detail at Wood Floor to Wall Detail



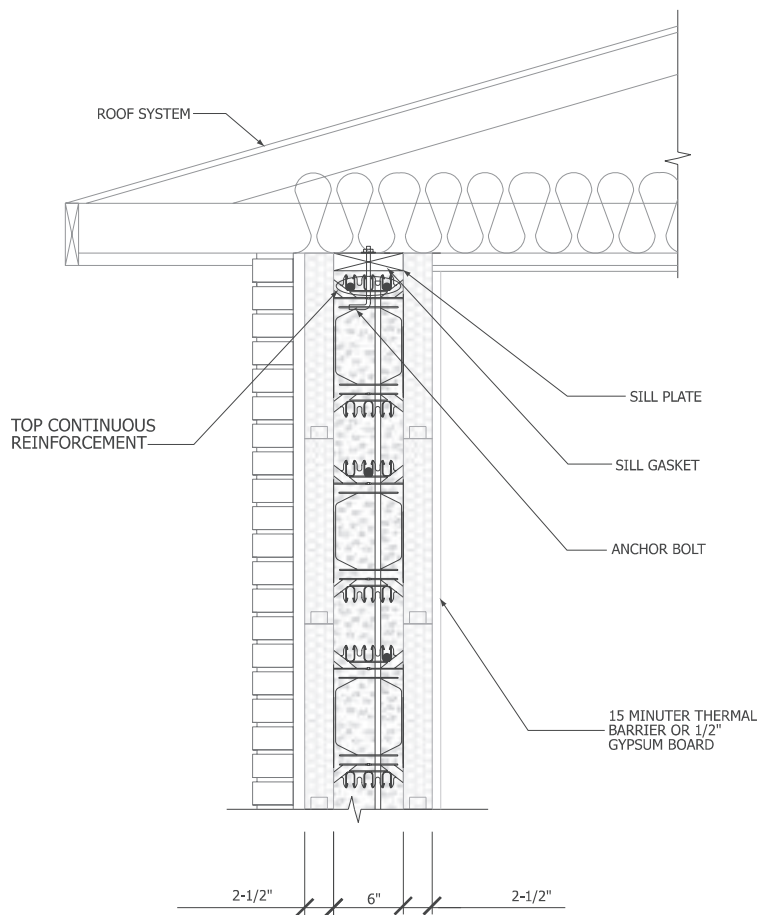

Figure 7. "Amvic Building System" Wall/Roof Connection Detail

4. Usage and Limitations

The use of "Amvic Building System" is permitted in the construction of houses and small buildings up to two storeys high that fall under the provisions of Part 9 of the NBC 1995, subject to the following conditions:

- The structural applications of "Amvic Building System" must be in strict accordance with the design analysis as prepared for Amvic Inc., Report No. 050710.1, dated 26 September 2005,

from which tables 1(a), 1(b), 2(a), 2(b), 2(c) and 2(d) have been reproduced.

- The concrete used in "Amvic Building System" must be Type 10 or Type 30 having a minimum compressive strength of 20 MPa and a maximum slump of 140 ± 25 mm.
- For the wall heights indicated in tables 2(a) and 2(b), the pouring of concrete must be made at a rate of 1.3 m per hour in consecutive



lifts; each lift is limited to a maximum height of 1.3 m.

- The EPS insulation used in this system must comply with CAN/ULC-S701-97, “Standard For Thermal Insulation, Polystyrene, Boards and Pipe Covering”, Type 2.
- The aging of “Amvic Building System” EPS insulation panels must be not less than four weeks from the date of manufacturing.
- The interior face of “Amvic Building System” panels shall be protected from the inside of the building in accordance with Sentence 9.10.16.10.(1) of the NBC 1995.
- For above-grade installations, the exterior face of the “Amvic Building System” shall be protected with materials conforming to the NBC 1995, Sections 9.20., 9.27. and/or 9.28.
- For foundation-wall installations, the backfill shall be placed in such a way as to avoid damaging the wall, the exterior insulation panel, and the waterproofing and dampproofing protection.
- The concrete must be cured a minimum of seven days before backfilling. The top of the foundation wall must be supported by the first floor prior to backfilling.
- For below-grade installations, dampproofing material compatible with the EPS insulation must be provided in accordance with the NBC 1995, Article 9.13.1.1.
- Where hydrostatic pressure exists, waterproofing compatible with the EPS insulation must be provided in accordance with the NBC 1995, Article 9.13.1.2.

- The backfill material must be well-drained and a drainage system must be installed around the footing in accordance with NBC requirements.
- Installation of the “Amvic Building System” shall be in strict compliance with the “Amvic Technical Manual”, dated 15 August 2001. Only installers who have been trained and authorized by Amvic Inc. shall be contracted to set up the wall system.

5. Performance

Compliance of the expanded polystyrene thermal insulation with the requirements of CAN/ULC-S7901-97 is covered under Intertek Testing Services NA LTD. certification program.

The design analysis of walls using the “Amvic Building System”, as prepared for “Amvic Inc.”, is summarized in tables 1(a), 1(b), 2(a), 2(b), 2(c) and 2(d).

The tables provide steel reinforcement designs for a number of different wall and lintel applications based on the structural loads, and the design assumptions are indicated below each table. When the “Amvic Building System” is used in structural applications outside the scope of the referenced design analysis, a registered professional engineer skilled in concrete design must certify the design analysis and the design drawings for such applications. The engineer shall certify that the construction provides a level of performance equivalent to that required by Part 4 and/or Part 9 of the NBC 1995.



Table 1(a) – Vertical & Horizontal Steel Reinforcement for “Amvic Building System” Below-grade Walls in all Seismic Zones⁽¹⁾

Wall Height (m)	Backfill Height (m)	Max. Spacing for Vertical Reinforcement				Max. Spacing for Horizontal Reinforcement			
		100 mm Wall	150 mm Wall	200 mm Wall	250 mm Wall	100 mm Wall	150 mm Wall	200 mm Wall	250 mm Wall
2.44	2.135	10M@300	10M@300	10M@300	15M@450	15M@400	15M@400	15M@400	15M@400
	1.830	10M@300	10M@300	10M@300	15M@450	15M@400	15M@400	15M@400	15M@400
	1.525	10M@300	10M@300	10M@300	15M@450	10M@200	15M@400	15M@400	15M@400
	1.220	10M@300	10M@300	10M@300	15M@450	10M@200	15M@400	15M@400	15M@400
3.05	2.754	15M@150	15M@450	15M@450	15M@450	15M@400	15M@400	15M@400	15M@400
	2.440	10M@150	10M@300	10M@300	15M@450	15M@400	15M@400	15M@400	15M@400
	2.135	15M@450	10M@300	10M@300	15M@450	15M@400	15M@400	15M@400	15M@400
	1.830	10M@300	10M@300	10M@300	15M@450	15M@400	15M@400	15M@400	15M@400
3.66	1.525	10M@150	10M@300	10M@400	15M@450	10M@200	15M@400	15M@400	15M@400
	1.220	10M@300	10M@300	10M@300	15M@450	10M@200	15M@400	15M@400	15M@400
	3.355		15M@150	10M@150	10M@150		15M@400	15M@400	15M@400
	3.050		10M@150	10M@150	10M@150		15M@400	15M@400	15M@400
3.66	2.745		10M@150	10M@150	10M@150		15m@400	15m@400	15m@400
	2.440		15m@450	15m@450	15m@450		15m@400	15m@400	15m@400
	2.135	10m@150	10m@300	10m@300	15m@450	15m@400	15m@400	15m@400	15m@400
	1.830	10m@300	10m@300	10m@300	15m@450	15m@400	15m@400	15m@400	15m@400
3.66	1.525	10m@150	10m@300	10m@300	15m@450	10m@200	15m@400	15m@400	15m@400
	1.220	10m@300	10m@300	10m@300	15m@450	10m@200	15m@400	15m@400	15m@400

Note: The shaded area means not feasible with respect to the proposed backfill height.

Note to Table 1(a):

(1) Table 1(a) is based on the following assumptions:

- Loads include earth pressure and surcharge loads, plus gravity load. Gravity load assumes two storeys, concrete construction and wood-frame roof structure.
- Wall height taken is 3.04 m and snow load is equal to 1.9 kPa.
- Applicable to all seismic zones.
- Specified compressive strength of concrete, f_c at 28 days is 20 MPa.
- Specified yield strength of reinforcement, f_y , is 400 MPa.
- Two #15 bars should be placed around all openings and shall extend at least 600 mm beyond each corner of the opening.



Table 1(b) – Vertical/Horizontal Steel Reinforcement for “Amvic Building System” Above-grade Walls in all Seismic Zones⁽¹⁾

Wall Height (m)	Max. Spacing of Vertical Reinforcement (mm)					Max. Spacing for Horizontal Reinforcement (mm)				
	100 mm Wall	150 mm Wall	200 mm Wall	250 mm Wall	100 mm Wall	150 mm Wall	200 mm Wall	250 mm Wall		
Single-Storey concrete construction supporting a wood-frame roof structure										
2.44	10M@300	10M@450	10M@300	15M@450	10M@200	10M@200	10M@200	10M@200	15M@400	15M@400
3.05	10M@300	10M@450	10M@300	15M@450	10M@200	10M@200	10M@200	10M@200	15M@400	15M@400
3.66	10M@300	10M@450	10M@300	15M@450	10M@200	10M@200	10M@200	10M@200	15M@400	15M@400
Ground floor concrete construction supporting a second-storey wood frame and wood-frame roof structures										
2.44	10M@300	10M@450	10M@300	15M@450	10M@200	10M@200	10M@200	10M@200	15M@400	15M@400
3.05	10M@300	10M@450	10M@300	15M@450	10M@200	10M@200	10M@200	10M@200	15m@400	15m@400
3.66	10m@300	10m@450	10m@300	15m@450	10m@200	10m@200	10m@200	10m@200	15m@400	15m@400
Ground floor construction supporting a second-storey concrete construction and a wood-frame roof structure										
2.44	10M@300	10M@450	10M@300	15M@450	10M@200	10M@200	10M@200	10M@200	15M@400	15M@400
3.05	10M@300	10M@450	10M@300	15M@450	10M@200	10M@200	10M@200	10M@200	15m@400	15m@400
3.66	10m@300	10m@450	10m@300	15m@450	10m@200	10m@200	10m@200	10m@200	15m@400	15m@400

Note to Table 1(b):

(1) Table 1(b) is based on the following assumptions:

- Loads include all applicable gravity and wind loads.
- Applicable to all seismic zones and to a maximum factored wind pressure of 3.15 kPa.
- Specified compressive strength of concrete, f_c , at 28 days is 20 MPa.
- Specified yield strength of reinforcement, f_y , is 400 MPa.
- Two #15 bars should be placed around all openings and shall extend at least 600 mm beyond each corner of the opening.



Table 2(a) – Minimum Steel Reinforcement of Lintels for 250 mm Core “Amvic Building System”

Opening Width mm (ft)	Factored Uniformly Distributed Load (nK/m)													
	2.0		5.0		10.0		15.0		20.0		25.0		30.0	
	Bottom Steel	Stirrup End Dist. (mm)	Bottom Steel	Stirrup End Dist. (mm)	Bottom Steel	Stirrup End Dist. (mm)	Bottom Steel	Stirrup End Dist. (mm)	Bottom Steel	Stirrup End Dist. (mm)	Bottom Steel	Stirrup End Dist. (mm)	Bottom Steel	Stirrup End Dist. (mm)
1000	1-15M	0	1-15M	0	1-15M	0	1-15M	0	1-15M	0	1-15M	0	1-15M	0
1500	1-15M	0	1-15M	0	1-15M	0	1-15M	0	1-15M	0	1-15M	0	1-15M	0
2000	1-15M	0	1-15M	0	1-15M	0	1-15M	0	1-15M	0	1-15M	77	1-15M	231
2500	1-15M	0	1-15M	0	1-15M	0	1-15M	0	1-15M	96	1-15M	327	1-20M	481
3000	1-15M	0	1-15M	0	1-15M	0	1-15M	0	1-15M	346	1-20M	577	1-20M	731
3500	1-15M	0	1-15M	0	1-15M	0	1-15M	212	1-20M	596	2-15M	827	1-25M	981
4000	1-15M	0	1-15M	0	1-15M	0	1-20M	4624	2-15M	846	1-25M	1077	2-20M	1231
4500	1-15M	0	1-15M	0	1-20M	0	2-15M	712	1-25M	1096	2-20M	1327	2-25M	1481
5000	1-15M	0	1-15M	0	1-20M	193	1-25M	962	2-20M	1346	2-25M	1577	2-25M	1731

Note to Tables 2(a), 2(b) and 2(c):

(1) Tables 2(a), 2(b) and 2(c) are based on the following assumptions:

- The factored uniformly distributed load includes live and dead loads.
- The minimum height of the lintel is 406 mm.
- Stirrups are single leg fabricated from #10 bars spaced at 170 mm on centre.
- Lintel reinforcing is located in bottom of lintel and projects 205 mm into lintel support on each side.
- Specified compressive strength of concrete, @ 28 days f'_c is 20 MPa.



Table 2(b) – Minimum Steel Reinforcement of Lintels for 200 mm Core “Amvic Building System”

Opening Width mm (ft)	Factored Uniformly Distributed Load (nK/m)													
	2.0		5.0		10.0		15.0		20.0		25.0		30.0	
	Bottom Steel	Stirrup End Dist. (mm)	Bottom Steel	Stirrup End Dist. (mm)	Bottom Steel	Stirrup End Dist. (mm)	Bottom Steel	Stirrup End Dist. (mm)	Bottom Steel	Stirrup End Dist. (mm)	Bottom Steel	Stirrup End Dist. (mm)	Bottom Steel	Stirrup End Dist. (mm)
1000	1-15M	0	1-15M	0	1-15M	0	1-15M	0	1-15M	0	1-15M	0	1-15M	0
1500	1-15M	0	1-15M	0	1-15M	0	1-15M	0	1-15M	0	1-15M	12	1-15M	135
2000	1-15M	0	1-15M	0	1-15M	0	1-15M	0	1-15M	78	1-15M	262	1-15M	385
2500	1-15M	0	1-15M	0	1-15M	0	1-15M	21	1-15M	328	1-15M	512	1-20M	635
3000	1-15M	0	1-15M	0	1-15M	0	1-15M	271	1-15M	578	1-20M	762	2-15M	885
3500	1-15M	0	1-15M	0	1-15M	0	1-15M	521	1-20M	828	2-15M	1012	1-25M	1135
4000	1-15M	0	1-15M	0	1-15M	156	1-20M	771	2-15M	1078	1-25M	1262	2-20M	1385
4500	1-15M	0	1-15M	0	1-20M	406	2-15M	1021	1-25M	1328	1-30M	1512	2-25M	1635
5000	1-15M	0	1-15M	0	1-20M	193	1-25M	1271	1-30M	1578	2-25M	1762	2-25M	1885

Table 2(c) – Minimum Steel Reinforcement of Lintels for 150 mm Core “Amvic Building System”

Opening Width mm (ft)	Factored Uniformly Distributed Load (nK/m)													
	2.0		5.0		10.0		15.0		20.0		25.0		30.0	
	Bottom Steel	Stirrup End Dist. (mm)	Bottom Steel	Stirrup End Dist. (mm)	Bottom Steel	Stirrup End Dist. (mm)	Bottom Steel	Stirrup End Dist. (mm)	Bottom Steel	Stirrup End Dist. (mm)	Bottom Steel	Stirrup End Dist. (mm)	Bottom Steel	Stirrup End Dist. (mm)
1000	1-15M	0	1-15M	0	1-15M	0	1-15M	0	1-15M	0	1-15M	0	1-15M	40
1500	1-15M	0	1-15M	0	1-15M	0	1-15M	0	1-15M	60	1-15M	198	1-15M	290
2000	1-15M	0	1-15M	0	1-15M	0	1-15M	80	1-15M	310	1-15M	448	1-15M	540
2500	1-15M	0	1-15M	0	1-15M	119	1-15M	330	1-15M	560	1-15M	698	1-20M	790
3000	1-15M	0	1-15M	0	1-15M	369	1-20M	580	1-15M	810	1-20M	948	2-15M	1040
3500	1-15M	0	1-15M	0	1-15M	619	1-20M	830	1-20M	1060	1-25M	1198	1-25M	1290
4000	1-15M	0	1-15M	0	1-15M	869	1-20M	1080	2-15M	1310	1-25M	1448		
4500	1-15M	0	1-15M	0	1-20M	1119	2-15M	1330	2-20M	1560				
5000	1-15M	0	1-15M	0	1-20M	1119	1-25M	1580						



Table 2(d) – Minimum Steel Reinforcement of Lintels for 100 mm Core “Amvic Building System”

Opening Width (mm)	Factored Uniformly Distributed Load (kN/m)							
	2.0		5.0		10.0		15.0	
	Bottom Steel	Stirrup End Dist. (mm)	Bottom Steel	Stirrup End Dist. (mm)	Bottom Steel	Stirrup End Dist. (mm)	Bottom Steel	Stirrup End Dist. (mm)
1000	1-10M	0	1-10M	0	1-10M	0	1-10M	0
1500	1-10M	0	1-10M	0	1-10M	0		
2000	1-10M	0	1-10M	0				
2500	1-10M	0	1-10M	0				
3000	1-10M	0	1-10M	0				
3500	1-10M	0	1-10M	0				
4000	1-10M	0						
4500	1-10M	0						
5000	1-10M	0						

For more information contact:

Fadi Nabham
(613) 993-7702

*Issued by the Institute for Research in Construction
under the authority of the National Research Council*

John Flack, Ph.D.
Manager, CCMC

Note: Readers are asked to refer to limitations imposed by NRC on the interpretation and use of this report. These limitations are included in the introduction to CCMC's Registry of Product Evaluations, of which this report is part.

Readers are advised to confirm that this report has not been withdrawn or superseded by a later issue by referring to <http://irc.nrc.gc.ca/ccmc>, or contacting the Canadian Construction Materials Centre, Institute for Research in Construction, National Research Council of Canada, Montreal Road, Ottawa, Ontario, K1A 0R6; Telephone (613) 993-6189, Fax (613) 952-0268.





ESR-1269

Issued April 1, 2005

This report is subject to re-examination in one year.

ICC Evaluation Service, Inc.
www.icc-es.org

Business/Regional Office ■ 5360 Wolkman Mill Road, Whittier, California 90601 ■ (562) 699-0543
Regional Office ■ 900 Montclair Road, Suite A, Birmingham, Alabama 35213 ■ (205) 599-9800
Regional Office ■ 4051 West Flossmoor Road, Country Club Hills, Illinois 60478 ■ (708) 799-2305

DIVISION: 03–CONCRETE
Section: 03130–Permanent Forms

REPORT HOLDER:

AMVIC INCORPORATED
501 McNICOLL AVENUE
TORONTO, ONTARIO M2H 2E2
CANADA
(416) 410-5674
www.amvicsystem.com
vamend@amvicsystem.com

EVALUATION SUBJECT:

**AMVIC EXPANDED POLYSTYRENE INSULATED
CONCRETE FORMWORK**

1.0 EVALUATION SCOPE**Compliance with the following codes:**

- 2003 *International Building Code*® (IBC)
- 2003 *International Residential Code*® (IRC)
- BOCA® *National Building Code*/1999 (NBBC)
- 1999 *Standard Building Code*® (SBC)
- 1997 *Uniform Building Code*™ (UBC)

Properties evaluated:

- Structural
- Surface-burning characteristics
- Crawl space fire evaluation
- Noncombustible construction

2.0 USES

Amvic Insulated Concrete Formwork is used as a permanent insulating concrete form (ICF) for structural concrete, load-bearing and nonload-bearing, below-grade and above-grade walls. The forms are used in construction of plain and reinforced concrete beams, lintels, exterior and interior walls, and foundation and retaining walls. The forms remain in place after placement and curing of concrete and shall be protected by an approved interior and exterior finish material. The forms are recognized for use in buildings of noncombustible construction when installed in accordance with Section 4.2.7 of this report.

3.0 DESCRIPTION**3.1 General:**

The Amvic Insulated Concrete Formwork is classified as a Flat ICF system, allowing for a solid concrete wall of uniform

thickness (solid rectangular cross section). See Figure 1 of this report for an illustration of the form.

Amvic Insulated Concrete Formwork consists of two expanded polystyrene (EPS) foam plastic boards separated by injection-molded polypropylene webs, which are pre-inserted in the EPS mold before molding so that the webs are partially embedded into the EPS boards. The ICF system also incorporates polypropylene corner rods to assist in the attachment of finish materials. The polypropylene webs, which are spaced 6 inches (152 mm) on center horizontally, maintain the EPS board facings at a fixed clear distance of 4 inches (102 mm), 6 inches (152 mm) or 8 inches (203 mm). EPS boards are 16 inches (406 mm) high by 48 inches (1220 mm) long by 2.5 inches (64 mm) thick, measured at the center of the board. When stacked in a running bond pattern, the Amvic Insulated Concrete Formwork creates a cavity where steel reinforcement bars and concrete are placed. See Figure 1 of this report for typical dimensions.

3.2 Materials:

3.2.1 Foam Plastic: The EPS foam plastic used in the manufacture of Amvic ICF has a flame-spread index of 25 or less and a smoke-developed index of 450 or less when tested in accordance with ASTM E 84 at a maximum thickness of 5 inches. The foam plastic complies with ASTM C 578, Type II.

3.2.2 Polypropylene Webs and Corner Rods: The polypropylene webs are used to connect the EPS boards and for attaching interior and exterior finishes. The webs have openings to permit concrete to pass through. The webs vary in length and have 1½-inch-wide-by-11½-inch-high-by-0.118-inch-thick (38 mm by 292 mm by 3.0 mm) flanges. The plastic flange is embedded ½ inch (12.7 mm) below the outside surface of the EPS form.

The corner rods are 1-inch-by-1-inch (25.4 mm by 25.4 mm) extruded polypropylene hollow square tubes with a wall thickness of 0.125 inch (3.2 mm). The rods shall be field-installed in vertical openings at the corners of the Amvic units to provide a means for attaching interior and exterior wall coverings.

3.2.3 Concrete: Concrete shall be normal-weight concrete complying with the applicable code, having a maximum ¾-inch (19.1 mm) aggregate and a minimum compressive strength of 2,500 psi (17 250 kPa) at 28 days. If construction of the ICF wall system is based on the IRC, the concrete shall comply with Sections R404.4 and R611.6.1 of the IRC.

3.2.4 Reinforcement: Deformed steel reinforcement bars shall have a minimum yield stress of either 40 ksi (275 mPa) or 60 ksi (413 mPa), depending on the structural design, and shall comply with the applicable code. If construction of the ICF wall system is based on the IRC, reinforcement shall comply with Sections R404.4.6 and R611.6.2 of the IRC.

3.2.5 Other Components: When required by the code official, wood members in contact with concrete for plates or

ES REPORTS™ are not to be construed as representing aesthetics or any other attributes not specifically addressed, nor are they to be construed as an endorsement of the subject of the report or a recommendation for its use. There is no warranty by ICC Evaluation Service, Inc., express or implied, as to any finding or other matter in this report, or as to any product covered by the report.



window and door framing shall be preservative-treated in accordance with the applicable code, and shall be attached with hot-dipped galvanized steel fasteners in accordance with Section 2304.9.5 of the IBC. Materials other than wood, such as vinyl, are permitted for window and door framing if approved by the code official.

3.2.6 Standard and Accessory Forms:

- 9-inch (229 mm) Standard Straight Forms
- 9-inch (229 mm) 90-Degree Corner Forms
- 9-inch (229 mm) 45-Degree Corner Forms
- 11 -inch (279 mm) Standard Straight Forms
- 11 -inch (279 mm) 90-Degree Corner Forms
- 11 -inch (279 mm) 45-Degree Corner Forms
- 13-inch (330 mm) Standard Straight Forms
- 13-inch (330 mm) 90-Degree Corner Forms
- 13-inch (330 mm) 45-Degree Corner Forms

4.0 DESIGN AND INSTALLATION

4.1 Design:

4.1.1 General: Structural analysis and design of the concrete shall be prepared in accordance with the manufacturer's recommended design procedure, ACI318 and Chapter 19 of the applicable code. Design loads shall comply with Chapter 16 of the applicable code.

4.1.2 Amvic Insulated Concrete Formwork: Amvic ICF is defined as a Flat ICF wall system and shall be designed and reinforced in accordance with the load tables for Flat ICF forms in Sections R404.4 and R611 of the IRC, provided the building conforms to the applicability limits defined in Sections R404.4.1 and R611.2 of the IRC, or Sections 1916 and 1804.6.2 of the SBC, provided the building conforms to the applicability limits defined in Sections 1916.2 and 1804.6.2.1 of the SBC. When using the code-prescriptive design methods, the wall thickness shall be limited as noted in the applicable code sections referenced above.

Design of foundation wall reinforcement may also be in accordance with the following code sections:

- IRC Section R404.1.2, and Tables R404.1.1(2), R404.1.1(3) and R404.1.1(4)
- BNBC Section 1812.3.2 and Table 1812.3.2(2)
- SBC Section 1804.6

When the forms are installed on buildings that do not conform to the applicability limits of Sections R404.4.1 and R611.2 of the IRC or Sections 1916.2 and 1804.6.2.1 of the SBC, the structural analysis and design of the concrete shall be prepared in accordance with ACI318 and Chapter 19 of the IBC, BNBC, SBC or UBC, or Sections R404.4 and R612 of the IRC, as applicable.

4.1.3 Alternative Design: In lieu of calculations required by Section 4.1.1 of this report, the structural design of reinforced concrete formed by the Amvic ICF is permitted to comply with the *Prescriptive Method for Insulating Concrete Forms in Residential Construction* (publication EB118), dated May 1998, published by the Portland Cement Association (PCA), subject to all applicability and use limits for Flat ICF walls defined in Table 1.1 of that document. The PCA document shall be made available to the code official upon request. Buildings constructed with the Amvic Insulated Concrete Formwork wall system and designed in accordance with this section (Section 4.1.3) shall not exceed a height of two stories plus a basement, where the maximum unsupported wall height is 10 feet (3048 mm).

4.1.4 Design in Accordance with the IRC: Insulating concrete walls constructed with the Amvic ICF wall system shall be designed and constructed in accordance with Sections R404.4 and R611 of the IRC.

4.2 Installation:

4.2.1 General: Amvic ICF shall be installed in accordance with the manufacturer's published installation instructions and this report. The manufacturer's published installation instructions and this report shall be strictly adhered to, and a copy of the instructions shall be available at the jobsite at all times during installation.

The maximum concrete lift height shall be 4 feet (1.2 m). The minimum ambient temperature during placement shall be in accordance with ACI 306.

4.2.2 Interior Finish: The Amvic ICF shall be finished on the interior of the building with an approved 15-minute thermal barrier, such as minimum 1/2-inch-thick (12.7 mm) regular gypsum wall board complying with ASTM C36. The gypsum wall board shall be installed vertically and attached to the flanges of the plastic webs with No. 6, 1⁵/₈-inch-long (41 mm), Type W, coarse-thread, gypsum wallboard screws spaced as required by the applicable code. The maximum allowable capacity of the wall board screws shall be as indicated Table 1 of this report.

4.2.3 Exterior Finish:

4.2.3.1 Above Grade: The Amvic ICF wall system shall be covered on the exterior with an approved wall covering in accordance with the applicable code or a current evaluation report. When regulated by the IRC, the Amvic ICF wall system shall be covered on the exterior with a water-resistive barrier, in accordance with Sections R703.1 and R703.2 of the IRC, and with an approved wall covering in accordance with the IRC or a current evaluation report. The wall covering shall be attached to the flanges of the plastic webs and the Amvic corner rods using either minimum No. 6, Type S, fine-threaded drywall screws, or minimum No. 6, Type W, coarse-thread drywall screws. The maximum allowable capacity of the wall board screws shall be as indicated in Table 1 of this report. The fasteners shall be corrosion-resistant and have a sufficient length to penetrate the flanges of the webs and the wall of the corner rods by a minimum of 1/4 inch (6.4 mm). A continuous length of the Amvic corner rods shall be field-installed in walls with a maximum total height of 25 feet (7620 mm) in the preformed slot of the 90-degree corner units.

4.2.3.2 Below Grade: For basement wall installations, the ICF surfaces shall be dampproofed or waterproofed in accordance with the applicable code. The dampproofing and waterproofing materials shall be approved by Amvic Incorporated and the code official, and shall be free of solvents, hydrocarbons, ketones or esters that will adversely affect the EPS foam boards. No backfill shall be permitted to be applied against the wall until the complete flooring system is in place, unless the wall is designed as a freestanding wall that does not rely on the flooring system for structural support.

4.2.4 Crawl Space Installation: The Amvic ICF may be installed in a crawl space without a covering applied to the crawl space side of the foam plastic, provided all the following conditions are met:

1. Entry to the crawl space is limited to service of utilities, and heat-producing appliances are not permitted,
2. There are no interconnected basement areas,
3. Air in the crawl space is not circulated to other parts of the building.
4. Ventilation of the crawl space is provided in accordance with the applicable code.



4.2.5 Foundation Walls: The ICF wall system is permitted to be used as a foundation stem wall when supporting wood-framed construction provided the forms are supported by approved concrete footings complying with the applicable code. Compliance with UBC Table 18-1-C is mandatory in jurisdictions adopting the UBC. When regulation is by the IRC, installation of the Amvic ICF system as foundation walls shall comply with IRC Sections R320.4 and R404.

4.2.6 Protection Against Termites: In jurisdictions that have adopted the IRC or SBC, where the probability of termite infestation is defined as "very heavy" by the code official, the foam plastic shall be installed in accordance with Section R320.4 of the IRC and Sections 1916.7.5 and 2603.3 of the SBC, as applicable. Areas of very heavy termite infestation shall be determined in accordance with Figure R301.2 (6) of the IRC and Figure 2304.1.4 of the SBC, as applicable.

4.2.7 Installation in Buildings Required to be of Noncombustible Construction: For the purposes of this report, noncombustible construction is defined as Type I, II, III or IV under the IBC; Type 1, 2, 3 or 4 under the BNBC; Type I, II, III, IV or V under the SBC; or Type I or II under the UBC. The Amvic forms are recognized for use in buildings of noncombustible construction provided the Amvic forms are used to form solid concrete walls and comply with the following:

4.2.7.1 Exterior Walls of Buildings of any Height: The walls shall have an exterior wall covering complying with Section 4.2.7.1.1 of this report, and an interior wall covering complying with Section 4.2.7.1.2 of this report, and shall have fire blocking complying with Section 4.2.7.1.3 of this report:

4.2.7.1.1 EIFS and One-coat Stucco – Exterior Finish: The following EIFS and one-coat stucco lamina shall be installed over the exterior of the forms using the reinforced fabric or lath, base coat and finish coat materials described in their respective evaluation reports, as follows:

- Dryvit Systems, Inc., Outsulation EIFS as described in ESR-1232.
- Senergy, Inc., Senerflex EIFS as described in ER-3850.
- Finestone EIFS as described in ER-4455.
- Sonowall Stucco Systems Sonoborn Flex Wall Stucco Systems as described in ER-5678.

4.2.7.1.2 Interior Finish: The forms shall be finished on the interior with an approved 15-minute thermal barrier, such as 1/2-inch-thick (12.7 mm) gypsum board, as required by the applicable code. The gypsum board shall be installed vertically and attached to the flanges of the plastic webs with No. 6, 1 5/8-inch-long (41 mm), Type W, coarse-thread gypsum wallboard screws spaced 12 inches (305 mm) on center in the field of the board and 8 inches (203 mm) on center on the perimeter.

4.2.7.1.3 Fireblocking: Foam plastic on the interior shall be discontinuous at floor lines. Floor-to-wall intersections shall be constructed to prevent the passage of flame, smoke and hot gasses from one floor to another.

4.2.7.2 One-story Buildings: The following conditions apply:

4.2.7.2.1 Fire Sprinklers: The building shall be equipped throughout with an automatic sprinkler system in accordance with the applicable code.

4.2.7.2.2 Exterior Finish: The exterior of the foam wall shall be covered with metal of a thickness of not less than 0.032 inch (0.81 mm), or aluminum or corrosion-resistant steel having a base-metal thickness of 0.016 inch (0.41 mm).

4.2.7.2.3 Interior Finish: The forms shall be finished on the interior with an approved 15-minute thermal barrier such as

1/2-inch-thick (12.7 mm) gypsum board, as required by the applicable code. The gypsum board shall be installed as described in Section 4.2.2 of this report.

4.2.7.2.4 Fireblocking: Foam plastic on the interior shall be discontinuous at floor lines. Floor-to-wall intersections shall be constructed to prevent the passage of flame, smoke and hot gasses from one floor to another.

4.2.8 Special Inspection:

4.2.8.1 IBC: Special inspection shall be required as noted in IBC Section 1704 for placement of reinforcing steel and concrete, and for concrete cylinder testing.

4.2.8.2 IRC: For walls designed in accordance with Section 4.1.2 of this report, special inspection is not required. For walls designed in accordance with the IBC, as permitted by IRC Sections R104.11 and R301.1.2, special inspection in accordance with Section 4.2.8.1 of this report is required.

4.2.8.3 UBC: Special inspections are required in accordance with UBC Section 1701 for placement of reinforcing steel and concrete, and for concrete cylinder testing. When approved by the code official, special inspection may be waived when all the following conditions are met:

1. Walls are a maximum of 8 feet (2.4 m) high, and are limited to use in single-story construction of Group R, Division 3, or Group U, Division 1, Occupancies.
2. Maximum height of a concrete pour is 48 inches (1219 mm). Succeeding lifts shall be placed in accordance with UBC Section 1905.1 0.5.
3. Installation shall be by installers approved by Amvic.
4. Half the allowable stresses or loads permitted by the UBC are used for design of the walls.

5. Installation instructions indicate methods used to verify proper placement of concrete.

4.2.8.4 BNBC: Special inspections are required as noted in BNBC Section 1705.4, and shall include, but not be limited to: verification of material specifications for concrete, reinforcing steel and formwork materials; installation of reinforcing steel; formwork installation; bracing; and concreting operations.

4.2.8.5 SBC: Special inspections are required as noted in SBC Section 1707.1, and shall include, but not be limited to: verification of material specifications for concrete, reinforcing steel and formwork materials; installation of reinforcing steel; formwork installation; bracing; and concreting operations.

5.0 CONDITIONS OF USE

The Amvic Insulated Concrete Formwork described in this report complies with, or is a suitable alternative to what is specified in, those codes listed in Section 1.0 of this report, subject to the following conditions:

5.1 The ICF units shall be manufactured, identified and installed in accordance with this report and the manufacturer's published installation instructions. If there is a conflict between the manufacturer's published installation instructions and this report, this report shall govern.

5.2 When required by the code official, calculations showing compliance with the general design requirements of Chapter 16 of the applicable code shall be submitted to the code official for approval, except calculations are not required when the building design is based on Section 4.1.3 or 4.1.4 of this evaluation report.

5.3 The forms shall be separated from the building interior with an approved 15-minute thermal barrier, except for crawl space construction as described in Section 4.2.4 of this report.



- 5.4 Amvic Insulated Concrete Formwork shall be limited to buildings of combustible [Type V (IBC and UBC), Type 5 (BNBC) and Type VI (SBC)] construction, except as described in Section 4.2.7 of this report.
- 5.5 When used in buildings required to be of noncombustible construction, one label as described in Section 7.0 of this report shall be visible in every 160 square feet (14.9 m²) of wall area.
- 5.6 Special inspections shall be required as described in Section 4.2.8 of this report.
- 5.7 The forms are produced by Amvic Incorporated in Toronto, Ontario, Canada, under a quality control program with inspections by Intertek Testing Services NA, Ltd.-Warnock Hersey (AA-688).
- 6.0 EVIDENCE SUBMITTED**
- 6.1 Manufacturer's published installation instructions.
- 6.2 Data in accordance with the ICC-ES Acceptance Criteria for Concrete Floor, Roof and Wall Systems and

Concrete Masonry Wall Systems (AC15), dated June 2003 (editorially revised March 2005).

- 6.3 Data in accordance with the ICC-ES Acceptance Criteria for Foam Plastic Insulation (AC12), dated October 2004, including reports of comparative crawl space fire tests and a report of room corner fire test in accordance with UL 1715 and UBC Standard 26-3.
- 6.4 Reports of fastener withdrawal and lateral load tests.
- 6.5 A quality control manual.

7.0 IDENTIFICATION

Each pallet of forms shall be labeled with the Amvic name and/or trademark, the product name, the inspection agency name and/or trademark (Intertek Testing NA Ltd. – Warnock Hersey) and the evaluation report number (ESR-1269). Additionally, one form on each pallet shall be labeled on both sides of the form with the same information.

TABLE 1 – ALLOWABLE PULLOUT AND LATERAL LOAD CAPACITIES OF SCREWS

SCREW TYPE	ALLOWABLE CAPACITY (POUNDS)	
	Withdrawal	Lateral Load
No. 6, Type S, fine-thread, corrosion-resistant drywall screw	27	39
No 6, Type W, coarse-thread, corrosion-resistant drywall screw	29	42

For **SI**: 1 pound = 4.45 N.



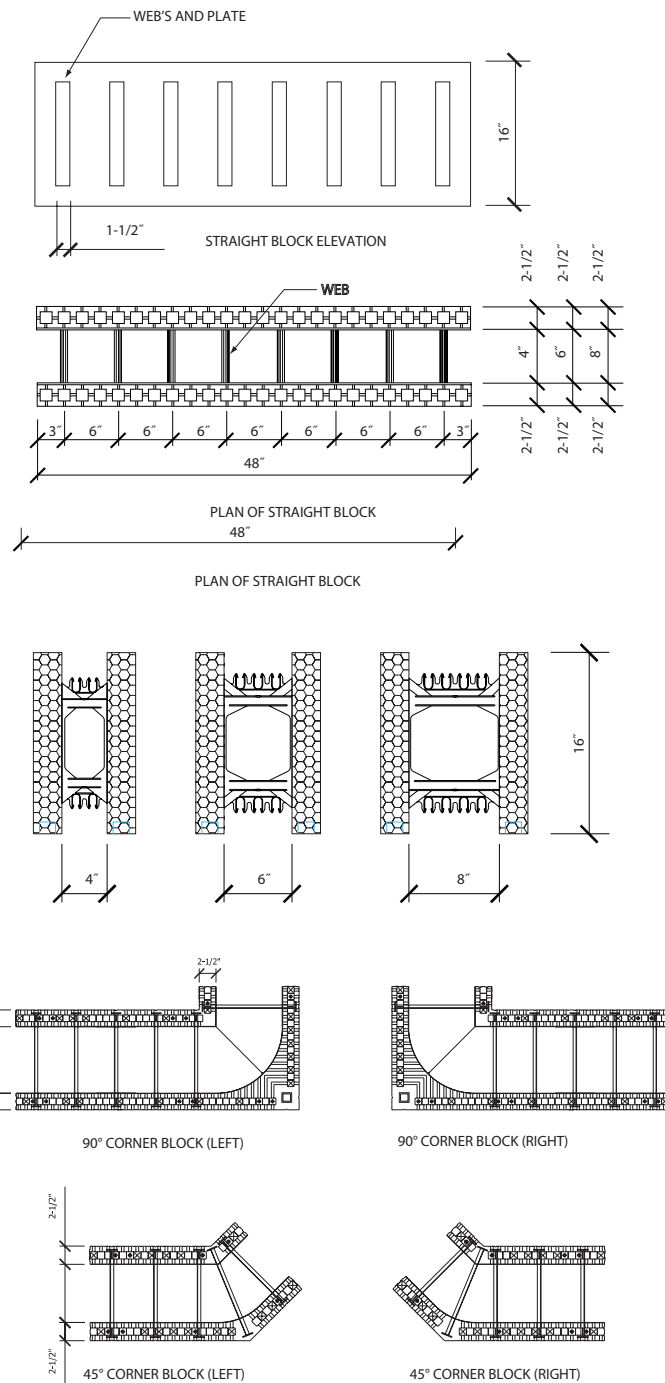

FIGURE 1 – FORM SHAPES





Part 8 – Special Topics

8.1 Utility Service Installations

8.1.1 – ICF Wall Penetrations

The electrician, plumber, HVAC installer etc. should block out service penetrations through the walls. After the ICF has been stacked and before the concrete is poured. Blocking out for service penetrations is typically done by cutting a hole through the ICF and inserting PVC pipe all the way through both sides. The PVC pipe serves as a sleeve for subsequent installation of wiring, hose bibs, cables and other service utilities required for the structure. Foam adhesive can be used to seal the gaps between the PVC pipe and the Amvic ICF EPS panels.



Important Note!

All penetration sleeves should be installed at an angle pointing downward towards the exterior of the building. This is to ensure that if any water accumulates or is trapped in, it will be drained to the outside.

Sleeves should be sealed with a weather tight caulk or foam after all wiring has been installed.



8.1.2 – Electrical Installation

8.1.2.1 – Main Entrance Panel

The main electrical panel for a building is typically located internally in an independent room or enclosure. If the main electrical panel is to be installed flush with an exterior wall, build the equivalent of a door buck with the appropriate dimensions. The buck height should be enough to leave a gap of approximately 12-18 inches (30 – 45 cm) above the panel to allow easy access for the electrician to pull wire out of the top and swing it over to be embedded in the ICF EPS above. Wiring can then be carried to the upper floors and attic.

If power is entering from underneath the electrical panel, install sweeps through the foundation/SOG allowing it to enter within the opening formed by the buck.



Figure 8.1 – Main electrical panel installed flush with exterior wall



8.1.2.2 – Electrical Wiring

Wiring is installed in Amvic ICF walls after the concrete is poured by cutting channels in the EPS panels in which the Romex wires are embedded. The most efficient way of cutting the channels is by using a chainsaw with a depth stop installed.



Figure 8.2 – Cutting a channel in the EPS panel using a chainsaw

The Romex wires will most likely stay embedded in the EPS panels by friction, however, in addition, use foam adhesive to glue the wires to the EPS occasionally in the same manner staples are used with wiring for conventional framing.

Use protective nail plates over the wiring in places where it could be hit by drywall screws.





Figure 8.3 – Embedding Romex into the EPS panels

8.1.3 – Conduit

Conduit is installed in the same manner as wiring, by cutting a channel in the EPS after the walls are poured in which the conduit is embedded.

If the conduit is to be embedded in the concrete cavity, then it is installed prior to the concrete pour. Electrical boxes and sweeps to which the conduit will be attached should also be installed before the pour.

8.1.4 – Electric Outlet Boxes

Electric outlet boxes are installed in Amvic ICF after the concrete is poured by cutting out a recess in the EPS panel using a hot knife adjusted for the right depth. The EPS panels on the Amvic ICF are 2.5 inches (63.5 mm) thick, which is enough depth for most electrical boxes.

If electrical boxes are deeper than 2.5 inches (63.5 mm) then installation should be carried out before the concrete is poured.



8.1.4.1 – Attaching the Electrical Box to the Wall

Electrical boxes are secured to the ICF wall by:

1. Friction with the EPS foam,
2. Foam adhesive,
3. Screws.



Figure 8.4 – Electric box with flange attached to the webs



8.1.5 – Plumbing

Plumbing is installed in the same manner as conduit and wiring, by cutting channels in the EPS foam after the concrete pour and embedding the pipes. Foam adhesive is used to secure the pipes in place.



Figure 8.5 – Vent pipe embedded in the EPS foam

If brackets for fixtures are required, concrete screws can be used to secure the brackets to the concrete.

Larger diameter plumbing pipes e.g. 3 inch (76 mm) or larger vents can be installed by furring out the ICF wall to accommodate them or by creating chases made of wood or metal in which the pipes are hidden and can be easily accessed for maintenance.

It is not recommended to place plumbing pipes in the concrete cavity of ICF walls because it creates a weak spot. If it is essential to run the pipes in the concrete cavity for architectural aesthetics, a local licensed/registered engineer should design and/or approve such a detail.



8.2 Below Grade Moisture Protection

8.2.1 – Code Requirements

All building codes in the US and Canada require walls below grade to have damp-proofing or waterproofing protection.

8.2.1.1 – *Damp-proofing vs Waterproofing*

Damp-proof applications will slow or retard water and water vapor penetration through the foundation walls. When applied properly, damp-proofing can keep basements in a dry condition as long as there is no hydrostatic pressure due to ground water table.

Waterproof applications stop water from infiltrating foundation walls. Waterproof applications in most cases are more expensive than damp-proofing. The investment is well worth it considering the repair costs involved, if a basement wall starts to leak water.

8.2.1.2 – *Damp-proofing or Waterproofing According to Building Codes*

Damp-proofing is required for foundation walls enclosed within soils where hydrostatic pressure does NOT occur.

If it is determined by a soil investigation report that hydrostatic pressure conditions exist, then the enclosed foundation walls shall be waterproofed. When walls are waterproofed, no damp-proofing is required.

8.2.1.3 – *Foundation / Subsoil drainage system as per Building Codes*

Proper drainage of the subsoil is required for all walls which retain soil and enclose habitable space. The drain shall be placed around the perimeter of the foundation wall at or below the footing or SOG level. The drains can be made of drainage tiles, gravel or crushed stone drains, perforated pipe or other approved systems. The drains shall discharge water by gravity or mechanical means into an approved drainage system.



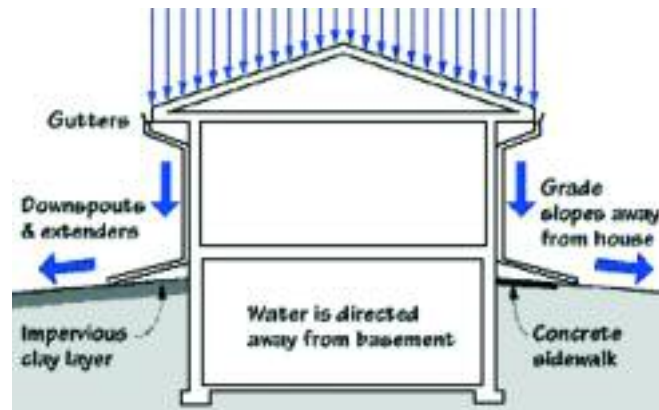

Figure 8.6 – Recommendations for dry basement

8.2.2 – Damp-proofing & Waterproofing Applications for Amvic ICF

There are 3 types of membranes that can be applied to Amvic ICF including liquid applied membranes, peel & stick membranes and dimple sheets.

Each of the three types has advantages and disadvantages. Before deciding on which one to use, consider the following:

1. **Local availability** – Check with the local Amvic distributor for appropriate product availability.
2. **Product Technical Information** – Ensure that product of choice has the proper technical information with regards to specifications, installation instructions and meets the local building code requirements.
3. **Manufacturer warranty** – The product manufacturer should have a product warranty against production deficiencies. Some manufacturers offer up to 30 years of warranty on their products.
4. **Installer Warranty** – The contractor installing the product should offer an installation warranty to guarantee installation and performance for a certain period of time.
5. **Installer Experience** – It is recommended to ask your installer about his experience using the products available.
6. **Price** – Higher performance products will almost always cost more. Carefully weigh the benefits against the costs before making a decision on which product to use.



8.2.3 – Liquid Applied Damp-proofing / Waterproofing Systems

Liquid applied membranes usually come in pails of 5 US gallons (18.925 litres) each. Depending on which product is being used, the membrane can be applied using a trowel, brush, roller or spray.

To protect the liquid applied membrane from sharp/heavy gravel in the backfill soil, Amvic recommends installing protective boards or drainage composites. The protective boards/drainage composites will be applied over the liquid applied membrane and have the added benefits of additional moisture protection and provide air channels for water to be carried by gravity to the footing drain.



Figure 8.7 – Spraying liquid applied membrane on Amvic ICF



Recommended liquid applied membrane products for Amvic ICF include:

1. Blue Seal Waterproof Rubber Membrane – www.bluesealwaterproofing.com
2. BAKOR, Aqua-Bloc® 720-38 – www.bakor.com
3. Carlisle, BARRICOAT-R – www.carlisle-ccw.com
4. Epro, Ecoline-R and Ecoline-S – www.eproserv.com



Warning!

Liquid applied damp-proofing / waterproofing membranes MUST be water based and free of any solvents. Follow the manufacturer installation requirements.

8.2.4 – Peel & Stick Damp-proofing / Waterproofing Systems

Peel and Stick systems are made of membranes which adhere directly to the EPS on Amvic ICF. One side of the membrane has a thin film of glue which is protected by a paper sheet. Once the paper sheet is peeled off, the membrane is adhered in place as per the specific installation guide of the manufacturer.



Warning!

Any primer used prior to the peel and stick application MUST be water based and free of any solvents.

In most cases the manufacturer will also recommend a specially formulated primer to be applied to the face of the EPS before applying the membranes which will help improve their adhesion. Peel and stick membranes may require a protection layer against sharp/heavy gravel. Check manufacturer specifications.



Figure 8.8 – Peel and stick waterproofing membrane installed and ready to be backfilled



Recommended peel and stick membrane products for Amvic ICF include:

1. SOPREMA, COLPHENE ICF – www.soprema.ca
2. BAKOR, Blueskin® WP 200 – www.bakor.com
3. CARLISLE, MiraDri 860/861 – www.carlisle-ccw.com
4. Polyguard, POLYGUARD 650 MEMBRANE – www.polyguardproducts.com
5. Polyguard, POLYGUARD 650 XT MEMBRANE, for waterproofing AND termite protection – www.polyguardproducts.com

8.2.5 – Dimple sheet Damp-proofing / Waterproofing Systems

Dimple sheet membranes are wrapped around the foundation walls with the dimple side facing the EPS on the Amvic ICF creating an air gap between the back fill soil and the walls. This air gap prevents the build up of direct hydrostatic pressure over the walls and thus moisture in the soil cannot penetrate through to the inside of the basement. When installed properly, dimple sheet membranes have been used with success throughout North America.



Figure 8.9 – Installed dimple sheet membrane



Recommended dimple sheet damp-proofing / waterproofing products for Amvic ICF include:

1. Armtec Limited, System Platon – www.systemplaton.com
2. DMX PLASTICS – DMX Flexsheet™ – www.dmxplastics.com

8.2.6 – Parging

Most building codes in North America will require the exterior finish siding to start at a distance not less than 6 to 8 inches (150 to 200 mm) above grade level. The exposed EPS area between the grade and the exterior siding finish must be covered. A parge coat (cementitious coat) is most often used to cover the EPS to protect it from weathering effects.

Before applying the parge coat, the EPS must be clean of any dirt or debris and dry to ensure proper adhesion. Amvic recommends using **Durock Prep-Coat B-2000** with reinforcing fiber mesh or equivalent. The parging coat should overlap the damp-proofing/waterproofing membrane by 2 inches (50 mm).



8.3 – Termites and ICF construction

The EPS foam and concrete which make up the Amvic ICF do not constitute a food source for any of the three types of termites found in North America. However subterranean termites can burrow through the EPS foam to reach areas of the building structure where there is a food source such as roof wood trusses, wood floor joists and hardwood flooring.

When ICF walls are used below grade in areas of very heavy termite infestations, it becomes more difficult to track their existence since termites can start burrowing through the EPS foam starting from below grade and upwards to the roof without being discovered.

8.3.1 – Code Issues and EPS Foam Below Grade

The subterranean termites' ability to burrow through below grade EPS foam undiscovered, led several national and local building codes in North America to ban the use of EPS foam below grade in areas considered to be very heavily infested. However the building codes have made exceptions and suggested measures which, if used, will make the use of EPS foam acceptable.

8.3.1.1 – *International Residential Code 2003, Termite Control and EPS Protection*

[R320.1] Subterranean termite control.

In areas favorable to termite damage as per table R301.2(1) methods of protection shall be any of the following:

1. Chemical soil treatment
2. Pressure preservatively treated wood in accordance with AWPA standards
3. Naturally termite resistant wood
4. Physical barriers such as metal or plastic termite shields
5. Any combination of the above



[R320.4] Foam Plastic Protection.

In areas where the probability of termite infestation is ‘very heavy’ as per figure R301.2(6) [refer to figure D1.3 below], EPS foam shall not be installed on the exterior face or under interior or exterior foundation walls or slab foundations located below grade. There should be a minimum clearance of at least 6 inches (152 mm) between foam plastics installed above grade and exposed earth.

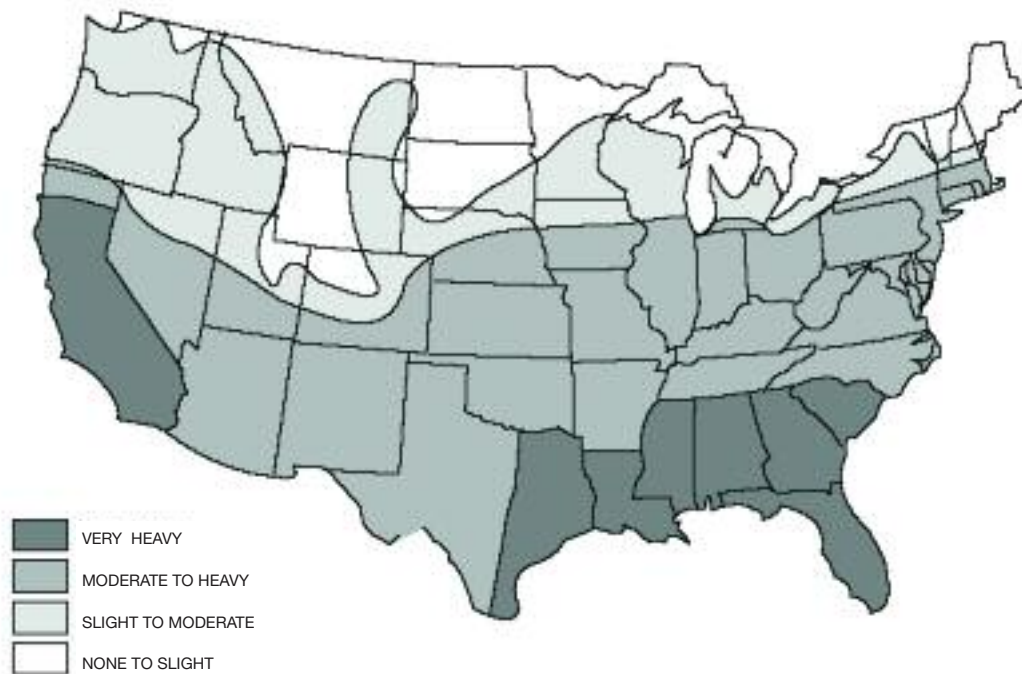

Note: Lines defining areas are approximate only. Local conditions may be more or less severe than indicated by the region classification.

Figure 8.10 – Illustration R301.2(6) as per IRC 2003

Exceptions:

1. Building structural members of walls, floors, ceilings and roofs are entirely of noncombustible materials or pressure preservatively treated wood.
2. In addition to requirements of R320.1, an approved method of protecting the foam plastic and structure from subterranean termite damage is provided.
3. On the interior side of basement walls.



8.3.1.2 – National Building Code of Canada 2005, Termite Control and EPS Protection

[NBC 2005 – 9.12.1.1 (2)]

In localities where termite infestation is known to be a problem, all stumps, roots and other wood debris shall be removed from the soil to a depth of not less than 300 mm in unexcavated areas under a building.

[NBC 2005 – 9.3.2.9 (1)]

In localities where termites are known to occur,

- a) clearance between structural wood elements and finished ground level directly below them shall be not less than 450 mm and, except as provided in sentence (2), all sides of the supporting elements shall be visible to permit inspection, or
- b) structural wood elements, supported by elements in contact with the ground or exposed over bare soil, shall be pressure treated with a chemical that is toxic to termites.

[NBC 2005 – 9.3.2.9 (2)]

In localities where termites are known to occur and foundations are insulated or finished in a manner that could conceal termite infestation,

- a) a metal or plastic barrier shall be installed through the insulation and any other separation of finish materials above finished ground level to control the passage of termites behind or through the insulation, separation or finish materials, and
- b) all sides of the finished supporting assembly shall be visible to permit inspection.

8.3.2 – Termite Protection and Control

There are several methods for protecting below grade and above grade structures including EPS foam from termites. The following are the most common methods currently being used in the market and are categorized according to their specific application techniques.



8.3.3 – Physical Barriers

8.3.3.1 – *Waterproofing and Termite Barrier System.*

Polyguard 650 XT membrane is specifically designed for ICF foundation walls and can be used for foundation waterproofing as well as termite protection.

Compliance of Polyguard 650 XT membranes with building codes issues pertaining to waterproofing and termite protection is covered under the International Code Council *ICC-ES Legacy Report #2136 (Formerly SBCCI Evaluation Report #2136)* which can be downloaded from the following website:

www.polyguardproducts.com/products/architectural/datasheets/ICC-ESreport2136.pdf

For more information on Polyguard 650 XT refer to the following website:

www.polyguardproducts.com/products/architectural/icf.htm

8.3.3.2 – *Chemical Treatment of Soil*

Adding chemicals (termiticide) to the soil surrounding the building structure has been a traditional and primary method of termite control. Subsequent follow up treatment at regular periodic intervals is required to continuously keep any termite population near the structure in check.

Certain city by-laws have been known to ban this method in areas where the water-table level is very high and there is an environmental danger of the chemical agents seeping through.

8.3.3.3 – *Metal Termite Shield*

Metal termite shields are physical barriers to termites which prevent them from building invisible tunnels. When installed properly, the metal termite shields will force subterranean termites to build tunnels on the outside of the shields which are easily detected.

Metal shields are installed on top of concrete walls, and are fabricated of sheet metal which is unrolled and attached over the foundation walls. The edges are then bent at a 45 degree angle. Metal shields must be very tightly constructed, and all joints must be completely sealed. Joints may be sealed by soldering, or with a tar-like bituminous compound.





Figure 8.11 – Metal termite shield using copper metal on top of foundation wall.
Copyright ©1998-2005, Urban Entomology Program, University of Toronto
www.utoronto.ca/forest/termite/termite.htm



Figure 8.12 – Detail of metal shield at corner.
Copyright ©1998-2005, Urban Entomology Program, University of Toronto
www.utoronto.ca/forest/termite/termite.htm



8.3.3.4 – Particle Sized Barrier

A physical barrier consisting of particle-sized rocks, such as crushed basalt, silica sand, natural sand, granite, glass shards, limestone, quartz and coral sand, can be used to prevent termite entry. There are three basic requirements that must exist for a particle sized barrier to be effective:

1. Granules size must be small enough so that when compacted together, the space between them is too small for the termites to squeeze through.
2. Granules must be big and heavy enough so that the termites can't pick them up and move them using their mandibles.
3. Granules must be too hard for the termites to chew.

The current studies conducted by entomologists reveal that particle sizes between 1.4 - 2.8 mm are impenetrable to subterranean termites.

Particle-sized barriers are used under slabs, around foundations, and around plumbing to create a physical barrier against termites.

An example of a successful particle sized barrier is the Basaltic Termite Barrier (BTB) made of crushed and/or sieved basalt. BTB was invented in Hawaii and is currently being used extensively throughout the state for new commercial and residential construction. BTB is made commercially available by Ameron and under license from the University of Hawaii. For more information on the availability of BTB please refer to the following website:

Ameron, Basaltic Termite Barrier (BTB) – www.ameronhawaii.com/plagg.html

8.3.3.5 – Termimesh

Termimesh is a marine grade 316 stainless steel wire mesh which protects the foundation walls and slab on grade of a structure from termite penetration. The aperture grille of the mesh is too small for the termites to penetrate and too hard for them to chew. Termimesh will not kill or eliminate termites. It will physically prevent termites from penetrating a building structure.

Termimesh can be installed during construction on the exterior of foundation walls, under the slab on grade, and around service pipes penetrating the structure. For the system to be effective, proper installation is critical. Termimesh can only be installed by licensed professionals who have been trained by the company to specifically install Termimesh.



Compliance of Termimesh with building code requirements for termite protection is covered by the *Southern Building Code legacy report No. 9713B* which can be downloaded from the following website:

www.icc-es.org/reports/pdf_files/SBCCI-ES/9713B.pdf

For more information on this product and its availability please refer to following website:

www.termi-mesh.com

8.3.4 – Suppression

8.3.4.1 – Termite Baits

Termite bait systems were developed based on the social behavior of insects to groom and feed each other thereby transferring chemical toxicants to a termite colony and eventually eliminating it.

Wood or some other type of cellulose is used in termite baits, to attract foraging termite workers. The cellulose is impregnated with a slow-acting toxicant that cannot be detected by the termites. The toxicant must be slow acting because termites tend to avoid sites where sick and dead termites accumulate. Termite workers feed on the treated material and carry it back to other colony members, where it slowly poisons the termites and eventually reduces or eliminates the entire colony.

Typically, in-ground stations are inserted in the soil next to the structure and in the vicinity of known or suspected sites of termite activity. Initially the stations contain untreated wood to serve as a monitoring device. Once termites locate and start feeding on it, the wood is replaced with the slow acting chemical toxicant. In addition, aboveground stations may be installed inside or on the structure in the vicinity of damaged wood and shelter tubes.





Figure 8.13 – Inserting a termite trap containing wood as bait

Termite baits are used for controlling termite infestations rather than being a barrier to prevent termites from penetrating a structure.

There are several commercial termite bait systems available on the market including:

1. Dow AgroSciences LLC - **Sentricon® Colony Elimination System**
www.sentricon.com
2. FMC Corporation - **FirstLine® Termite Defense System**
www.fmc-apgspec.com
3. BASF Corporation - **Subterfuge® Termite Bait**
www.spd.basf-corp.com/default.asp?page=pestpro/products/subterfuge
4. Ensystem Inc. - **EXTERRA™ Termite Interception and Baiting System**
www.ensystem.com



8.3.4.2 – *Trap Treat Release (TTR)*

TTR is similar to termite baits in that it uses their social behavior to spread slow acting chemical toxicants into a termite colony.

With TTR, termite traps are placed in suitable locations near the structure. The traps are checked regularly for termite presence. Once termites hit a trap, it is removed and the termites are extracted for treatment. A slow acting chemical toxicant is applied externally to termite bodies as a groomable coating. After treatment the termites are released back to their colonies. Coated termites carry effectively larger loads of toxicant than do bait-fed termites.

These topically treated termites act as a delivery system, spreading the toxicant throughout the colony. Cleaning and grooming by other members of the colony, result in the ingestion of the pesticide by the grooming individuals. After ingestion, the pesticide is further distributed by mutual feeding behaviors. Because of its more efficient delivery system, TTR has better results in the laboratory and field conditions than bait systems.

TTR was developed by Dr. T. G. Myles at the University of Toronto, and was licensed by the University of Toronto Innovations Foundation to FMC Corporation.

8.3.5 – Site Management

The following are measures to be taken during construction to reduce the probability of termite infestation in a building structure. These measures are meant to be used **IN ADDITION** to the other termite prevention and control methods discussed above and should not be used nor considered as standalone solutions.

1. Building sites should be cleared of stumps, roots or other woody material that remains beneath or adjacent to the building.
2. All stakes, forms and building debris should be removed from beneath and adjacent to buildings. Do not backfill over such debris.
3. The site should be well drained so that moisture is not retained under, or adjacent to, a building. Downspouts should carry water away from the building.
4. No wood (stair supports, posts or other wood) should project through concrete floors or foundations.



5. Foundations should be of concrete or masonry, and soil debris should be kept clear of wood resting on them. Make sure foundation wall is high enough to allow sufficient topsoil placement and still leave at least 6-8 inches (15-20 cm) of clearance between the bottom of siding or stucco and the ground.
6. Slabs, concrete floors and foundation joints should be sealed against moisture, and regularly inspected for cracks which should be immediately sealed.
7. In areas determined to be very heavily infested with termites, it is recommended to remove an 8 inch (20 cm) strip of EPS above the grade line to expose the concrete. Any termite shelter tubes will be clearly visible and the required treatment measures can be adopted.

8.3.6 – Recommendations for Termite Prevention and Control

1. Wood or cellulose is the main food source for termites. Reducing or eliminating wood structural elements in a building structure, greatly enhances its durability against termite infestation. If wood cannot be eliminated, use treated wood or naturally resistant wood to termites.
2. Consider using more than one line of defense from the three different categories of termite control and prevention methods discussed above (Physical Barriers, Suppression and Site Management).
3. Always retain the services of licensed/professional Pest Control Operators (PCOs) to implement commercial termite control and prevention methods especially chemical treatment of soils, metal termite shields, termite baits and TTR.
4. Monitor the structure on a regular basis and inspect for any signs of termite infestation or damage. This should be performed by professional PCOs. Take remediation action when termites are discovered.



8.4 Green Construction with Amvic ICF

8.4.1 Green Building

Green building refers to using resources more efficiently, while creating healthier and more energy-efficient structures. Success is measured by the ability to reduce the “footprint” left on the environment through the conservation of resources while balancing energy-efficiency, cost effectiveness and reduced maintenance costs over time.

8.4.2 Green Characteristics of Amvic ICF

Amvic ICFs are perfectly suited for Green Building and have various attributes which contribute to the green elements of a structure which are described below.

Reduced Energy Consumption

Amvic ICF structures generally result in a monthly reduction in energy consumption of up to 30-50% for heating and air conditioning, when compared to frame construction. Over a structure’s lifetime, this greatly contributes to the conservation of fossil fuels. During the construction process, much less energy is also used compared to frame construction since the amount of tools and equipment required for wall assembly is minimal.

Reduced Emissions

The reduction in energy consumption for Amvic ICF structures, translates to an equivalent reduction in harmful emissions which are currently damaging the earth’s atmosphere. Also, no CFCs, HCFCs or other harmful chemicals or gases are used in manufacturing of Amvic ICFs and no off gassing is present.

Recycled Materials

The webs used in Amvic ICF are made from recycled polypropylene resulting in the forms being over 60% recycled content by weight. In most cases, recycled salvaged steel is used to manufacture the reinforcing steel that is used within the walls and recycled ingredients are used in the concrete mix. The concrete mix recommended by Amvic requires that 20-30% of the Portland cement be replaced with fly ash which would otherwise be sent to landfills. According to the EPA, every ton of coal ash used in concrete to replace Portland cement reduces 0.89 tons of greenhouse gas emissions.



Reduced Material Wastage

The unique design of Amvic ICFs can result in less than 1-2% material waste when installed properly, compared to approximately 6% for competing ICFs. Conventional construction typically yields 15% new material wastage in the construction of the shell of a house, which comprises 65% of the waste entering the nation's landfills. The concrete and steel used within the walls also results in minimal waste.

Sustainability

Amvic ICF structures are extremely durable and have an expected lifetime in excess of 100 years with minimal maintenance. When compared to frame structures, this is approximately 4 times longer. Amvic structures are also far more likely to withstand fires, severe weather and natural disasters. This greatly reduces the future environmental impact which would otherwise come from dramatically greater maintenance and repair.

Scarce Resource Protection

Construction of an Amvic ICF structure conserves many trees which would normally be used for conventional wood framing. The use of concrete is far less taxing on the environment as it uses the most abundant resources on the planet in its composition: gravel aggregate and limestone.

High Indoor Air Quality

The use of EPS insulation Amvic ICF eliminates all air borne glass fibers and insulation settlement in the home caused by traditional fiberglass insulation. Also, the impermeable walls prevent the entry of dust, pollens and pollution. Maximum indoor air quality can be provided effectively and at reduced energy cost through the implementation of high efficiency air filters. Amvic ICF homes qualify for Enviro-home status in Canada, which is the highest possible air quality rating given to an occupied shelter.



8.4.3 Contribution to LEED Certification

The USGBC's LEED Certification program provides a framework for assessing building performance and sustainability based on water savings, energy efficiency, materials selection and indoor environmental quality. Amvic ICFs can contribute to the LEED certification of a structure through the accumulation of points based on the categories mentioned above. When used in conjunction with other materials, Amvic ICF can contribute up to **28 points** towards a structure's LEED certification.

8.4.4 LEED Product Assessment Form

The following LEED Product Assessment Report was prepared for Amvic by an unbiased third party. The document outlines the areas where Amvic ICF can contribute to the accumulation of LEED points.





AMVIC ICF
LEED Product Assessment Report
Last Updated: September 25th, 2006



Yes	Y1	Y2	N1	N2	No	13 Sustainable Sites		14 Points	Description	Amvic Direct Benefit?		Comments	Benefits
						Yes	No			Yes	No		
1							Erosion & Sedimentation Control	Required	The design of a sediment and erosion control plan to prevent less of soil, sedimentation into storm sewer or receiving streams, and air pollution.				
							Site Selection	1	To avoid developing a building in inappropriate sites to minimize environmental impacts.		x		
							Urban Redevelopment	1	Channel development to urban areas with existing infrastructure.		x		
							Brownfield Redevelopment	1	Rehabilitate damaged sites where development is complicated by real or perceived contamination.				
							Alternative Transportation, Public Transportation Access	1	Reduce pollution and land development impacts from automobile use.		x		
							Alternative Transportation, Bicycle Storage & Changing Rooms	1	Reduce pollution and land development impacts from automobile use.		x		
							Alternative Transportation, Hybrid & Alternative Fuel Vehicles	1	Reduce pollution and land development impacts from automobile use.		x		
							Alternative Transportation, Parking Capacity and Carpooling	1	Reduce pollution and land development impacts from single occupancy automobile use.		x		
							Reduced Site Disturbance, Protect or Restore Open Space	1	Conserve existing natural areas and restore damaged areas to provide habitat and promote biodiversity.		x		
							Reduced Site Disturbance, Development Footprint	1	Conserve existing natural areas and restore damaged areas to provide habitat and promote biodiversity.		x		
							Stormwater Management, Rate and Quantity	1	Limit disruption and pollution of natural water flows by managing stormwater runoff.		x		
							Stormwater Management, Treatment	1	Limit disruption and pollution of natural water by eliminating stormwater runoff, increasing on-site filtration, and eliminating contaminants.				
							Landscape & Exterior Design to Reduce Heat Islands, Non-Roof	1	Reduce heat-islands to minimize impact on microclimate and human and wildlife habitat.	x			The ICF allows the designer a freedom of choice for exterior finish, including light colored, high albedo materials.
							Landscape & Exterior Design to Reduce Heat Islands, Roof	1	Reduce heat-islands to minimize impact on microclimate and human and wildlife habitat.		x		
							Light Pollution Reduction	1	Reduce light trespass from the building and site, improve night sky access and reduce development impact on nocturnal environments.				

Yes	Y1	Y2	N1	N2	No	5 Water Efficiency		Description	Amvic Direct Benefit?		Comments	Benefits	
						Yes	No		Yes	No			
							Water Efficient Landscaping, Reduce by 50%	1	Limit or eliminate the use of potable water for landscape irrigation				
							Water Efficient Landscaping, No Potable Use or No Irrigation	1	Eliminate the use of potable water for landscape irrigation		x		
							Innovative Wastewater Technologies	1	Reduce generation of wastewater and potable water demand, while increasing the local aquifer recharge.		x		
							Water Use Reduction, 20% Reduction	1	Maximize water efficiency within buildings to reduce the burden on municipal water supply and wastewater systems		x		
							Water Use Reduction, 30% Reduction	1	Maximize water efficiency within buildings to reduce the burden on municipal water supply and wastewater systems		x		

Yes	Y1	Y2	N1	N2	No	17 Points Energy & Atmosphere		Description	Amvic Direct Benefit?		Comments	Benefits	
						Yes	No		Yes	No			
							Fundamental Building Systems Commissioning	Required	Verify and ensure that fundamental building elements and systems are designed, installed and calibrated to operate as intended.				
							Minimum Energy Performance	Required	Establish the minimum level of energy efficiency for the base building systems.	x			AMVIC ICF provides an improved thermal insulation performance level (up to 40%), high thermal mass, plus an improved air-tightness performance. These combined features free the designer to utilize strategies which will improve Building Performance.
							CFC Reduction in HVAC/R Equipment	Required	Reduce the use of CFC-based refrigerants.				
							Optimize Energy Performance	1 to 10	Achieve a minimum energy performance above the prerequisite standards to reduce environmental impacts associated with excessive energy use.	x			An estimated 4 points is associated to the incorporation of AMVIC ICFs based on its contribution to thermal insulation, thermal mass, and improved airtightness performance.
							Renewable Energy, 5%	1	Encourage and recognize the increasing levels of on-site renewable energy in order to reduce the environmental impacts associated with fossil fuel energy use.	x			As the energy performance of a building is improved with an appropriate design using AMVIC ICF, the total energy use of a building will be reduced. As a result, the incremental costs to achieve a desired Renewable energy percentage will be accounted for as an off-set cost in energy savings.

Yes	6	3	2	N7	3	No	Materials & Resources		14 Points	Description	AMVIC Direct Benefit?		Comments	Benefits
							Storage & Collection of Recyclables	Required			Yes	No		
1							Credit 2.2	Renewable Energy, 10%	1	Encourage and recognize the increasing levels of on-site renewable energy in order to reduce the environmental impacts associated with fossil fuel energy use.	x		As the energy performance of a building is improved with an appropriate design using AMVIC ICF, the total energy use of a building will be reduced. As a result, the incremental costs to achieve a desired Renewable energy percentage will be accounted for as an off-set cost in energy savings.	Owner / Designer
1							Credit 2.3	Renewable Energy, 20%	1	Encourage and recognize the increasing levels of on-site renewable energy in order to reduce the environmental impacts associated with fossil fuel energy use.	x		As the energy performance of a building is improved with an appropriate design using AMVIC ICF, the total energy use of a building will be reduced. As a result, the incremental costs to achieve a desired Renewable energy percentage will be accounted for as an off-set cost in energy savings.	Owner / Designer
							Credit 3	Best Practice Commissioning	1	Verify and ensure that the entire building is designed, constructed, and calibrated to operate as intended.		x		
							Credit 4	Ozone Depletion	1	Reduce the use of HCFC based refrigerants		x		
							Credit 5	Measurement & Verification	1	Provide ongoing accountability and optimization of building energy and water consumption over time.		x		
1							Credit 6	Green Power	1	Encourage the development and use of grid-source, renewable energy technologies on a net zero pollution basis.	x		As the energy performance of a building is improved with an appropriate design using AMVIC ICF, the total energy use of a building will be reduced. As a result, the costs to purchase a Green Power contract will be reduced.	Owner
Materials & Resources														
N							Prereq 1	Storage & Collection of Recyclables	Required	Facilitate the reduction of waste generated by building occupants that is hauled to the landfill.				
1							Credit 1.1	Building Reuse, Maintain 75% of Existing Shell	1	Maintain 75% of existing walls, floors, and roof	x		As appropriately designed AMVIC ICF buildings are re-used, their energy performance benefits can be appreciated. Therefore, they will continue to provide value as well as design opportunity.	Designer / Owner / Contractor
1							Credit 1.2	Building Reuse, Maintain 100% of Shell	1	Maintain 95% of existing walls, floors, and roof	x		As appropriately designed AMVIC ICF buildings are re-used, their energy performance benefits can be appreciated. Therefore, they will continue to provide value as well as design opportunity.	Designer / Owner / Contractor
1							Credit 1.3	Building Reuse, Maintain 100% Shell & 50% Non-Shell	1	Maintain 50% of interior non-structural elements	x		As appropriately designed AMVIC ICF buildings are re-used, their energy performance benefits can be appreciated. Therefore, they will continue to provide value as well as design opportunity.	Designer / Owner / Contractor
1							Credit 2.1	Construction Waste Management, Divert 50%	1	Divert construction, demolition, and land clearing debris from landfill disposal, and return recyclable resources back to the manufacturing process.	x		The EPS constituent of the ICF product is recyclable and may be accepted at some landfills. Moreover, the excess waste is accepted as resale to the manufacturer.	Designer / Contractor
1							Credit 2.2	Construction Waste Management, Divert 75%	1	Divert construction, demolition, and land clearing debris from landfill disposal, and return recyclable resources back to the manufacturing process.	x		The EPS constituent of the ICF product is recyclable and may be accepted at some landfills. Moreover, the excess waste is accepted as resale to the manufacturer.	Designer / Contractor
							Credit 3.1	Resource Reuse, Specify 5%	1	Reuse building materials and products in order to reduce demand for virgin materials and to reduce waste.		x		
							Credit 3.2	Resource Reuse, Specify 10%	1	Reuse building materials and products in order to reduce demand for virgin materials and to reduce waste.		x		
1							Credit 4.1	Recycled Content, Specify 7.5% (post-consumer + ½ post-industrial)	1	Use materials with recycled content such that the sum of post-consumer content plus one-half of the post-industrial content constitutes 7.5% of the total value of materials in the project.	x		The AMVIC ICF block is comprised of 70% recycled materials, of which some is post-consumer polypropylene. Further, Portland cement used during construction can be structurally designed to handle 20% fly-ash content.	Designer / Contractor
1							Credit 4.2	Recycled Content, Specify 15% (post-consumer + ½ post-industrial)	1	Use materials with recycled content such that the sum of post-consumer content plus one-half of the post-industrial content constitutes 15% of the total value of materials in the project.	x		The AMVIC ICF block is comprised of 70% recycled materials, of which some is post-consumer polypropylene. Further, Portland cement used during construction can be structurally designed to handle 20% fly-ash content.	Designer / Contractor
1							Credit 5.1	Regional Materials, 10% Extracted & Manufactured Regionally	1	Use a minimum of 10% of building materials or products for which at least 80% of the mass is extracted, processed and manufactured 500 miles of the project site, or 1500 miles of the project site and shipped by rail or water.	x		With six manufacturing plants distributed across North America and more under development, the regional content of the AMVIC ICF block can meet the intended requirements depending on site location.	Contractor / Owner
							Credit 5.2	Regional Materials, 20% Extracted & Manufactured Regionally	1	Use a minimum of 20% of building materials or products for which at least 80% of the mass is extracted, processed and manufactured 500 miles of the project site, or 1500 miles of the project site and shipped by rail or water.	x		With six manufacturing plants distributed across North America and more under development, the regional content of the AMVIC ICF block can meet the intended requirements depending on site location.	Contractor / Owner
							Credit 6	Rapidly Renewable Materials	1	Replace building materials with rapidly renewable materials.		x		
							Credit 7	Certified Wood	1	Encourage environmentally responsible forest management.	x		The AMVIC ICF system, the need for certified wood-framing materials is reduced. Thus, the incremental costs to use certified wood will be reduced.	Owner
							Credit 8	Durable Building	1	Minimize materials use and construction waste over a building's life resulting from premature failure of the building and its constituent components and assemblies.	x		As a building envelope product, the AMVIC ICF system details several water damage protection strategies (for damp-proofing and water-proofing) that can be practiced on a site-specific basis.	Designer / Contractor



Yes		No		15 Points		Description	Amvic Direct Benefit?		Comments	Benefits
Y	N	Y	N	Yes	No		Yes	No		
6	2	7	7	Indoor Environmental Quality		Prereq 1 Minimum IAQ Performance Required	Establish minimum indoor air quality performance by meeting ASHRAE 62, addendum N.	x	The AMVIC ICF product itself releases zero VOCs and/or air-borne particulates post-construction, and any adhesive and/or caulking product feature leads to an improved IAQ for the occupants. Improved noise attenuation properties are also beneficial.	Owner / Contractor
				Required		Prereq 2 Environmental Tobacco Smoke (ETS) Control	Prevent or minimize the exposure of building occupants to second hand smoke.	x		
				1		Credit 1 Carbon Dioxide (CO₂) Monitoring	Provide capacity for IAQ monitoring to help sustain long-term occupant comfort.	x	When properly installed, the AMVIC ICF will reduce the infiltration levels within a building, which provides the designer with more control to achieve the required airchange effectiveness.	Designer
				1		Credit 2 Ventilation Effectiveness	Provide for the effective delivery and mixing of supply air to support the safety and comfort of building occupants	x		
				1		Credit 3.1 Construction IAQ Management Plan, During Construction	Prevent indoor air quality problems resulting from the construction process in order to help sustain the comfort and well-being of workers and occupants during construction	x	The AMVIC ICF product itself releases zero VOCs and/or air-borne particulates post-construction, and any adhesive and/or caulking product feature leads to an improved IAQ for the occupants.	Owner / Contractor
				1		Credit 3.2 Construction IAQ Management Plan, Before Occupancy	Prevent indoor air quality problems resulting from the construction process in order to help sustain the comfort and well-being of workers and occupants during construction	x		
				1		Credit 4.1 Low-Emitting Materials, Adhesives & Sealants	Reduce the quantity of indoor air contaminants that are odorous, potentially irritating, or harmful to the comfort and well-being of installers and occupants	x	The AMVIC ICF product itself releases zero VOCs, and any adhesive and/or caulking required during construction can be met with low-VOC levels.	Contractor
				1		Credit 4.2 Low-Emitting Materials, Paints	Reduce the quantity of indoor air contaminants that are odorous, potentially irritating, or harmful to the comfort and well-being of installers and occupants	x		
				1		Credit 4.3 Low-Emitting Materials, Carpet	Reduce the quantity of indoor air contaminants that are odorous, potentially irritating, or harmful to the comfort and well-being of installers and occupants	x		
				1		Credit 4.4 Low-Emitting Materials, Composite Wood & Agrifiber	Reduce the quantity of indoor air contaminants that are odorous, potentially irritating, or harmful to the comfort and well-being of installers and occupants	x		
				1		Credit 5 Indoor Chemical & Pollutant Source Control	Minimize exposure of building occupants to potentially hazardous particulates, biological contaminants, and chemical pollutants that adversely impact air and water quality.	x		
				1		Credit 6.1 Controllability of Systems, Perimeter	Provide a high level of controllability of thermal, ventilation, and lighting systems to promote productivity and well-being.	x	As the energy performance of a building is improved with an appropriate design using AMVIC ICF, the thermal frequency will be reduced. As a result, the designer will have more control over ventilation systems, and have more freedom to incorporate operable windows into the resultant occupied areas.	Designer
				1		Credit 6.2 Controllability of Systems, Non-Perimeter	Provide a high level of controllability of thermal, ventilation, and lighting systems to promote productivity and well-being.	x		
				1		Credit 7.1 Thermal Comfort, Comply with ASHRAE 55	Provide a thermally comfortable environment that supports the productivity and well-being of building occupants	x	An AMVIC ICF building offers the opportunity for design features to address thermal radiation, humidity control, and air speed control.	Designer
				1		Credit 7.2 Thermal Comfort, Permanent Monitoring System	Provide a thermally comfortable environment that supports the productivity and well-being of building occupants	x	An AMVIC ICF building offers design features that address thermal radiation, humidity control, and air speed control, therefore, the implementation of a monitoring system is within the designers control.	Designer
				1		Credit 8.1 Daylight & Views, Daylight 75% of Spaces	Provide building occupants with a connection between indoor spaces and the outdoors through daylighting.	x	As the energy performance of a building is improved with an appropriate design using AMVIC ICF, the thermal frequency will be reduced. As a result, the designer will have more control over ventilation systems, which offers freedom to design a window layout such that daylight exposure is improved.	Designer
				1		Credit 8.2 Daylight & Views, Views for 90% of Spaces	Provide building occupants with a connection between indoor spaces and the outdoors through daylighting.	x		
Innovation & Design Process										
Yes		No		5 Points		Description	Amvic Direct Benefit?		Comments	Benefits
Y	N	Y	N	Yes	No		Yes	No		
				1		Credit 1.1 Innovation in Design: Exceptional performance (construction waste management) (5/2)	Divert construction, demolition, and land clearing debris from landfill disposal, and return recyclable resources back to the manufacturing process.	x	The EPS constituent of the ICF product is not accepted at landfills, and is only recyclable. Moreover, the excess waste is accepted as resale to the manufacturer.	Designer / Contractor
				1		Credit 1.2 Innovation in Design: Exceptional performance (energy) (5/2)		x		
				1		Credit 1.3 Innovation in Design: Exceptional performance (water) (5/2)		x		
				1		Credit 1.4 Innovation in Design: Exceptional performance (indoor air quality) (5/2)		x		
				1		Credit 2 LEED™ Accredited Professional		x		
Product Point Contribution										
Yes		No		out of 70 Points		Description	Amvic Direct Benefit?		Comments	Benefits
Y	N	Y	N	Yes	No		Yes	No		
21	7	3	39	Silver 33-38 points Gold 39-51 points Platinum 52-69 points						



Part 9 – ICF FAQs

9.1 Amvic ICF

Q – What are Amvic ICFs?

A – Amvic ICFs are hollow, light-weight "stay in place" forms made of two Expanded Polystyrene (EPS) panels which are connected by polypropylene webs. During construction, the forms are stacked to the desired height then filled with concrete making stable, durable and sustainable walls. They offer a "5 in 1" solution that provides structure, insulation, vapor barrier, sound barrier and attachments for drywall and exterior siding in one easy step which dramatically reduces labour costs and construction time.

Q – What are the advantages of building with Amvic ICF?

A – Amvic ICF structures require 30-50% less energy to heat and cool when used in conjunction with other energy saving products. They are also wind, fire and insect and rodent resistant as well as provide a safe, quiet and comfortable atmosphere for homeowners for many years.

Q – How long will an Amvic ICF structure last?

A – Concrete walls built with Amvic ICFs may last in excess of 100 years with minimal maintenance required to the walls. This is at least 4 times longer than traditional construction.

Q – What ICF sizes are available from Amvic?

A – Amvic comes in 4, 6, 8 & 10 inch (100, 150, 203 and 254mm) concrete cores.

9.2 Why Amvic is Better

Q – Why Amvic is the best on the market?

A – Below are some unique benefits offered by Amvic:

- Strongest form on the market as proven by Canadian Construction Material Center (CCMC) forming capacity strength test in technical guide 03131 at **865 lbs. / sq. ft.**



- Significant reduction in labour costs due to the form's unique design
- Dramatically lowered material wastage
- Web spacing 6 inches on center

In addition, Amvic offers excellent customer service and support through both the corporate office and extensive distributor network across North America.

Q – **Is Amvic ICF easy to use?**

A – Amvic forms are designed to make the construction process as quick and easy as possible in order to reduce labour costs. Forms arrive on site pre-assembled, are fully reversible and require very little taping, gluing and tying during the stacking process.

Q – **What are the physical differences between an Amvic and traditional wall?**

A – An Amvic wall is stronger, more soundproof, more resistant to natural disasters, better insulated, has a superior R-value, is more energy efficient and reduces air infiltration. In addition it also provides numerous benefits from the thermal mass of the concrete.

9.3 Construction

Q – **How tall can you build with the Amvic ICF?**

A – A structural engineer should design multi-storey structures built with Amvic, but the sky is the limit.

Q – **Are there limitations on what kind of structure you can build with Amvic ICF?**

A – No. Virtually any design that can be built conventionally can be built with Amvic ICF.

Q – **Can I construct radius and angled walls using Amvic ICF?**

A – Yes. Amvic offers factory cut radius forms to your custom specifications. Any angle that is required can be made by miter cutting the form at the proper angle and using foam to join the edges.



Q – Can the concrete in Amvic Forms be mechanically vibrated?

A – Yes. Amvic ICFs are one of few forms on the market that are engineered to withstand the internal vibration. In fact, this practice is strongly recommended by Amvic to ensure the proper consolidation of the concrete.

Q – Is a special concrete mix used for Amvic ICF?

A – Generally walls will require 3000 psi (20 MPa) concrete or as specified by the engineer or building code. The maximum aggregate size is 3/4 inch (19mm) placed at a 5-6 inch (125-150mm) slump.

Q – What method should be used to pour the concrete?

A – Concrete can be placed using any one of several methods: concrete pump, conveyer belt, crane and bucket or by a chute directly from the truck. A boom pump is the easiest method, using a 2.5 inch or 3 inch (63.5mm or 75mm) reducer in the hose, to reduce the concrete velocity.

Q – What type of concrete consolidation does Amvic recommend?

A – Amvic strongly recommends internal consolidation with an electric vibrator with a 1 inch (25mm) diameter head.

Q – We would like to build our house ourselves. Can we buy your system and install it?

A – Yes. You can install the Amvic Building System provided you have a good basic knowledge of home construction and have taken the Amvic training seminar. It is highly recommended that you employ a qualified ICF contractor to assist you with the final pre-pour check and concrete placement.

Q – How long do we need to wait after placing the concrete to backfill or put floor and roof systems onto the Amvic ICF Walls?

A – Follow the guidelines set by your structural engineer.



Q – **Where does the moisture from the concrete go once it has been poured into the forms?**

A – Concrete requires water to gain strength through a process called hydration. When ICFs are used, concrete achieves a higher strength because the forms keep the moisture in the mix. Eventually, most of the water is converted to concrete crystals.

9.4 How To

Q – **How are doors and windows installed?**

A – A wooden or vinyl buck is built to the desired rough opening size and installed in the Amvic wall at the desired height during stacking. Once the concrete has cured, the doors and windows are installed as usual into the opening.

Q – **How do you run the electrical and plumbing?**

A – Some utilities must be placed prior to the pour, and others are after the pour. Services access cavities need to be cut before the pour. To do this, use a saw, utility knife or hot knife to cut through the forms, then place the service pipes (or sleeves) in the openings and foam the gaps to prevent concrete leakage during the pour. After the pour, cavities for wiring and plumbing can be cut into the foam using a router, chainsaw, or hot knife. The wiring or plumbing can be placed in these cavities. A drop of foam can be used to hold them in place if necessary.

Q – **How is sheetrock attached?**

A – Sheetrock is attached mechanically with drywall/gypsum screws into the polypropylene webs. Frequently an EPS compatible adhesive such as Foam2Foam is also used in conjunction with the screws.

Q – **How do you hang pictures?**

A – Pictures can typically be hung using a picture hanger with a nail driven anywhere into the sheetrock just like in frame construction. Heavier pictures



should be hung by screws drilled into the embedded webs which can be found every 6 inches (150mm) . The webs can be located using either a magnetic stud finder, or a sensitive electronic stud finder. If you need to hang something between the webs, you can use a molly type anchor into the sheetrock just like for frame construction.

Q – How are grab bars, towel bars, other fixtures installed?

A – Fixtures can be screwed into the webs, or installed using molly bolts through the sheetrock. Alternatively, a backing can be installed between the sheetrock and the block. One method is to use a hot knife to remove 1/2 inch (13mm) of the foam (flush with the webs) and screw in a strip of 1/2 inch (13mm) plywood into the webs wherever possible. After this, fasteners can be screwed into the plywood at any point. A second method is to use Windlock Grapplers™ which are 4 inch x 6 inch (100mm x 150mm) perforated steel plates which are installed into the foam. When sheetrock is applied on top, they become firmly locked in place. After this, fasteners can be screwed into the plywood at any point.

Q – How do you connect internal frame walls to the ICF wall?

A – For regular walls, if the stud lands over a web, screw through the stud with a 3 inch (75mm) deck screw and connect to the web. If it does not span a web, you can use Grapplers (see above) or spring the stud out and use an adhesive to glue the face of the 2X to the foam. In the uncommon case where the frame wall is a shear wall, use anchor bolts or Simpson Strong Ties as if you were installing a ledger and bolt the stud to the concrete.

Q – How are exterior finishes attached?

A – Stucco (acrylic or cementitious) is adhered directly to the foam. Wood, plastic or metal cladding is mechanically fastened to the embedded plastic ties. Stone and brick are attached according to design specifications.



9.5 External Finishes

Q – What does an Amvic structure look like when it is finished?

A – An Amvic structure will look like any conventionally constructed structure when it is finished. A minor difference is that the window sills will be deeper since the walls are thicker.

Q – What kind of siding can be used on the Amvic Building System?

A – Virtually any conventional exterior finish can be used with the Amvic Building System. Proper planning should be considered.

Q – Can we use stucco on the Amvic Forms?

A – Yes. Any type of stucco can be applied directly to the EPS Forms.

9.6 Architectural/Engineering

Q – Does Amvic provide engineering for Amvic walls?

A – Amvic is aligned with a consulting engineering firm which provides structural engineering services to our clients upon their request. This service comes at a fee which depends on the scope of work involved. You can contact Amvic anytime if you wish to have more information on this type of service.

Q – Do you have to use special plans for the Amvic ICF system?

A – No. Conventional house plans can be adapted and used by increasing the exterior wall dimensions to accommodate the thickness of the Amvic walls.



9.7 Cost & Performance

Q – How much does it cost to build with Amvic compared to other building materials?

A – There are many factors that come into play when comparing the cost differences between an Amvic ICF home and a traditionally built home. While the ICF walls themselves may initially cost 1-5% more than 2 x 4 construction and 0-2% more than 2x6 wall construction, cost savings are gained from construction speed, the elimination of studding, vapor barrier, insulation and prepping for an exterior hard coat, reduced waste, and a reduction in the size of heating and air conditioning equipment. Over the long term reduced energy bills and maintenance will also save the owner money.

Q – How does Amvic compare to concrete block or poured wall construction?

A – While the cost of a bare block or poured wall is less, Amvic ICFs provide insulation, furring strips, vapor and air barriers and are ready to finish. This makes them a cost effective and less labour-intensive choice.

Q – What will ICF construction mean for the future value of my home?

A – As energy costs continue to rise, ICF structures can be expected to demand a 10-15% premium over comparable stick-built homes due to their energy efficiency.

Q – What thermal efficiency results will I achieve with Amvic ICF?

A – R-Value is a term given to the property of any material to "resist" the conduction of heat. Amvic ICF alone has an R-Value of 22; however, when the mass and thermal efficiency of the concrete core is taken into account, Amvic ICF can achieve a thermal efficiency equivalent to R-50+ depending on the size of the core.



9.8 Health & Safety

Q – Does Expanded polystyrene (EPS) present a fire hazard?

A – No. Amvic is manufactured with a flame-retardant additive which will not support combustion. Constructed Amvic walls have a 3+ hour fire rating. In addition, tests have shown that in the event of fire, the EPS does not emit any gases any more harmful than those emitted by burning wood.

Q – Will my Amvic ICF home provide any hurricane or tornado protection?

A – With the proper roof configuration, Amvic ICF homes are very resistant to tornados and hurricanes. In most cases, damage is to the external finishing only.

Q – I am concerned about mold and mildew. Will building with Amvic ICF reduce or eliminate this problem?

A – Mold and mildew are not a problem when building with the Amvic system. Mold and mildew can only grow in an environment that provides warmth, moisture and a food source. Since there is no food source in either the EPS or concrete, this significantly reduces any possibility of mold or mildew growth.

Q – Do the Amvic forms "off gas"?

A – No. The Amvic forms are inert and non-toxic having no CFC's, HCFC's or volatile organic chemicals and they do not "off gas". Amvic ICF are manufactured using BASF Styropor. The Greenguard Environmental Institute (GEI) has awarded the Greenguard Indoor Air Quality Certification to BASF Styropor expandable polystyrene foam insulation. For more information, please visit www.greenguard.org.

Q – Do I need to worry about termites?

A – While termites do not feed on EPS like they do wood, they can tunnel through EPS to reach a food source. If termites are problematic in your area, there are several ways of installing Amvic ICF to create termite barriers that should satisfy building inspectors.



Part 10 – Warranty

Amvic Building System Inc.

2 Year Materials Limited Warranty - Canada and United States

Amvic Building System Inc. gives the following manufacturer's warranty to the first owner and any subsequent owner of a structure in which Amvic forms (product) have been used. For the warranty to be valid, the forms must be installed to the specifications of Amvic and purchased in Canada and/or the United States from Amvic and/or Amvic Authorized distributors.

A. Limited Warranty

If the product, or portions thereof, as a result of a manufacturer's abnormality in workmanship or materials (as determined by Amvic): Fails to provide insulation to the R-value level of 22 due to settlement, compression or deterioration as a result of gravity, normal soil pressures or normal climactic conditions, Amvic will reimburse 100% of the purchase price of the product if the claim is made within 2 years from the date of installation of the product.

For the purpose of this warranty the purchase price of the product is the price charged by authorized distributors of Amvic to installing contractors in the territory where the claim is being made exclusive of all other costs, including labor to remove and replace product at the time the claim is accepted by Amvic.

IMPORTANT: FOR THIS WARRANTY TO BE EFFECTIVE, ALL OF THE FOLLOWING CONDITIONS MUST BE SATISFIED, AS REASONABLY DETERMINED BY AMVIC:

- (a) The product must have been purchased from Amvic or an authorized Amvic distributor, for installation in Canada or the United States;
- (b) the first owner of the structure must register this warranty within 90 days of installation by sending the completed Warranty Registration Card to Amvic at the address indicated below;
- (c) this product must be properly installed in accordance with applicable building code standards, and with Amvic installation procedures, by a certified installer (or supervised by a certified installer); and



- (d) Abnormalities in the product must not result from misuse, abuse, improper storage, improper installation or repairs, alteration or modification to the product, including but not limited to abnormalities in the surface coverings, such as waterproof membranes, and or due to unusual physical elements including climatic conditions.

Claims made under this warranty must be made in writing to Amvic at the address below, within the life of the warranty for a particular claim as described above. Amvic shall be permitted a reasonable opportunity to inspect the site with respect to which a claim is made in order to determine if this warranty is applicable.

B. Limitations of Warranty

AMVIC DOES NOT MAKE ANY OTHER WARRANTY OF ANY KIND, WHETHER EXPRESS OR IMPLIED, WITH RESPECT TO THE PRODUCTS.

To the extent allowed by law, the remedies provided by this warranty are the customer's sole and exclusive remedies. No distributor, dealer is authorized to expand or enlarge on this warranty.

C. Limitations of Liability

EXCEPT FOR THE OBLIGATIONS SPECIFICALLY SET FORTH IN THIS WARRANTY, IN NO EVENT SHALL AMVIC BE LIABLE FOR ANY DIRECT, SPECIAL, INCIDENTAL, OR CONSEQUENTIAL DAMAGES, WHETHER BASED ON CONTRACT, TORT, OR ANY OTHER LEGAL THEORY, AND WHETHER ADVISED OF THE POSSIBILITY OF SUCH DAMAGES.



Appendix A

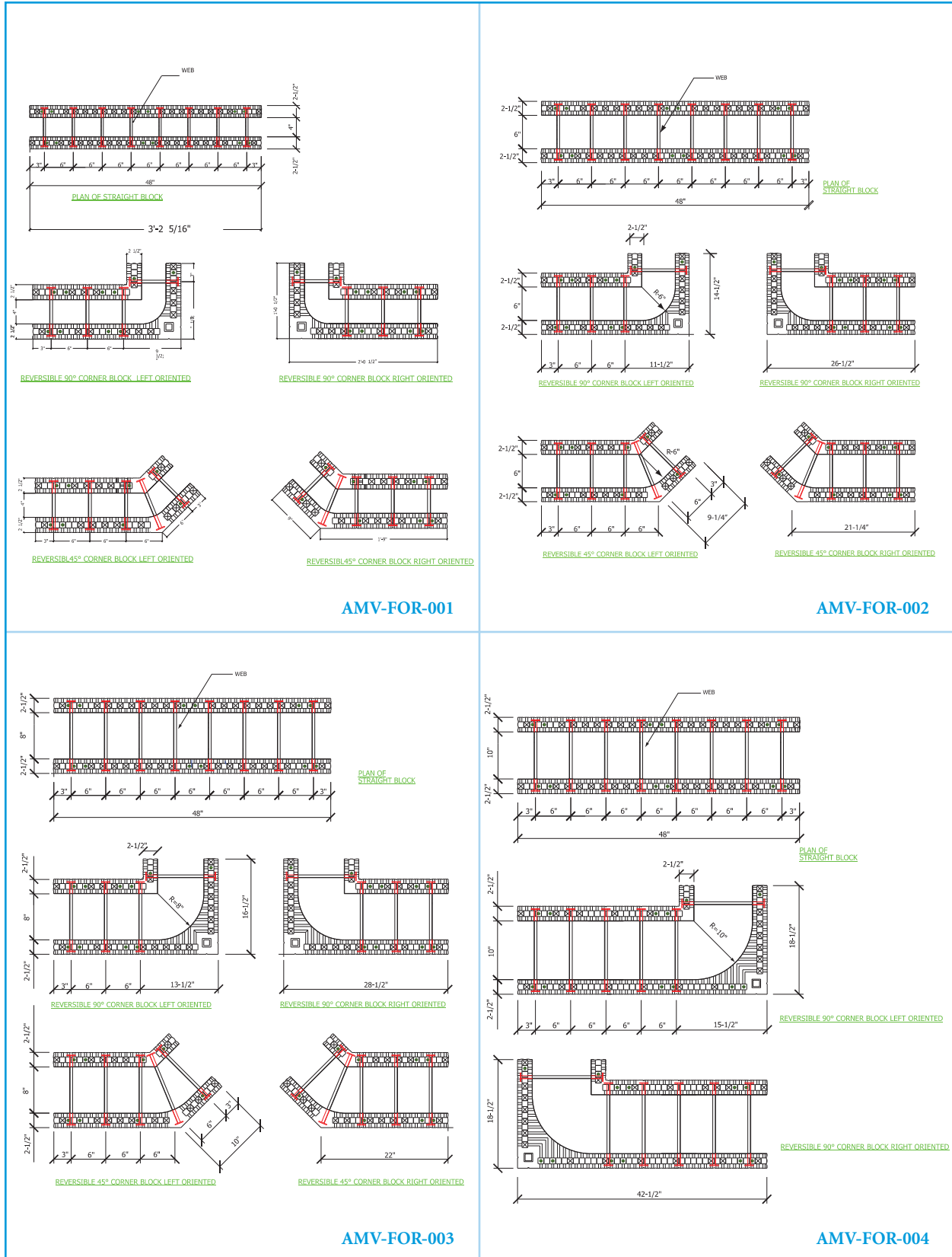

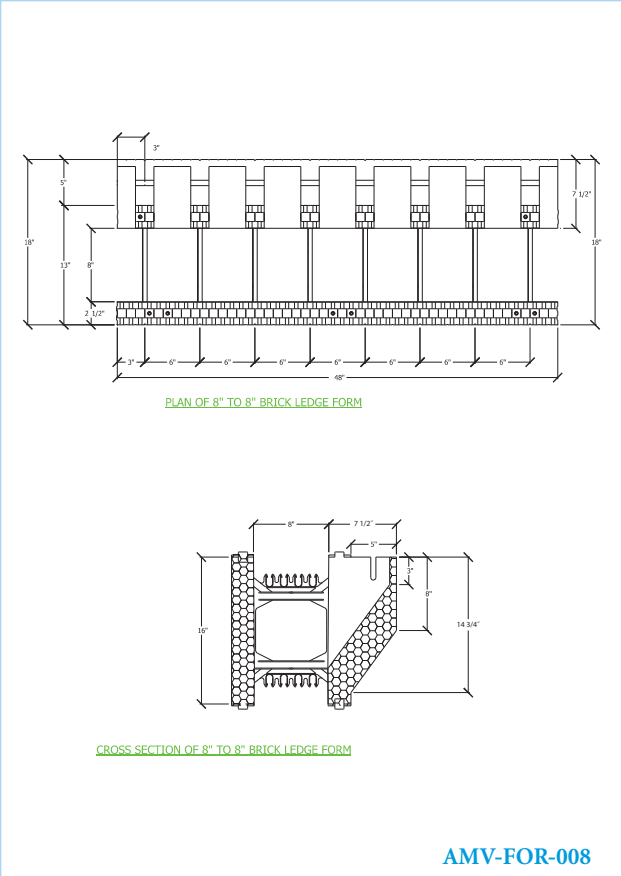
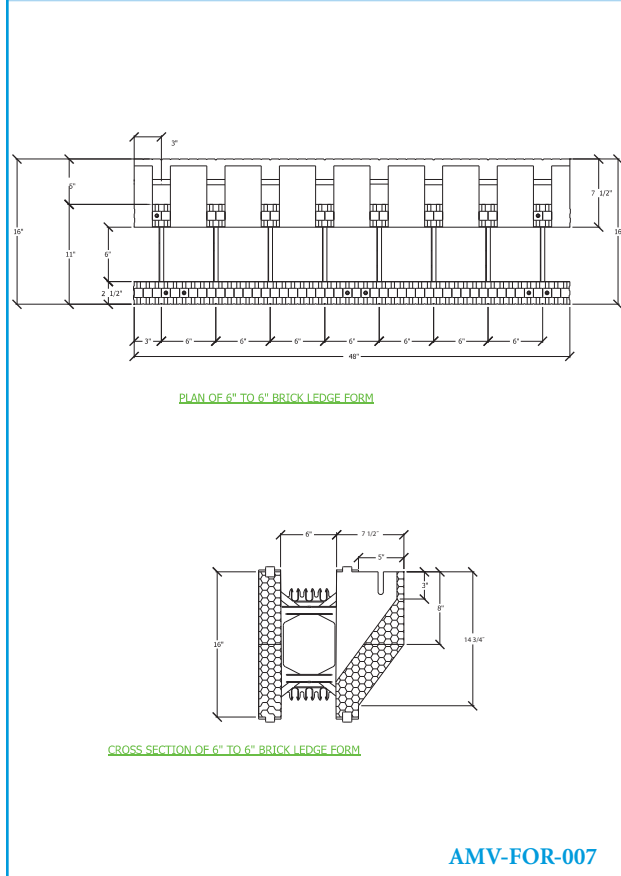
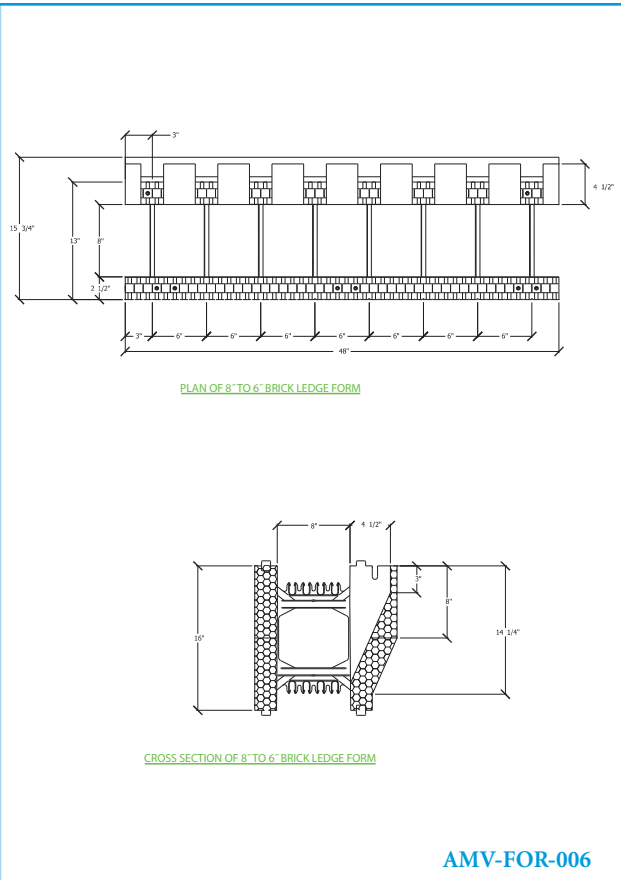
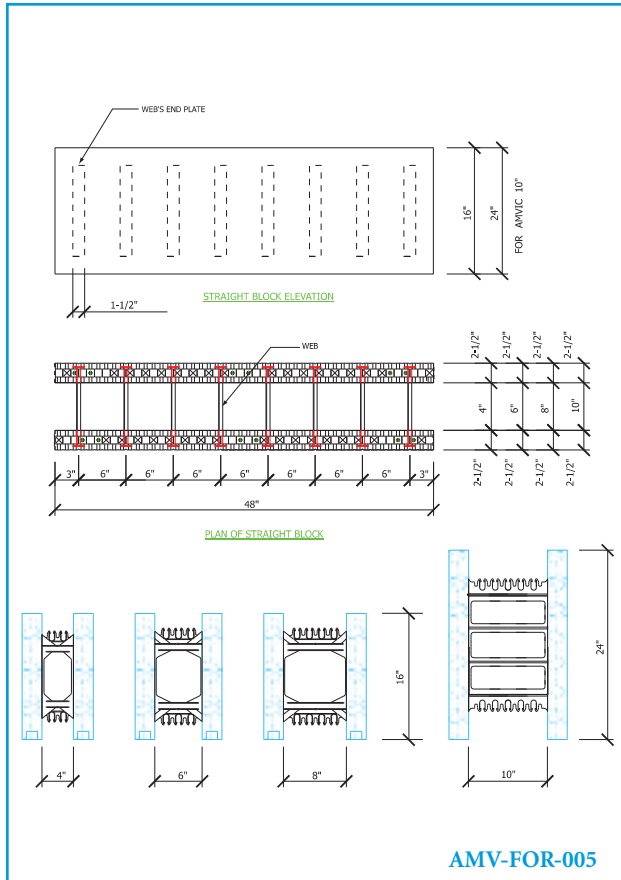

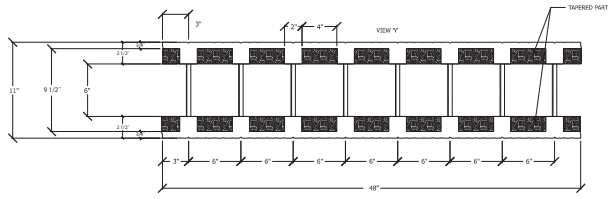

PLAN OF 6" TAPERED TOP FORM

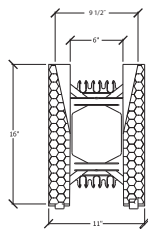

CROSS SECTION OF 6" TAPERED TOP FORM

AMV-FOR-009

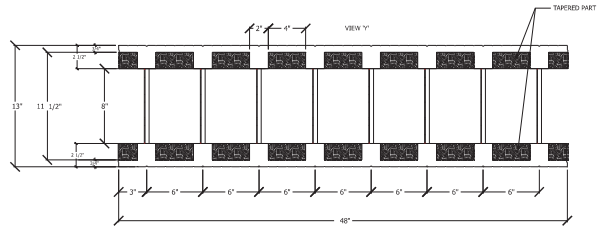

PLAN OF 8" TAPERED TOP FORM

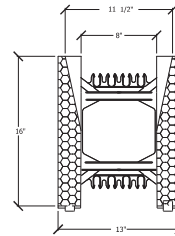

CROSS SECTION OF 8" TAPERED TOP FORM

AMV-FOR-010

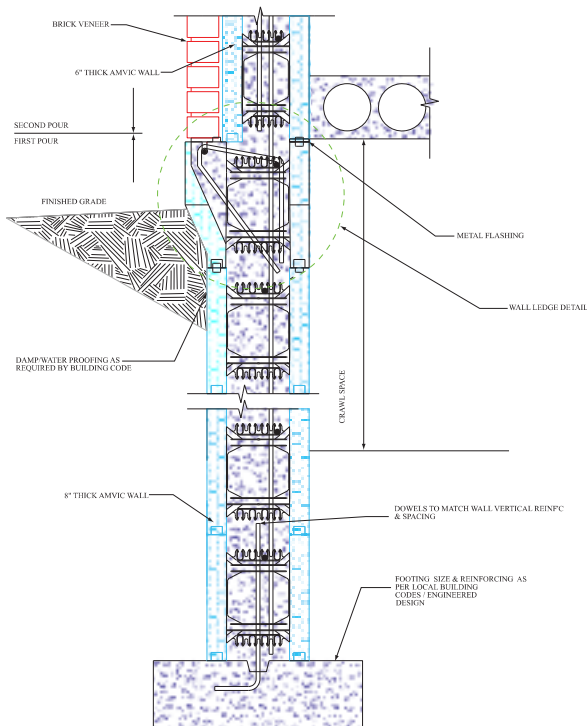

AMV-BRL-001

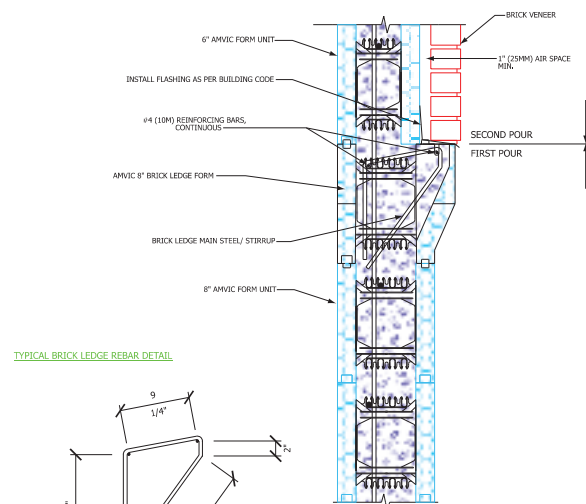

TYPICAL BRICK LEDGE REBAR DETAIL

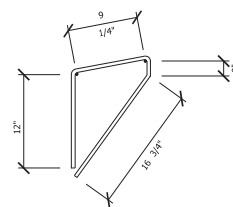

AMV-BRL-002



