

PTP-200™



POLY-THROUGH-PAPER
HEAT SEALER

www.inpaksystems.com

FISCHBEN

PTP-200™

POLY-THROUGH-PAPER HEAT SEALER

Fischbein's Poly-Through-Paper

Heat Sealer: the simple, efficient way to seal poly inner liners in multi-wall paper bags.

Mounted on a rugged, portable pedestal, the PTP-200 is fully adjustable, allowing for various bag sizes, conveyor speeds and heights. To assure a positive seal on flat and gusseted bags, the PTP-200 compresses the bag's inner liner after sealing.

Fischbein's Poly-Through-Paper

Heat Sealer: the ultimate in technology for your bag sealing needs, and only from Fischbein.®

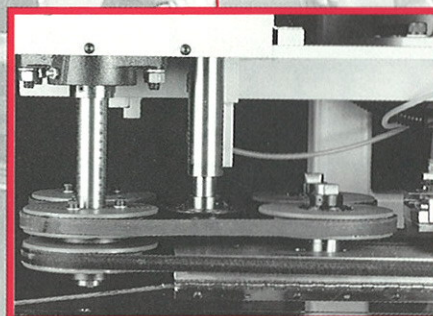
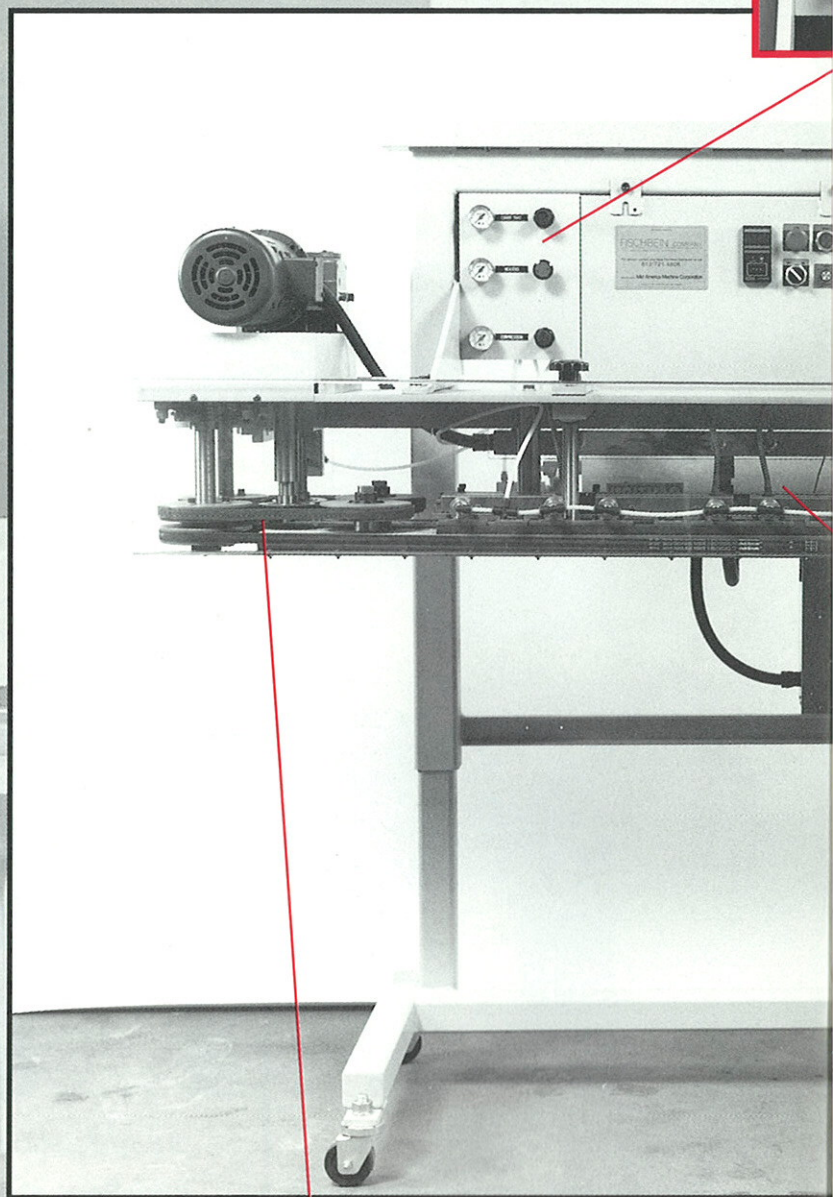

Compression belts ensure positive seal of inner poly-liner.

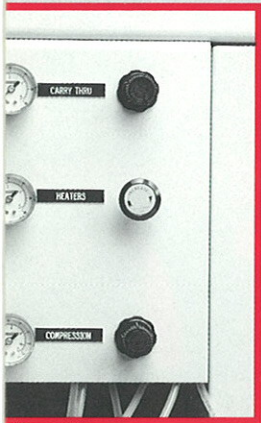

Easy-to-adjust controls for carry thru belt, heater bar pressure and compression belt pressure.

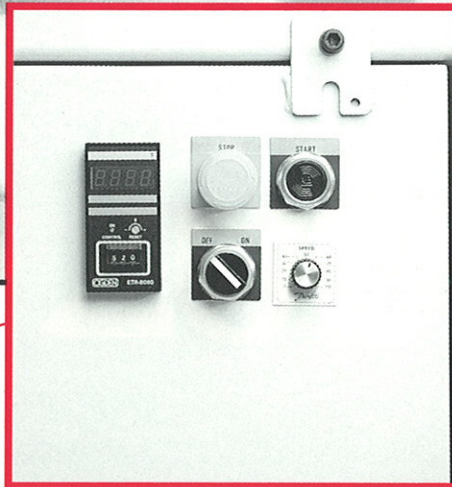

Features on/off switch, digital readout and variable speed control.

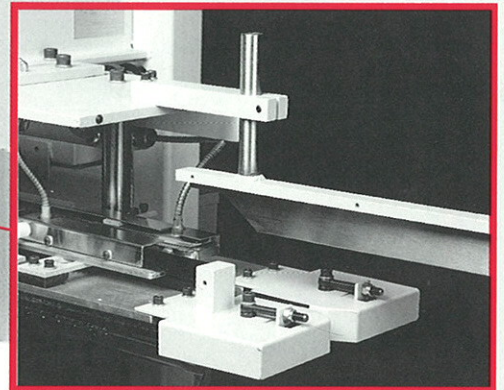

Adjustable height in-feed guide provides consistent location of liner seal.

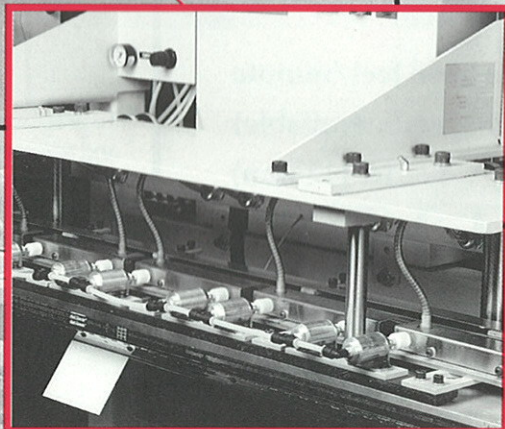

Five separate heater bars follow bag contour, while air cylinders and a precision regulator allow you to apply a precise amount of pressure to bags for maximum heat transfer and optimum seal.

PTP-200

POLY-THROUGH-PAPER HEAT SEALER

Dimensions

Length:	86 in. (2,184 mm)
Width:	27 in. (685 mm)
Height:	57 in. (1,447 mm) minimum 90 in. (2,286 mm) maximum
Weight:	900 lbs. (408 kg)

Electrical

Supply Power:	230 VAC, Single Phase, 50/60Hz
Maximum Current:	25 Amps

Bag Size Range (Empty)

Width:	5 in. - 20 in. (127 mm - 508 mm)
Length:	56 in. (1,422 mm) maximum
Gusset:	Any size including flat bags
Minimum Free Top:	4 in. (101 mm)
Filled Bag Weight:	1 lb. - 110 lbs. (.45 kg - 50 kg)

Pneumatic Supply

Air Source:	80 - 100 PSI, 1 SCFM
-------------	----------------------

Maximum Closing

Rate:	Variable to 60 feet/minute (higher speeds available)
Seal Width:	1/2 in. (12 mm)

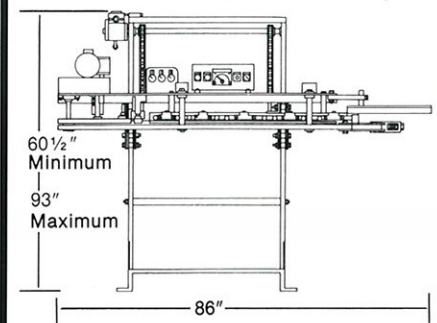
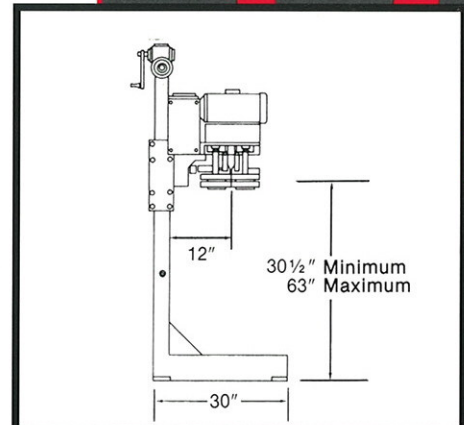

Inner
Poly Liner

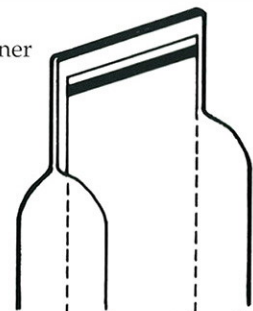

To assure a complete seal on flat and gusseted bags, the PTP-200 compresses bag liners after sealing.



INPAK SYSTEMS INC.
Fillers * Scales * Sewers * Sealers
540A Tasman St., Madison, WI 53714
Phone: 608-221-8180 FAX: 608-221-4473
www.inpaksystems.com