

# 2BE4 Liquid Ring Vacuum Pumps and Compressors

**NASH**  
A Gardner Denver Product

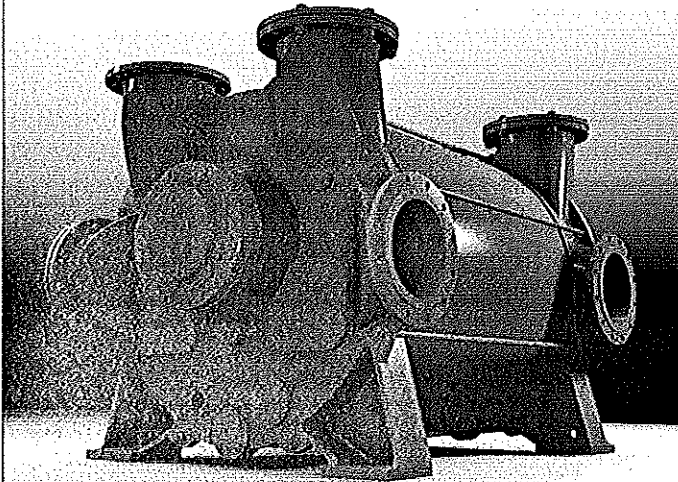

An upgrade of Nash's 2BE3 vacuum pump series, the 2BE4 series offers capacities ranging from 1,500 to 19,000 CFM (2,500 to 33,000 m<sup>3</sup>/hr).

This is achieved by modifications to the shaft bearings and through optimization of the port plates and the impeller. Improvements to internal flow channeling reduce the energy requirements by 6 to 8%.

Optimization of the shaft bearings increases pump flexibility in the event of operational malfunctions and, ensures better lubrication, which extends the service life. An optional connection for rinsing the housing is also available. This feature improves cleaning and the service life.

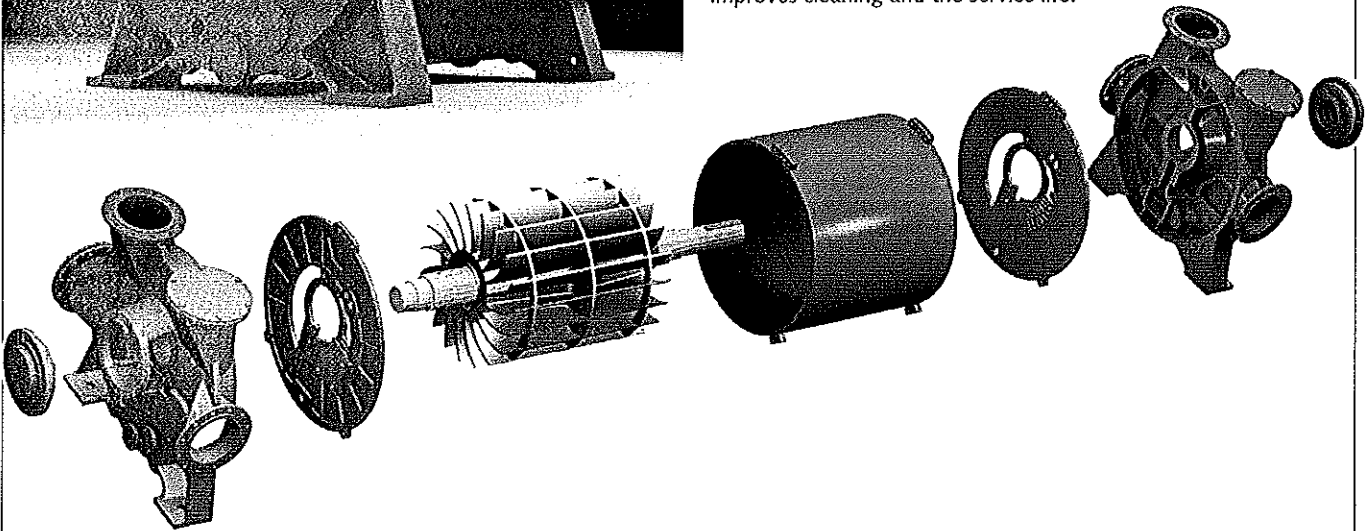

## Basic Specifications

Vacuum Range	to 160 mbar abs./ To 4.7 in Hg abs
Mechanical Seals	Single, double (on request), stuffing box
Differential pressure capability	800 mbar / 11.6 psi
Compressor pressure	> 2bar abs. / 15 psig
Construction material	Ductile iron, stainless steel, combination of both materials

## Performance

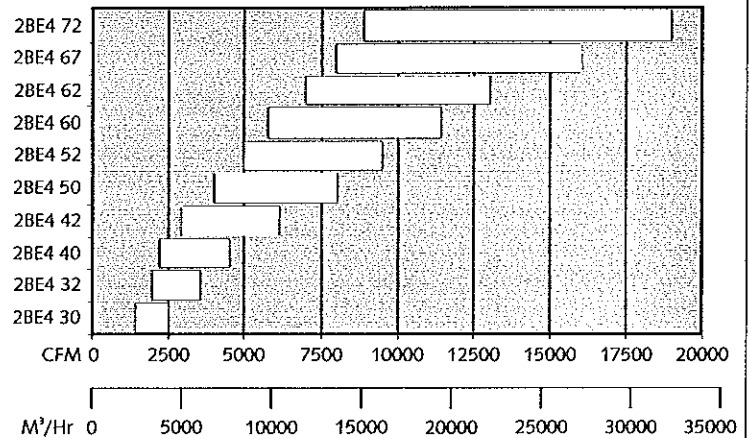

Gardner Denver Nash

9 Trefoil Drive, Trumbull, CT 06611 · phone: +1 800 553 NASH · fax: +1 203 459 3988 · email: nash@gardnerdenver.com  
GDNash.com

# 2BE4

## Liquid Ring Vacuum Pumps and Compressors

Designed to operate in demanding environments like the paper, power, mining and chemical process industries, these pumps offer durability and reliability at a low cost of operation. Each model is equipped with an application-proven polyisoprene-lined body for added corrosion & erosion resistance.

The unique inlet configuration allows for both top and side inlet arrangements to accommodate low headroom installations. In installations where space is limited, the top discharge capability of the 2BE4 allows the use of a top mounted discharge separator that saves floor space and eliminates the need for a trench.

### Dimensions

mm in blue

Pump	A1	A2	B	C	D	E	Inlet	Outlet
2BE4 30	65.4 1661	73.8 1875	38.2 970	35.6 904	18.7 475	4.3 109	6 in. FLG. 150mm FLG.	6 in. FLG. 150mm FLG.
2BE4 32	74.6 1895	83.0 2108	38.2 970	35.6 904	18.7 475	4.3 109	6 in. FLG. 150mm FLG.	6 in. FLG. 150mm FLG.
2BE4 40	82.8 2103	92.9 2360	50.6 1285	45.7 1161	24.4 620	5.1 130	10 in. FLG. 250mm FLG.	10 in. FLG. 250mm FLG.
2BE4 42	94.1 2390	104.3 2649	50.6 1285	45.7 1161	24.4 620	5.1 130	10 in. FLG. 250mm FLG.	10 in. FLG. 250mm FLG.
2BE4 50	102.5 2604	114.7 2913	60.7 1542	57.1 1450	30.5 775	6.3 160	12 in. FLG. 300mm FLG.	12 in. FLG. 300mm FLG.
2BE4 52	112.3 2852	124.5 3162	60.7 1542	57.1 1450	30.5 775	6.3 160	12 in. FLG. 300mm FLG.	12 in. FLG. 300mm FLG.
2BE4 60	111.7 2837	123.8 3144	70.9 1801	67.8 1722	35.4 899	7.1 180	14 in. FLG. 350mm FLG.	14 in. FLG. 350mm FLG.
2BE4 62	123.3 3132	135.4 3439	70.9 1801	67.8 1722	35.4 899	7.1 180	14 in. FLG. 350mm FLG.	14 in. FLG. 350mm FLG.
2BE4 67	133.4 3388	147.6 3749	75.4 1915	73.0 1854	38.4 975	7.9 201	14 in. FLG. 350mm FLG.	14 in. FLG. 350mm FLG.
2BE4 72	141.3 3589	155.3 3945	82.5 2096	78.1 1985	41.8 1062	7.9 201	16 in. FLG. 400mm FLG.	16 in. FLG. 400mm FLG.

All dimensions are approximate

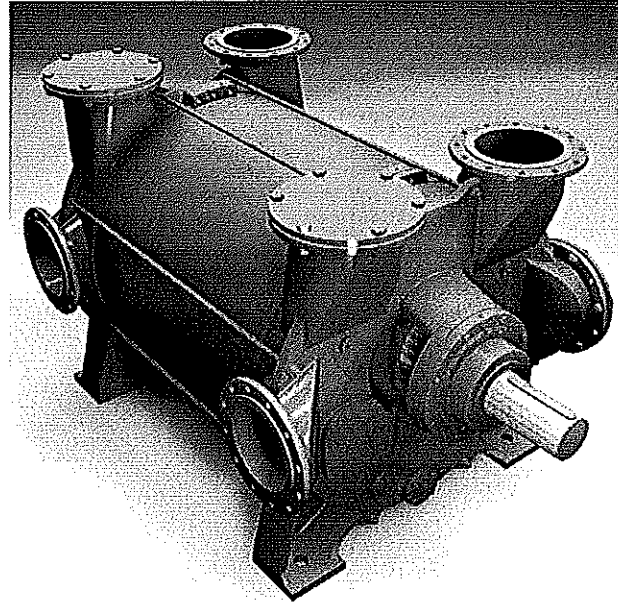

The 2BE4 pumps allow efficient operation over the entire vacuum range without the need to change the pump's internals. When equipped with a center shroud, split vacuum operation up to 12 in. Hg (400 millibar) differential can be achieved. Large inspection ports allow easy access to pump internals for inspection and maintenance.

For more aggressive applications, stainless steel, stainless steel clad and epoxy coated components are available.

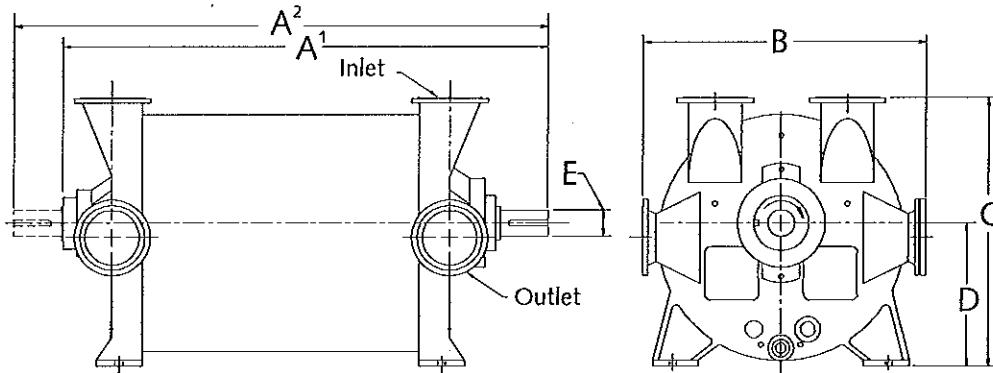

Gardner Denver Nash

9 Trefoil Drive, Trumbull, CT 06611 · phone: +1 800 553 NASH · fax: +1 203 459 3988 · email: nash@gardnerdenver.com  
GDNash.com