

# Rotoclaw II Frozen Meat Breaker

Quiet, rugged, dependable!  
Built for years of trouble-free operation.

## Maintains Product Texture

The RotoClaw II breaks up hard frozen meat blocks without destroying the texture of the product. Its slow-speed rotor produces small pieces without aggravating noise.

## Produce a Variety of Piece Sizes

Piece size can be varied by using different rotors to satisfy most processing requirements.

## Handles Large Frozen Blocks

The RotoClaw II will handle frozen blocks up to 9.5 inches thick and 21 inches wide.

## High Production Rates

Production rates of up to 10,000 lbs. per hour are possible depending on the desired end piece size. For high production, blocks can be stacked one on top of another using the built-in air operated loader.



**REISER**



Leading the food industry in processing and packaging solutions.

# Rotoclaw II Frozen Meat Breaker

Quiet, rugged, dependable!  
Built for years of trouble-free operation.

## Features

- All stainless steel
- Rugged construction
- Compact design
- Complete electrical controls
- Built-in loader
- Quiet operation
- No knives to sharpen
- Quick, easy clean-up
- Low maintenance
- Reliable performance

## Specifications

- Motor:
  - 7-1/2 HP TEFC
  - 220/380 volts, 3 phase, 50 cycles, or
  - 230/460 volts, 3 phase, 60 cycles
- Loader:
  - Built-in
  - Runs on 80 psi air
- Dimensions:
  - 40" wide x 63" long x 106" high  
(1,016 mm wide x 1,600 mm long  
x 2,692 mm high)
- Weight:
  - 1,350 lbs. (612 kg)

Stainless steel  
claws on slow  
turning  
rotor break  
up blocks quietly.

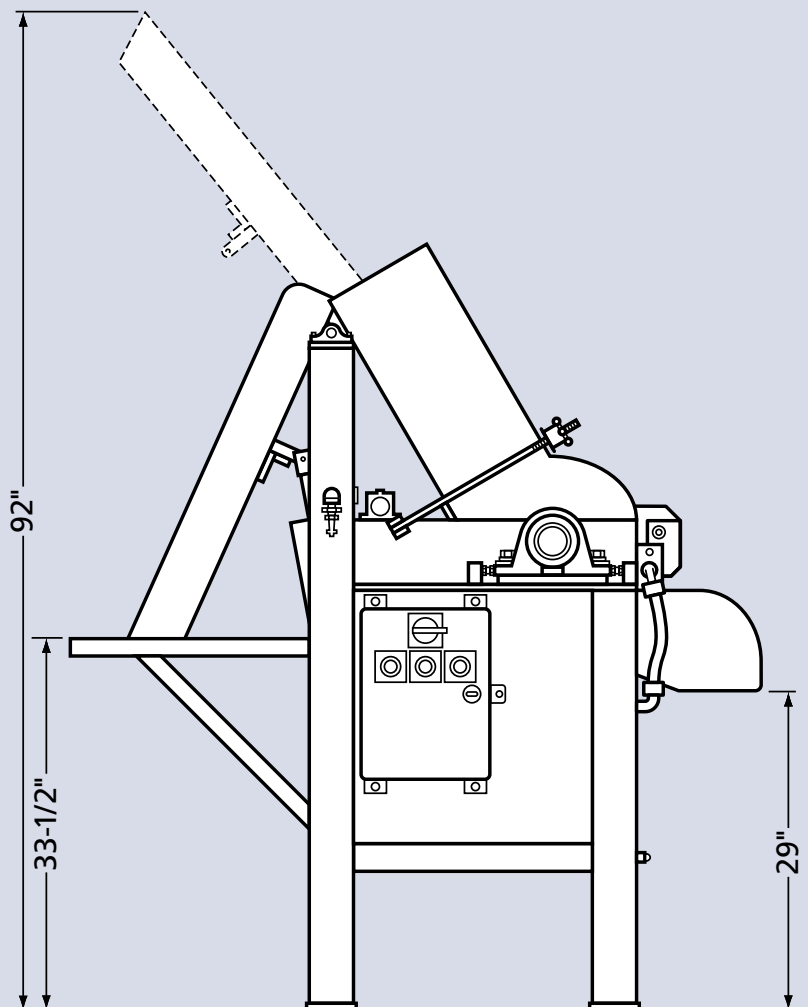
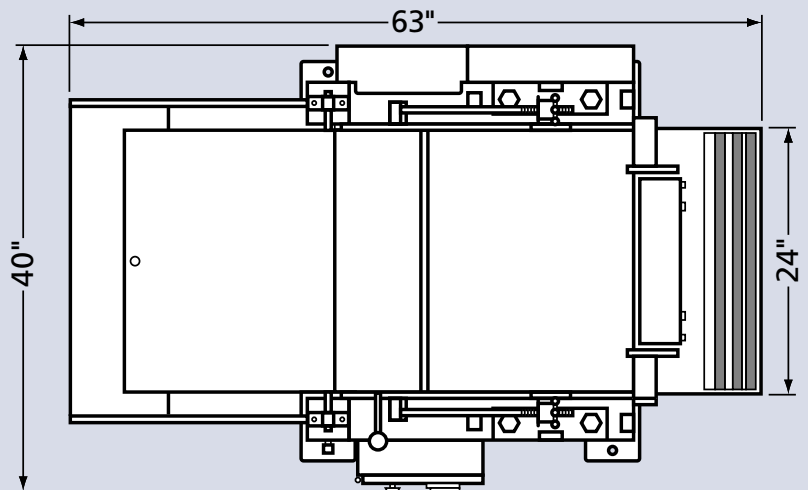
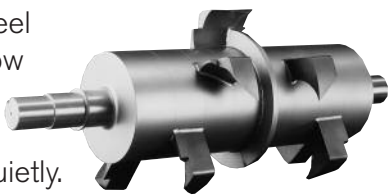

**Reiser**  
725 Dedham Street  
Canton, MA 02021  
Telephone (781) 821-1290  
Fax (781) 821-1316

**Reiser Canada**  
1549 Yorkton Court, Unit #4  
Burlington, ON L7P 5B7  
Telephone (905) 631-6611  
Fax (905) 631-6607

**Reiser UK**  
Maidstone Road  
Kingston, Milton Keynes MK10 0BD  
Telephone (01908) 585300  
Fax (01908) 585400

Visit us at [www.reiser.com](http://www.reiser.com)



# REISER



Leading the food industry in processing and packaging solutions.